



# INSTALLATION AND OPERATION MANUAL

**Haliburton™**  
(GDS28-1 illustrated)

**SAFETY INFORMATION**

**! WARNING**

**FIRE OR EXPLOSION HAZARD**

Failure to follow safety warnings exactly could result in serious injury, death, or property damage.

- Do not store or use gasoline or other flammable vapors and liquids in the vicinity of this or any other appliance.

**- WHAT TO DO IF YOU SMELL GAS:**

- Do not try to light any appliance.
- Do not touch any electrical switch; do not use any phone in your building.
- Immediately call your gas supplier from a neighbour's phone. Follow the gas supplier's instructions.
- If you cannot reach your gas supplier, call the fire department.

**- Installation and service must be performed by a qualified installer, service agency, or the supplier.**

This appliance may be installed in an aftermarket, permanently located, manufactured home (USA only) or mobile home, where not prohibited by local codes.

This appliance is only for use with the type of gas indicated on the rating plate. This appliance is not convertible for use with other gases, unless a certified kit is used.

**INSTALLER:**

Leave this manual with the appliance

**CONSUMER:**

Retain this manual for future reference

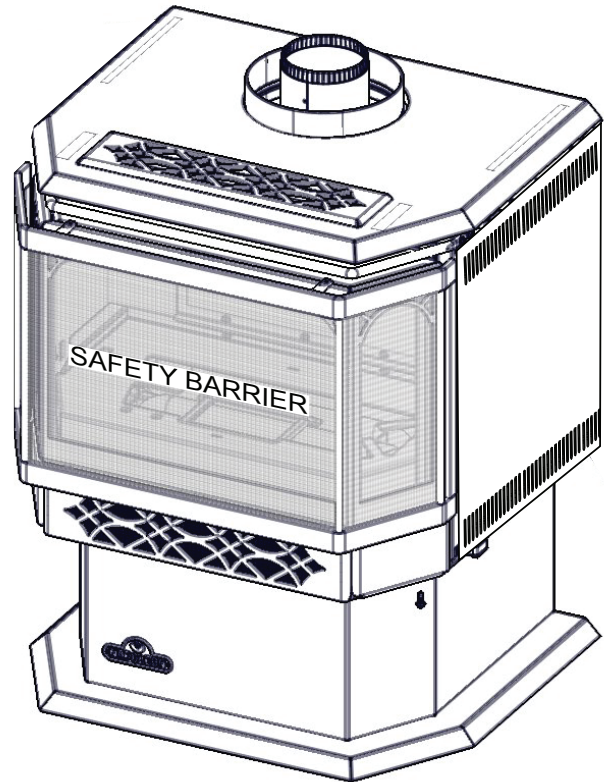

Model GS28 is made up of Model GDS28 and Natural Vent Adapter Kit GS-150KT

**FOR INDOOR USE ONLY**

**CERTIFIED TO THE CANADIAN AND AMERICAN NATIONAL STANDARDS:  
CSA 2.22 AND ANSI Z21.50 FOR VENTED DECORATIVE GAS APPLIANCES**

APPLY SERIAL NUMBER LABEL FROM CARTON



Wolf Steel Ltd., 24 Napoleon Rd., Barrie, ON, L4M 0G8 Canada / 103 Miller Drive, Crittenden, Kentucky, USA, 41030  
Phone 1 (866) 820-8686 • www.napoleon.com • hearth@napoleon.com

## ! WARNING

- **This appliance is hot when operated and can cause severe burns if contacted.**
- **Any changes or alterations to this appliance or its controls can be dangerous and is prohibited.**
- Do not operate appliance before reading and understanding operating instructions. Failure to operate appliance according to operating instructions could cause fire or injury.
- Ensure the glass door is opened or removed when lighting the pilot for the first time and when the gas supply has run out.
- Risk of fire or asphyxiation, do not operate appliance with fixed glass removed and never obstruct the front opening of the appliance.
- Do not connect 110 volts to the control valve, with the exception of models; GSST8 and GT8.
- Risk of burns. The appliance should be turned off and cooled before servicing.
- Do not install damaged, incomplete or substitute components.
- Risk of cuts and abrasions. Wear protective gloves, protective footwear, and safety glasses during installation. Sheet metal edges may be sharp.
- Do not burn wood or other materials in this appliance.
- Provide adequate ventilation and combustion air. Provide adequate accessibility clearance for servicing and operating the appliance.
- High pressure will damage valve. Disconnect gas supply piping before pressure testing gas line at test pressures above 1/2 psig. Close the manual shut-off valve before pressure testing gas line at test pressures equal to or less than 1/2 psig (35mb).
- The appliance must not be operated at temperatures below freezing (32°F / 0°C). Allow the appliance to warm to above freezing prior to operation, with the exception of models; GSS36, GSS42; these appliances are suitable for 0°F / -18°C.
- **Children and adults should be alerted to hazards of high surface temperature and should stay away to avoid burns or clothing ignition.**
- **Young children should be carefully supervised when they are in the same room as the appliance. Toddlers, young children and others may be susceptible to accidental contact burns. A physical barrier is recommended if there are at risk individuals in the house. To restrict access to an appliance or stove, install an adjustable safety gate to keep toddlers, young children and other at risk individuals out of the room and away from hot surfaces.**
- **Clothing or other flammable material should not be placed on or near the appliance.**
- **Due to high temperatures, the appliance should be located out of traffic and away from furniture and draperies.**
- Furniture or other objects must be kept a minimum of 4 feet (1.22m) away from the front of the appliance.
- Ensure you have incorporated adequate safety measure to protect infants/toddlers from touching hot surfaces.
- Even after the appliance is off, it will remain hot for an extended period of time.
- Check with your local hearth specialty dealer for safety screens and hearth guards to protect children from hot surfaces. These screens and guards must be fastened to the floor.
- **Any safety screen, guard or barrier removed for servicing the appliance, must be replaced prior to operating the appliance.**
- It is imperative that the control compartments, burners and circulating blower and its passageway in the appliance and venting system are kept clean. The appliance and its venting system should be inspected before use and at least annually by a qualified service person. More frequent cleaning may be required due to excessive lint from carpeting, bedding material, etc. The appliance area must be kept clear and free from combustible materials, gasoline and other flammable vapors and liquids.
- If the appliance shuts off, do not re-light until you provide fresh air. If appliance keeps shutting off, have it serviced. Keep burner and control compartment clean.
- Under no circumstances should this appliance be modified.
- Do not allow wind or fans to blow directly into the appliance. Avoid any drafts that alter burner flame patterns.

# DANGER

**HOT GLASS WILL CAUSE BURNS.**

**DO NOT TOUCH GLASS UNTIL COOLED.**



**NEVER ALLOW CHILDREN TO TOUCH GLASS.**

A barrier designed to reduce the risk of burns from the hot viewing glass is provided with this appliance and must be installed for the protection of children and other at-risk individuals.

## WARNING

- Do not use a blower insert, heat exchanger insert or other accessory not approved for use with this appliance.
- This appliance must not be connected to a chimney flue pipe serving a separate solid fuel burning appliance.
- Do not use this appliance if any part has been under water. Immediately call a qualified service technician to inspect the appliance and to replace any part of the control system and any gas control which has been under water.
- Do not operate the appliance with the glass door removed, cracked or broken. Replacement of the glass should be done by a licensed or qualified service person, if equipped.
- Do not strike or slam shut the appliance glass door, if equipped.
- **Only doors / optional fronts certified with the appliance are to be installed on the appliance.**
- Keep the packaging material out of reach of children and dispose of the material in a safe manner. As with all plastic bags, these are not toys and should be kept away from children and infants.
- Carbon or soot should not occur in a vent free appliance as it can distribute into the living area of your home. If you notice any signs of carbon or soot, immediately turn off your appliance and arrange to have it serviced by a qualified technician before operating it again.
- If equipped, the screen must be in place (closed) when the appliance is in operation.
- When equipped with pressure relief doors, they must be kept closed while the appliance is operating to prevent exhaust fumes containing carbon monoxide, from entering into the home. Temperatures of the exhaust escaping through these openings can also cause the surrounding combustible materials to overheat and catch fire.
- Carbon monoxide poisoning may lead to death; early signs of carbon monoxide poisoning resemble the flu, with headache, dizziness and/or nausea. If you have these signs, the appliance may not be working properly. Get fresh air at once! Have appliance serviced. Some people; pregnant women, persons with heart or lung disease, anemia, those under the influence of alcohol, those at high altitudes are more affected by carbon monoxide than others. Failure to keep the primary air opening(s) of the burner(s) clean may result in sooting and property damage.
- As with any combustion appliance, we recommend having your appliance regularly inspected and serviced as well as having a Carbon Monoxide Detector installed in the same area to defend you and your family against Carbon Monoxide (not applicable for outdoor appliances).
- Ensure clearances to combustibles are maintained when building a mantel or shelves above the appliance. Elevated temperatures on the wall or in the air above the appliance can cause melting, discolouration or damage to decorations, a TV or other electronic components.
- **For appliances equipped with a safety barrier; if the barrier becomes damaged, the barrier shall be replaced with the manufacturer's barrier for this appliance.**
- **Installation and repair should be done by a qualified service person. It is imperative that control compartments, burners and circulating air passageways of the appliance be kept clean.**
- For outdoor products only: this appliance must not be installed indoors or within any structure that prevents or inhibits the exhaust gases from dissipating in the outside atmosphere.
- If applicable, the millivolt version of this appliance uses and requires a fast acting thermocouple. Replace only with a fast acting thermocouple supplied by Wolf Steel Ltd.

 **WARNING:** This product can expose you to chemicals including lead and lead compounds, which are known to the State of California to cause cancer, and chemicals including carbon monoxide, which are known to the State of California to cause birth defects or other reproductive harm. For more information, go to [www.P65Warnings.ca.gov](http://www.P65Warnings.ca.gov).

 **WARNING** 

**FIRE RISK HAZARD / DELAYED IGNITION**

**High supply pressure will damage the valve / controls.**



Disconnect the appliance main gas valve/control from the supply piping when pressure testing that system at pressures in excess of 1/2 psi (3.5 kPa).

Isolate the appliance with it's shut off valve during any pressure testing of the supply piping at pressures equal to or less than 1/2 psi (3.5 kPa).



# table of contents

<b>general information</b>	<b>5</b>	<b>finishing</b>	<b>27</b>
rates and efficiencies	5	safety screen installation and removal	27
general instructions	6	door closing and opening	28
rating plate information	7	log placement	29
mobile home installation (model GDS28)	7	glowing embers	30
dimensions	8	charcoal embers	30
<b>venting</b>	<b>9</b>	logo placement	30
typical vent installation	10	control access cover removal / installation	30
special vent installations	11	<b>operating instructions</b>	<b>31</b>
periscope termination	11	operating/lighting instructions	31
vent terminal clearances	12	<b>wiring diagram (electronic)</b>	<b>32</b>
vent flow charts	13	<b>operation (electronic)</b>	<b>33</b>
definitions	13	pilot-on-demand	34
elbow vent lengths	13	<b>operation (millivolt)</b>	<b>35</b>
horizontal termination	14	<b>adjustment</b>	<b>36</b>
top exit vertical termination	16	pilot burner adjustment	36
vertical through existing chimney	18	venturi adjustment	37
<b>installation</b>	<b>19</b>	flame characteristics	37
minimum clearances to combustibles	19	<b>maintenance</b>	<b>38</b>
horizontal installation	20	annual maintenance	39
vertical installation	21	care of glass	39
horizontal air terminal installation - model GDS28	21	blower replacement	40
vertical air terminal installation	22	<b>replacement parts</b>	<b>41</b>
appliance vent connection	23	overview	42
natural vent specifics	23	millivolt valve train assembly	43
chimney installation	23	electronic valve train assembly	44
combustion air	23	<b>accessories</b>	<b>45</b>
installing natural vent	24	<b>troubleshooting (millivolt)</b>	<b>46</b>
natural vent	24	<b>troubleshooting (electronic)</b>	<b>49</b>
adding vent sections	25	<b>warranty</b>	<b>52</b>
<b>gas installation</b>	<b>26</b>	<b>service history</b>	<b>53</b>
<b>optional wall switch / remote (millivolt)</b>	<b>26</b>		

## note:

The information throughout this manual is believed to be correct at the time of printing. Wolf Steel Ltd. reserves the right to change or modify any information within this manual at any time without notice. Changes, other than editorial, are denoted by a vertical line in the margin.

**Installer, please fill out the following information:**

Customer: \_\_\_\_\_  
 Address: \_\_\_\_\_  
 Date of Installation: \_\_\_\_\_  
 Location of Appliance: \_\_\_\_\_  
 Installer: \_\_\_\_\_  
 Dealer/Distributor \_\_\_\_\_  
 Contact Number: \_\_\_\_\_  
 Serial #: \_\_\_\_\_

Model: \_\_\_\_\_

- Natural Gas:**  GDS28-1NSB  
 GS28-1N  
 GDS28-1NE  
 GS28-1NE

- Propane:**  GDS28-1PSB  
 GS28-1P  
 GDS28-1PE  
 GS28-1PE

## 1.0 general information

When the appliance is installed at elevations above 4,500 ft (1372m), and in the absence of specific recommendations from the local authority having jurisdiction, the certified high altitude input rating shall be reduced at the rate of 4% for each additional 1,000 ft (305m).

Change in flame appearance from "HI" to "LO" is more evident in natural gas than in propane. Expansion / contraction noises during heating up and cooling down cycles are normal and to be expected.

This appliance may be installed in an aftermarket permanently located, manufactured mobile home, where not prohibited by local codes.

**This appliance is only for use with the type of gas indicated on the rating plate. This appliance is not convertible for use with other gases, unless a certified kit is used.**

**note:**

A barrier designed to reduce the risk of burns from the hot viewing glass is provided with the appliance and must be installed.

This appliance is approved for bedroom and bed-sitting room installations.

The protective wrap on plated parts is best removed when the assembly is at room temperature but this can be improved if the assembly is warmed, using a hair dryer or similar heat source. The protective wrap must be removed before operating the appliance.

**Vented decorative gas appliance: not a source of heat; not for use with solid fuel.**

### 1.1 rates and efficiencies

	GDS28		GS28	
	NG	P	NG	P
Altitude (FT)	0-4,500		0-4500	
Max. Input (BTU/HR)	30,000	26,000	30,000	26,000
Max. Output (BTU/HR)	25,500	22,360	24,600	21,600
Min. Inlet Gas Supply Pressure	4.5" (11mb) Water Column	11" (27mb) Water Column	4.5" (11mb) Water Column	11" (27mb) Water Column
Max. Inlet Gas Supply Pressure	7" (17mb) * Water Column	13" (32mb) Water Column	7" (17mb) * Water Column	13" (32mb) Water Column
Manifold Pressure (Under Flow Conditions)	3.5" (9mb) Water Column	10" (25mb) Water Column	3.5" (9mb) Water Column	10" (25mb) Water Column

\* Max. inlet pressure not to exceed 13".

# general information

## 1.2 general instructions

### WARNING

- Always light the pilot, whether for the first time or if the gas supply has run out, with the glass door opened or removed.
- Provide adequate clearance for servicing and operating the appliance.
- Provide adequate ventilation.
- Never obstruct the front opening of the appliance.
- Objects placed in front of the appliance must be kept a minimum of 48" (121.9cm) from the front face of the appliance.
- Surfaces around and especially above the appliance can become hot. Avoid contact when the appliance is operating.
- Fire risk. Explosion hazard.
- High pressure will damage valve. Disconnect gas supply piping before pressure testing gas line at test pressures above 1/2 PSIG. Close the manual shut-off valve before pressure testing gas line at test pressures equal to or less than 1/2 PSIG (35mb).
- Use only Wolf Stetel-approved optional accessories and replacement parts with this appliance. Using non-listed accessories (blowers, doors, louvres, trims, gas components, venting components, etc.) could result in a safety hazard and will void the warranty and certification.
- The appliance must not be operated at temperatures below freezing (32°F / -°C). Allow the appliance to warm to above freezing prior to operation.
- This appliance has been designed and certified for indoor use only.

**THIS GAS APPLIANCE MUST BE INSTALLED AND SERVICED BY A QUALIFIED INSTALLER** to conform with local codes. Installation practices vary from region to region and it is important to know the specifics that apply to your area, for example in the state of Massachusetts:

- This product must be installed by a licensed plumber or gas fitter when installed within the commonwealth of Massachusetts.
- The appliance damper must be removed or welded in the open position prior to installation of an appliance insert or gas log.
- The appliance off valve must be a "T" handle gas cock.
- The flexible connector must not be longer than 36 inches (0.9m).
- A carbon monoxide detector is required in all rooms containing gas fired appliances.
- The appliance is not approved for installation in a bedroom or bathroom unless the unit is a direct vent sealed combustion product.

The installation must conform with local codes or, in absence of local codes, the National Gas and Propane Installation Code CSA B149.1 in Canada, or the National Fuel Gas Code, ANSI Z223.1 / NFPA 54 in the United States. Suitable for mobile home installation if installed in accordance with the current standard CAN/CSA Z240MH Series, for gas equipped mobile homes, in Canada or ANSI Z223.1 and NFPA 54 in the United States.

The appliance and its individual shutoff valve must be disconnected from the gas supply piping system during any pressure testing of that system at test pressures in excess of 1/2 psig (35 mb).

The appliance must be isolated from the gas supply piping system by closing its individual manual shutoff valve during any pressure testing of the gas supply piping system at test pressures equal to or less than 1/2 psig (35 mb). When installed with a blower or fan, the junction box must be electrically connected and grounded in accordance with local codes. In the absence of local codes, use the current CSA C22.1 Canadian Electrical Code in Canada or the ANSI / NFPA 70 National Electric Code in the United States. In the case where the blower is equipped with a power cord, it must be connected into a properly grounded receptacle. The grounding prong must not be removed from the cord plug.

The following does not apply to inserts; as long as the required clearance to combustibles is maintained, the most desirable and beneficial location for an appliance is in the center of a building, thereby allowing the most efficient use of the heat created. The location of windows, doors and, the traffic flow in the room where the appliance is to be located should be considered. If possible, you should choose a location where the vent will pass through the house without cutting a floor or roof joist. If the appliance is installed directly on carpeting, vinyl tile or other combustible material other than wood flooring, the appliance shall be installed on a metal or wood panel extending the full width and depth, unless otherwise tested.



We suggest that our gas hearth products be installed and serviced by professionals who are certified in the U.S. by the National Fireplace Institute® (NFI) as NFI Gas Specialists

### 1.3 rating plate information

Certified to Canadian and American National Standards: **CSA 2.22-XXXX / ANSI Z21.50-XXXX for Vented Decorative Gas Appliances**  
 Certifié selon les normes Nationales Canadiennes et Américaines: **CSA 2.22-XXXX / ANSI Z21.50-XXXX pour les Appareils à gaz décoratif à évacuation**

Direct vent, vented gas fireplaces. Approved for bedroom, bathroom and bed-sitting room installation. Suitable for mobile home installation, if installed in accordance with the current standard CAN / CSA Z240MH Series gas equipped mobile homes in Canada, or, in the United States, the *Manufactured Home Construction and Safety Standard, Title 24 CFR, Part 3280*. When this US Standard is not applicable, use the *Standard for Fire Safety Criteria for Manufactured Home Installations, Sites and Communities, ANSI / NFPA 501A*. This appliance must be installed in accordance with local codes, if any; if none, follow the current ANSI Z223.1 or CSA B149. **For use with barrier WXXX-XXXX. Follow installation instructions.**  
 Foyer à gaz ventilé. Homologué pour installation dans une chambre à coucher, une salle de bain et un studio. Approuvé pour installation dans une maison mobile si son installation conforme aux exigences de la norme CAN / CSA Z240MH Série de maisons mobile équipées au gaz en vigueur au Canada, ou, aux États-Unis selon la norme 24 CFR, Part 3280. *Manufactured Home Construction and Safety Standard*. Dans le cas où cette norme d'États-Unis n'est pas pertinentes, utiliser la norme NFPA 501A, *Fire Safety Criteria for Manufactured Home Installations, Sites and Communities*. Installer l'appareil selon les codes ou règlements locaux ou, en l'absence de tels règlements, selon les codes d'installation ANSI Z223.1 ou CSA B149 en vigueur. **Utiliser uniquement avec l'écran WXXX-XXXX. Suivre les instructions d'installation.**

**SP**  
C US  
Energy Verified  
Energie vérifiée  
REFERENCE# 161746

**VENTED DECORATIVE GAS APPLIANCE: NOT A SOURCE OF HEAT, NOT INTENDED FOR USE AS A HEATING APPLIANCE, NOT FOR USE WITH SOLID FUEL.**  
**APPAREIL À GAZ DÉCORATIF À ÉVACUATION: N'EST PAS UNE SOURCE DE CHALEUR; N'EST PAS DESTINÉ À ÊTRE UTILISÉ COMME UN APPAREIL DE CHAUFFAGE; NE CONVIENT PAS AUX COMBUSTIBLES SOLIDES.**

**FOR USE WITH GLASS DOORS CERTIFIED WITH THIS APPLIANCE ONLY. POUR UTILISATION UNIQUEMENT AVEC LES PORTES EN VERRE CERTIFIÉES AVEC L'APPAREIL.**

For natural gas when equipped with No. XX drill size orifice.  
 For propane when equipped with No. XX drill size orifice.  
 Convient au gaz naturel quand l'appareil est muni d'un injecteur de diamètre no. XX.  
 Convient au propane quand l'appareil est muni d'un injecteur de diamètre no. XX.

**WARNING:** Do not add any material to the appliance which will come in contact with the flames, other than that supplied by the manufacturer with the appliance.  
**AVERTISSEMENT:** N'ajoutez pas à cet appareil aucun matériau devant entretenir contact avec les flammes autre que celui qui est fourni avec cet appareil par le fabricant.  
 The appliance must be vented using the appropriate Napoleon vent kits. See installation manual for venting specifications. Proper reinstallation and resealing is necessary after servicing the vent-air intake system.  
 L'appareil doit être ventilé à l'aide de l'ensemble d'évacuation propre à Napoleon. Référez au manuel d'installation pour les spécifications d'évacuation. Il est nécessaire de bien réinstaller et resceller l'évacuation après avoir exécuter l'entretien du système de prise d'air.

**Manifold Pressure:** 3.5" w.c. (NG) **Manifold Pressure:** 10" w.c. (P)  
**Minimum Supply Pressure:** 4.5" w.c. (NG) **Minimum Supply Pressure:** 11" w.c. (P)  
**Maximum Supply Pressure:** 7" w.c. (NG) **Maximum Supply Pressure:** 13" w.c. (P)  
**Pression au Collecteur:** 3.5" d'une colonne d'eau (GN) **Pression au Collecteur:** 10" d'une colonne d'eau (P)  
**Pression d'Alimentation Min.:** 4.5" d'une colonne d'eau (GN) **Pression d'Alimentation Min.:** 11" d'une colonne d'eau (P)  
**Pression d'Alimentation Max.:** 7" \*\* d'une colonne d'eau (GN) **Pression d'Alimentation Max.:** 13" \*\* d'une colonne d'eau (P)  
 \*\* Maximum inlet pressure not to exceed 13".

**Minimum clearance to combustible materials:** **Dégagements minimaux des matériaux combustibles:**  
 Top, sides & back; per standard spacers for framing and finishing materials. For non-combustible framing and finishing materials, see installation manual. **Top, côtés et arrière; selon les espacements de dégagements pour les matériaux d'ossature selon le manuel du propriétaire pour les matériaux de finition.**  
 Top X" Dessus X"  
 Floor X" Plancher X"  
 Sides X" Côtés X"  
 Back X" Arrière X"  
 Vent top X" Dessus du conduit d'évent X"  
 Vent sides & bottom X" Côtés et dessous du conduit d'évent X"  
 Recessed depth X" Profondeur d'encastrement une face X"  
 \*\*\* Mantel X" from appliance opening \*\*\* Tablette X" de l'ouverture de l'appareil  
 \*\*\* Maximum horizontal extension: X". See installation manual for greater extensions, minimum vent lengths and maximum vent lengths. **\*\*\* Extension horizontale maximale: X". Référez au manuel d'installation pour des extensions plus grandes, les longueurs d'évacuation minimales et maximums.**  
 Electrical rating: 115V, 60Hz. Less than 12 amperes. **Spécifications électriques: 115V, 60Hz. Moins de 12 ampères.**

**WOLF STEEL LTD.** 24 Napoleon Road, Barrie, ON, L4M 0G8 Canada **Serial Number / N° de Série: XXXX** **W385-XXXX**

**note:**  
 The rating plate must remain with the appliance at all times. It must not be removed.

This illustration is for reference only. Refer to the rating plate on the appliance for accurate information.

### 1.4 mobile home installation (model GDS28)

This appliance must be installed in accordance with the manufacturer's instructions and the Manufactured Home Construction and Safety Standard, Title 24 CFR, Part 3280, in the United States or the Mobile Home Standard, CAN/CSA Z240 MH Series, in Canada. This appliance is only for use with the type(s) of gas indicated on the rating plate.

This mobile/manufactured home listed appliance comes factory equipped with a means to secure the appliance. Built in appliances are equipped with 1/4" (6.4mm) diameter holes located in the front left and right corners of the base. Use appropriate fasteners, inserted through the holes in the base to secure. For free standing products contact your local authorized dealer / distributor for the appropriate securing kit. For mobile home installations, the appliance must be fastened in place. It is recommended that the appliance be secured in all installations. Always turn off the pilot and the fuel supply at the source, prior to moving the mobile home. After moving the mobile home and prior to lighting the appliance, ensure that the logs are positioned correctly.

This appliance is certified to be installed in an aftermarket permanently located, manufactured (mobile) home, where not prohibited by local codes.  
 This appliance is only for use with the type of gas indicated on the rating plate. This appliance is not convertible for use with other gases, unless a certified kit is used.

**Conversion Kits**  
 This appliance is field convertible between Natural Gas (NG) and Propane (P).  
 To convert from one gas to another, consult your Authorized dealer/distributor.

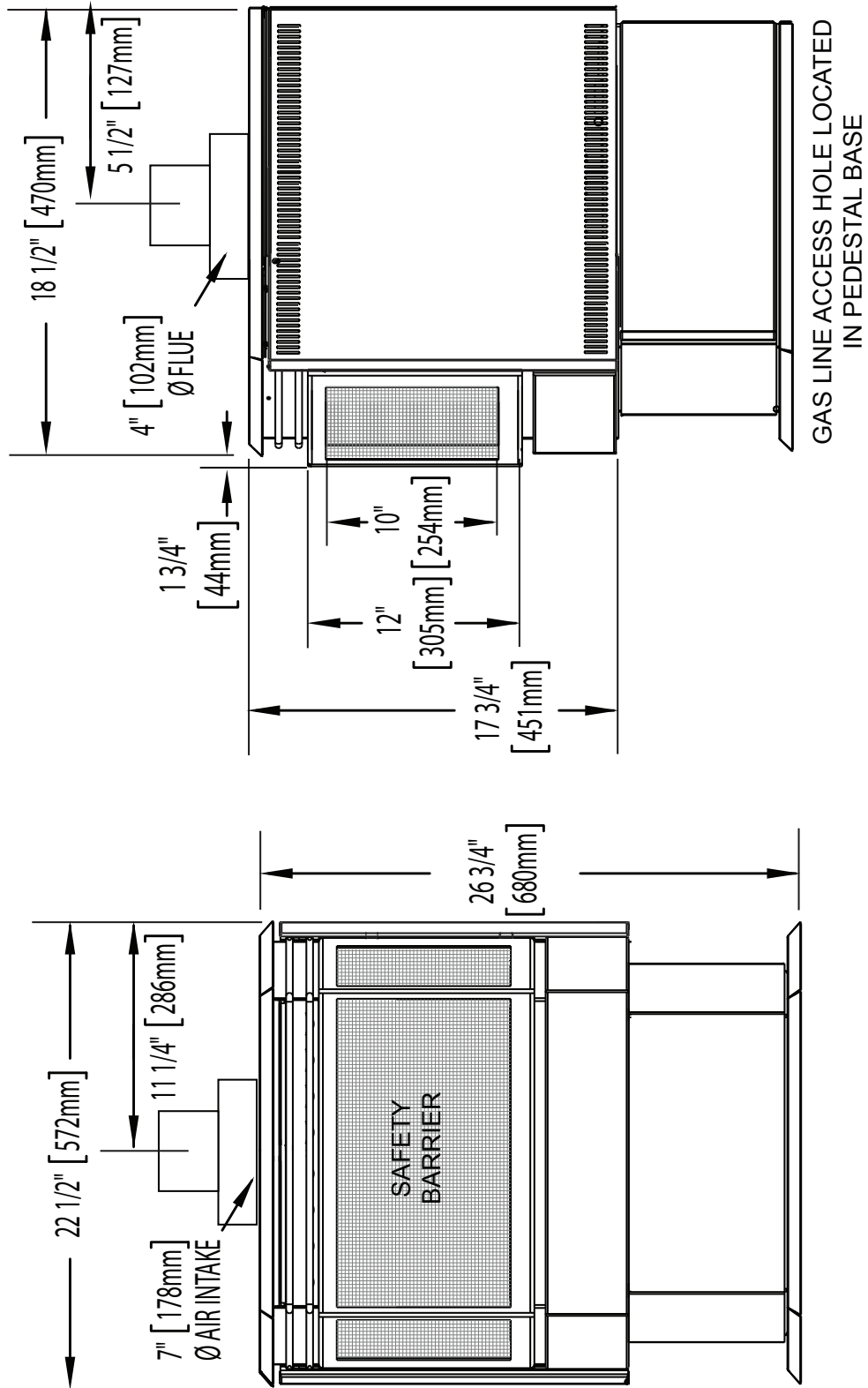

right side view

front view



**! WARNING**

- Risk of fire. Maintain specified air space clearances to vent pipe and appliance.
- The vent system must be supported every 3'(0.9m) for both vertical and horizontal runs. Use support ring assembly W010-0067 or equivalent non-combustible strapping to maintain the minimum clearance to combustibles for both vertical and horizontal runs. Spacers are attached to the inner pipe at predetermined intervals to maintain an even air gap to the outer pipe. This gap is required for safe operation. A spacer is required at the start, middle, and end of each elbow to ensure this gap is maintained. These spaces must not be removed.

**This appliance uses a 4" (102mm) exhaust / 7" (178mm) air intake vent pipe system. Refer to the section applicable to your installation.**

For safe and proper operation of the appliance, follow the venting instructions exactly. Deviation from the minimum vertical vent length can create difficulty in burner start-up and/or carboning. Under extreme vent configurations, allow several minutes (5-15) for the flame to stabilize after ignition. Although not a requirement, it is recommended for vent lengths that pass through unheated spaces (attics, garages, crawl spaces) be insulated with the insulation wrapped in a protective sleeve to minimize condensation. Provide a means for visually checking the vent connection to the appliance after the appliance is installed. Use a firestop, vent pipe shield or attic insulation shield when penetrating interior walls, floor or ceiling.

The vent terminal may be painted with a high temperature paint to match exterior colours. Use an outdoor paint suitable for 400°F (200°C). Application and performance of paint is the consumer's responsibility. Spot testing is recommended.

**note:**

If for any reason the vent air intake system is disassembled, re-install per the instructions provided for the initial installation.

This appliance must be installed with a continuous connection of exhaust and air intake vent pipes. Utilizing alternate constructions such as a chimney as part of the vent system is not permitted.

**A terminal shall not terminate directly above a sidewalk or paved driveway which is located between two single family dwellings and serves both dwellings. Local codes or regulations may require different clearances.**

**Do not allow the inside liner to bunch up on horizontal or vertical runs and elbows. Keep it pulled tight. A 1-1/4" (25.4mm - 6.4mm) air gap all around between the inner liner and outer appliance pipe is required for safe operation. Use a firestop when penetrating interior walls, floor or ceiling.**

Use only Wolf Steel, Simpson Dura-Vent, Selkirk Direct Temp, American Metal Amerivent or Metal-Fab venting components. Minimum and maximum vent lengths, for both horizontal and vertical installations, clearances from vent pipes to combustibles and air terminal locations as set out in this manual apply to all vent systems and must be adhered to. For Simpson Dura-Vent, Selkirk Direct Temp, American Metal Amerivent and Metal-Fab, follow the installation procedure provided with the venting components or on the website for your venting supplier.

A starter adaptor must be used with the following vent systems and may be purchased from the corresponding supplier:

Vent Manufacturer	Starter Adapter Part Number	Supplier	Website
Duravent	GDS924N	Wolf Steel	www.duravent.com
Amerivent	4DSC-N2	American Metal	www.americanmetalproducts.com
Direct Temp	4DT-AAN	Selkirk	www.selkirkcorp.com
SuperSeal	4DNA	Metal-Fab	www.mtlfab.com

For vent systems that provide seals on the inner exhaust flue, only the outer air intake joints must be sealed using a red high temperature silicone (RTV). This same sealant may be used on both the inner exhaust and outer intake vent pipe joints of all other approved vent systems except for the exhaust vent pipe connection to the appliance flue collar which must be sealed using the black high temperature sealant Mill Pac. High temperature sealant must be ordered separately.

When using Wolf Steel venting components, use only approved Wolf Steel termination kits: wall terminal kit **GD-175** (7/12" of venting included), or 1/12 to 7/12 pitch roof terminal kit **GD-110**, 8/12 to 12/12 roof terminal kit **GD-111**, flat roof terminal kit **GD-112**, or periscope kit **GD-180** (for wall penetration below grade) in conjunction with the appropriate venting components.

**For optimum flame appearance and appliance performance, keep the vent length and number of elbows to a minimum.**

**The air terminal must remain unobstructed at all times. Examine the air terminal at least once a year to verify that it is unobstructed and undamaged.**

**Rigid and flexible venting systems must not be combined. Different venting manufacturer components must not be combined.**

# venting

These vent kits allow for either horizontal or vertical venting of the appliance. The maximum allowable horizontal run is 20 feet (6.1m). The maximum allowable vertical vent length is 40 feet (12.2m). The maximum number of vent connections is two horizontally or three vertically (excluding the appliance and the air terminal connections) when using flexible venting.

Deviation from the minimum vertical vent length can create difficulty in burner start-up and / or carboning. Use an adjustable pipe as the final length of rigid piping to the stove for ease of installation.

## 2.1 typical vent installation

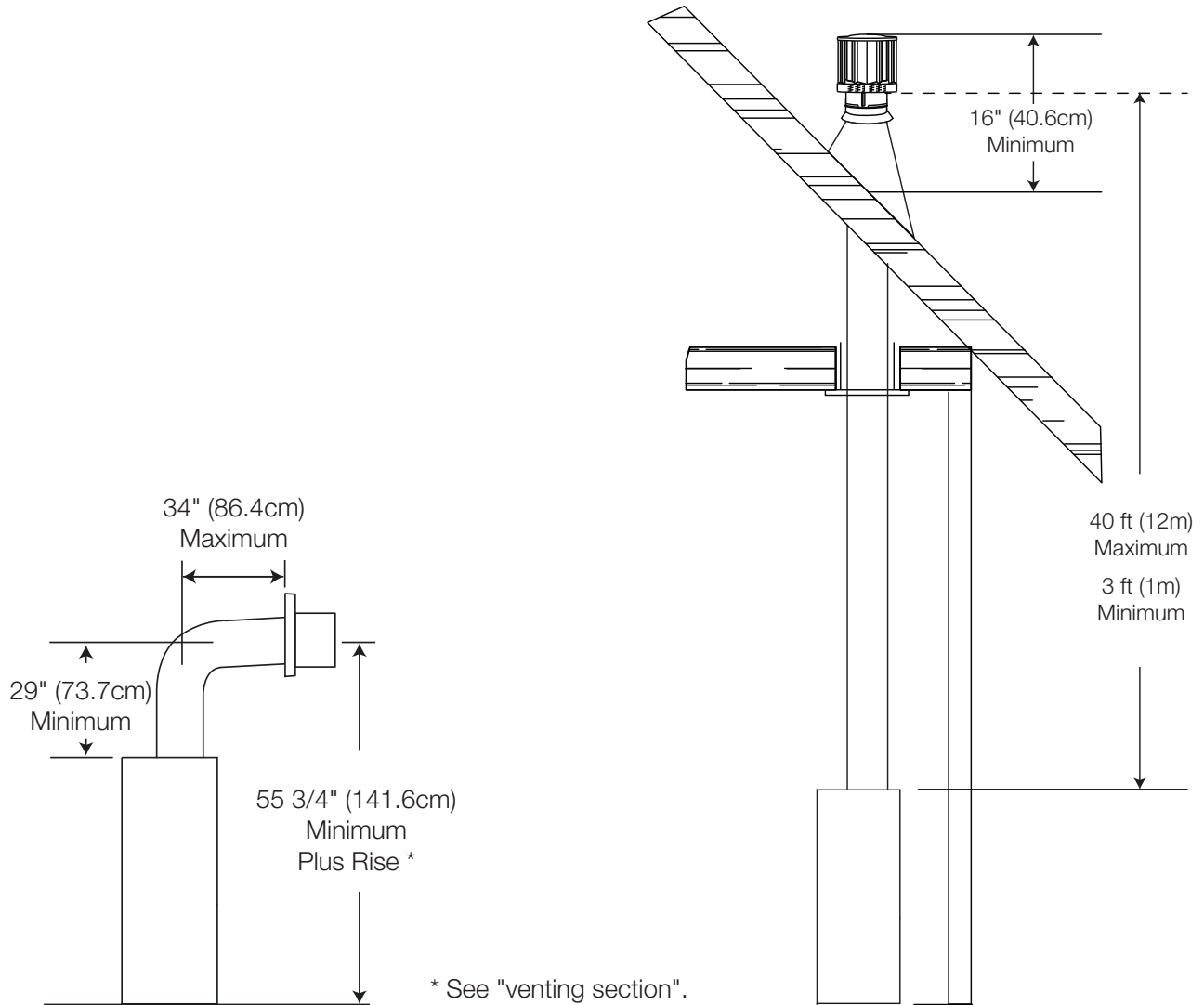

## 2.2 special vent installations

### 2.2.1 periscope termination

Use the periscope kit to locate the air termination above grade. The periscope must be installed so that when final grading is completed, the bottom air slot is located a minimum 12" (305mm) above grade. The maximum allowable vent length (including both rise and run) is 10' (3m) for a fireplace and 8' (2m) for a stove. An insulation sleeve is illustrated in the top vent image below, use only when supplied with the appliance.

(The insulation sleeve is not required with a stove appliance)

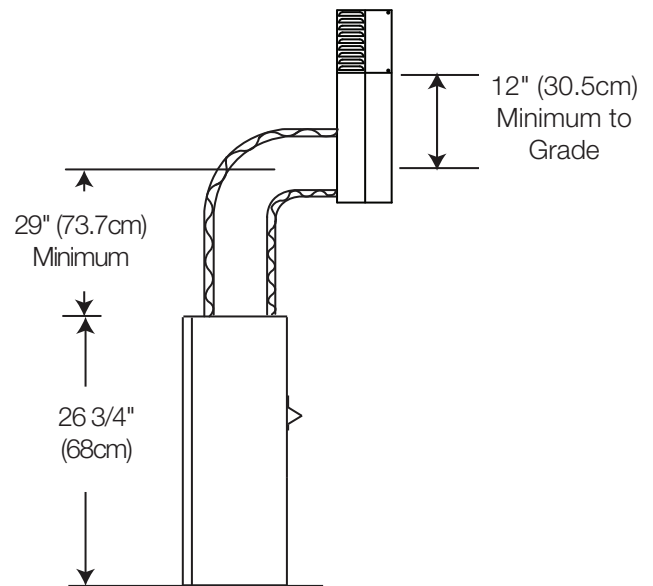

# venting

## 2.3 vent terminal clearances

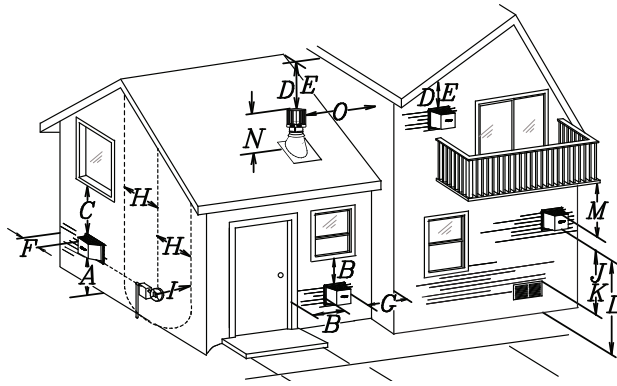

### Covered balcony applications ††\*

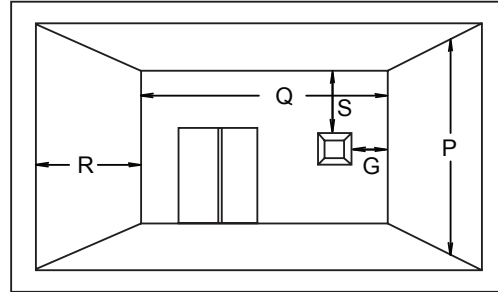

$Q_{MIN} = 3 \text{ feet}$ (0.9m)	$R_{MAX} = 2 \times Q_{ACTUAL}$	$R_{MAX} \leq 15 \text{ feet}$ (4.6m)
--------------------------------------	---------------------------------	--

**note:**  
Wall terminals are for illustration purposes only. Size and shapes may vary.

INSTALLATIONS			
	CANADA	U.S.A.	
<b>A</b>	12" (30.5cm)	12" (30.5cm)	Clearance above grade, veranda porch, deck or balcony.
<b>B</b>	12" (30.5cm) <sup>Δ</sup>	9" (229mm) <sup>Δ</sup>	Clearance to windows or doors that open.
<b>C</b>	12" (30.5cm)*	12" (30.5cm)*	Clearance to permanently closed windows.
<b>D</b>	18" (45.7cm)**	18" (45.7cm)**	Vertical clearance to ventilated soffits located above the terminal within a horizontal distance of 2' (0.6m) from the center line of the terminal.
<b>E</b>	12" (30.5cm)**	12" (30.5cm)**	Clearance to unventilated soffit.
<b>F</b>	0" (0mm)	0" (0mm)	Clearance to an outside corner wall.
<b>G</b>	0" (0mm)***	0" (0mm)***	Clearance to an inside <b>non</b> -combustible corner wall or protruding <b>non</b> -combustible obstructions (chimney, etc.).
	2" (51mm)***	2" (51mm)***	Clearance to an inside combustible corner wall or protruding combustible obstructions (vent chase, etc.).
<b>H</b>	3' (0.9m)	3' (0.9m)****	Clearance to each side of the center line extended above the meter / regulator assembly to a maximum vertical distance of 15' (4.6m).
<b>I</b>	3' (0.9m)	3' (0.9m)****	Clearance to a service regulator vent outlet.
<b>J</b>	12" (30.5cm)	9" (229mm)	Clearance to a non-mechanical air supply inlet to the building or a combustion air inlet to any other appliance.
<b>K</b>	6' (1.8m)	3' (0.9m) †	Clearance to a mechanical air supply inlet.
<b>L</b>	7' (2.1m) ‡	7' (2.1m) ****	Clearance above a paved sidewalk or paved driveway located on public property.
<b>M</b>	12" (30.5cm)††	12" (30.5cm)****	Clearance under a veranda, porch, deck or overhang.
<b>N</b>	16" (40.6cm)	16" (40.6cm)	Clearance above the roof.
<b>O</b>	2' (0.6m)†*	2' (0.6m) †*	Clearance from an adjacent wall including neighbouring buildings.
<b>P</b>	8' (2.4m)	8' (2.4m)	Roof must be <b>non</b> -combustible without openings.
<b>Q</b>	3' (0.9m)	3' (0.9m)	See chart for wider wall dimensions.
<b>R</b>	6' (1.8m)	6' (1.8m)	See chart for deeper wall dimensions. The terminal shall not be installed on any wall that has an opening between the terminal and the open side of the structure.
<b>S</b>	12" (30.5cm)	12" (30.5cm)	Clearance under a covered balcony

Δ The terminal shall not be located less than 6 feet under a window that opens on a horizontal plane in a structure with three walls and a roof.

\* Recommended to prevent condensation on windows and thermal breakage

\*\* It is recommended to use a heat shield and to maximize the distance to vinyl clad soffits.

\*\*\* The periscope requires a minimum 18 inches clearance from an inside corner.

\*\*\*\* This is a recommended distance. For additional requirements, check local codes.

† 3 feet above if within 10 feet horizontally.

‡ A vent shall not terminate where it may cause hazardous frost or ice accumulations on adjacent property surfaces.

†† Permitted only if the veranda, porch, or deck is fully open on a minimum of two sides beneath the floor.

†\* Recommended to prevent recirculation of exhaust products. For additional requirements, check local codes.

††\* Permitted only if the balcony is fully open on a minimum of one side.

**note:**  
Clearances are to be in accordance with local installation codes and the requirements of the gas supplier. In their absence, clearances are to be as listed above and are based on national codes.

## 2.4 vent flow charts

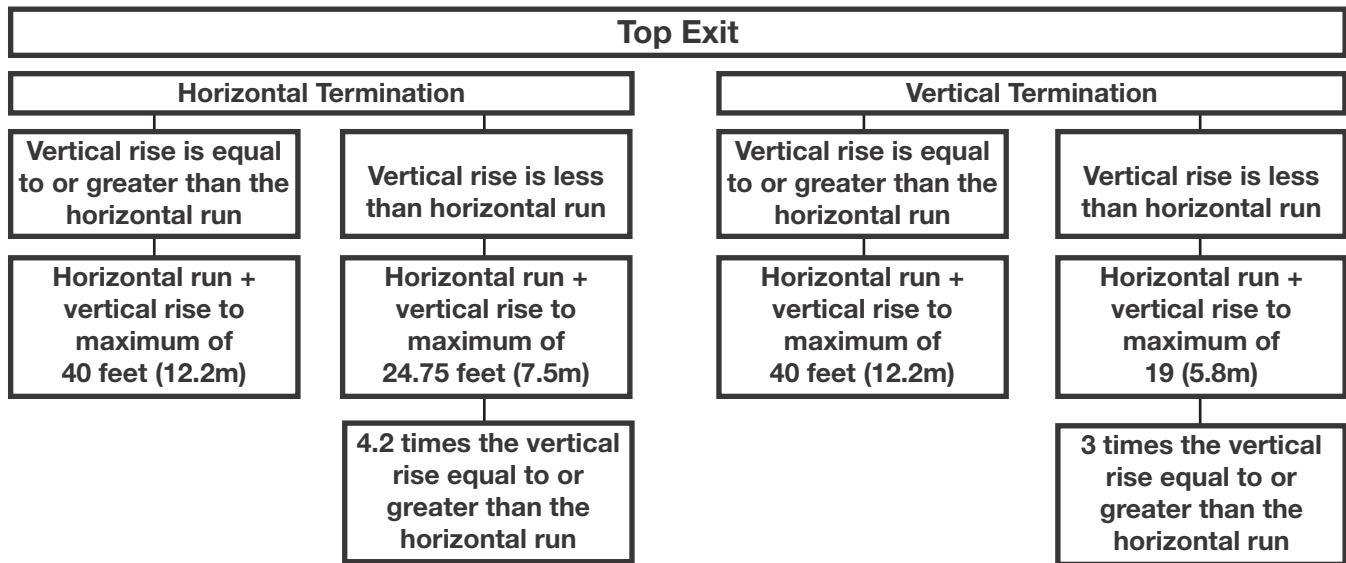

## 2.5 definitions

For the following symbols used in the venting calculations and examples are:

> - greater than

≥ - equal to or greater than

< - less than

≤ - equal to or less than

$H_T$  - total of both horizontal vent lengths ( $H_r$ ) and offsets ( $H_o$ ) in feet

$H_R$  - combined horizontal vent lengths in feet

$H_{O_1}$  - offset factor: .03 (total degrees of offset - 90°\*) in feet

$H_{O_2}$  - offset factor: .03 (total degrees of offset - 135°\*) in feet

$V_T$  - combined vertical vent lengths in feet

## 2.6 elbow vent lengths

	Feet	Inches	Millimeters
1°	0.03	0.5	12.7
15°	0.45	6.0	152.4
30°	0.9	11.0	279.4
45°	1.35	16.0	406.4
90°*	2.7	32.0	812.8

\* The first 90° offset has a zero value and is shown in the formula as - 90°

\* The first 45° and 90° offset have a zero value and is shown in the formula as -45° and -90° respectively or -135° when combined **(for 45° exit only)**.

## 2.7 horizontal termination

$$(H_T) \leq (V_T)$$

Simple venting configuration (only one 90° elbow)

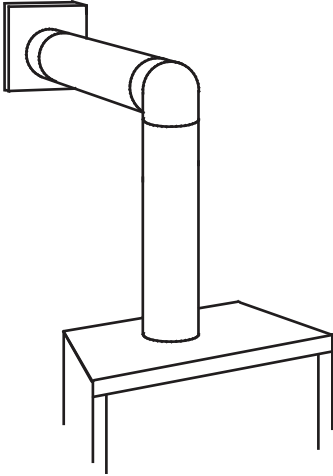

REQUIRED  
VERTICAL RISE  
IN FEET  
(METERS)  $V_T$

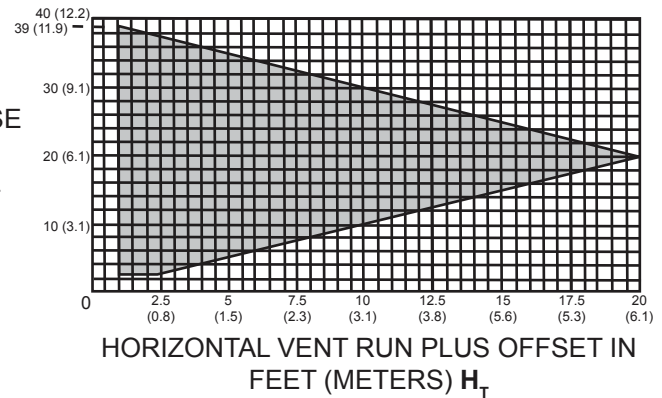

The shaded area within the lines represents acceptable values for  $H_T$  and  $V_T$

For vent configurations requiring more than one 90° elbow, the following formulas apply:

Formula 1:  $H_T \leq V_T$

Formula 2:  $H_T + V_T \leq 40$  feet (12.2m)

Example:

$$V_1 = 3 \text{ FT (0.9m)}$$

$$V_2 = 8 \text{ FT (2.4m)}$$

$$V_T = V_1 + V_2 = 3 \text{ FT (0.9m)} + 8 \text{ FT (2.4m)} = 11 \text{ FT (3.4m)}$$

$$H_1 = 2.5 \text{ FT (0.8m)}$$

$$H_2 = 2 \text{ FT (0.6m)}$$

$$H_R = H_1 + H_2 = 2.5 \text{ FT (0.8m)} + 2 \text{ FT (0.6m)} = 4.5 \text{ FT (1.4m)}$$

$$H_O = .03 \text{ (three } 90^\circ \text{ elbows - } 90^\circ) = .03 (270^\circ - 90^\circ) = 5.4 \text{ FT (1.7m)}$$

$$H_T = H_R + H_O = 4.5 \text{ FT (1.4m)} + 5.4 \text{ FT (1.7m)} = 9.9 \text{ FT (3m)}$$

$$H_T + V_T = 9.9 \text{ FT (3m)} + 11 \text{ FT (3.4m)} = 20.9 \text{ FT (6.4m)}$$

Formula 1:  $H_T \leq V_T$

$$9.9 \text{ FT (3m)} \leq 11 \text{ FT (3.4m)}$$

Formula 2:  $H_T + V_T \leq 40 \text{ FT (12.2m)}$

$$20.9 \text{ FT (6.4m)} \leq 40 \text{ FT (12.2m)}$$

Since both formulas are met, this vent configuration is acceptable.

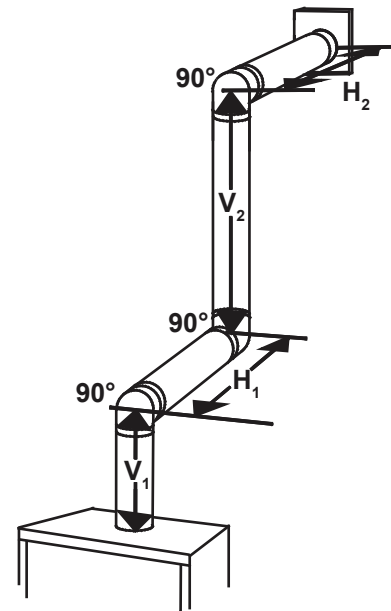

**$(H_T) > (V_T)$**

Simple venting configuration (only one 90° elbow)

See graph to determine the required vertical rise  $V_T$  for the required horizontal run  $H_T$ .

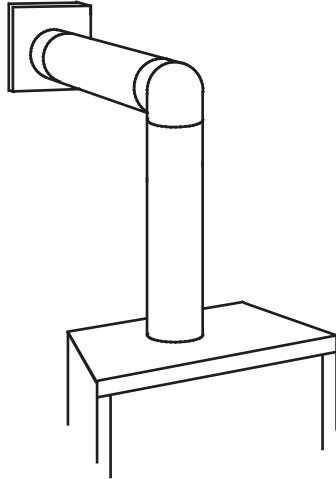

REQUIRED VERTICAL RISE IN INCHES (MILLIMETERS)  $V_T$

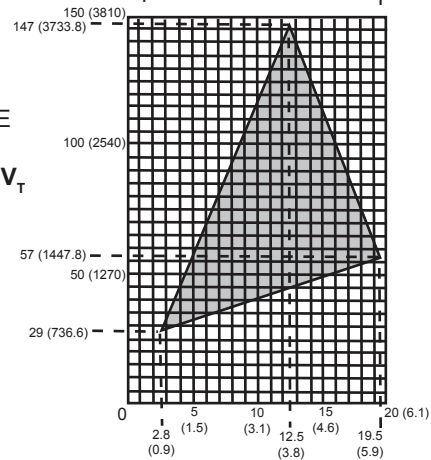

HORIZONTAL VENT RUN PLUS OFFSET IN FEET (METERS)  $H_T$   
The shaded area within the lines represents acceptable values for  $H_T$  and  $V_T$

For vent configurations requiring more than one 90° elbow, the following formulas apply:

Formula 1:  $H_T \leq 4.2 V_T$

Formula 2:  $H_T + V_T \leq 24.75$  feet (7.5m)

Example:

$V_1 = V_T = 6$  FT (1.8m)

$H_1 = 3$  FT (0.9m)

$H_2 = 5$  FT (1.5m)

$H_R = H_1 + H_2 = 3$  FT (0.9m) + 5 FT (1.5m) = 8 FT (2.4m)

$H_O = .03$  (two 90° elbows - 90°) = .03 (180° - 90°) = 2.7 FT (0.8m)

$H_T = H_R + H_O = 8$  FT (2.4m) + 2.7 FT (0.8m) = 10.7 FT (3.3m)

$H_T + V_T = 10.7$  FT (3.3m) + 6 FT (1.8m) = 16.7 FT (5.1m)

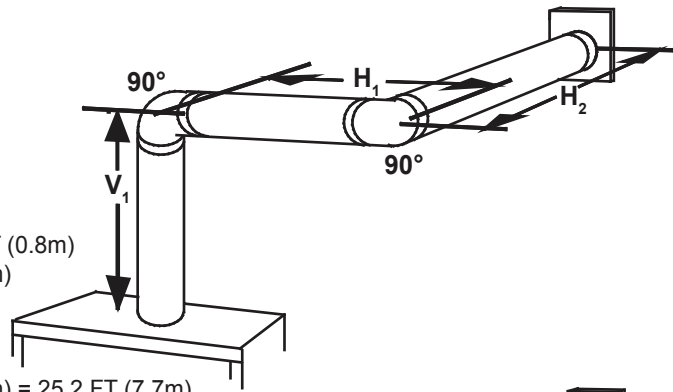

Formula 1:  $H_T \leq 4.2 V_T$   
 $4.2 V_T = 4.2$  FT (1.3m) x 6 FT (1.8m) = 25.2 FT (7.7m)

Formula 2:  $H_T + V_T \leq 24.75$  FT (7.5m)  
16.7 FT (5.1m)  $\leq$  24.75 (7.5m)

Since both formulas are met, this vent configuration is acceptable.

Example:

$V_1 = 4$  FT (1.2m)

$V_2 = 1.5$  FT (0.5m)

$V_T = V_1 + V_2 = 4$  FT (1.2m) + 1.5 FT (0.5m) = 5.5 FT (1.7m)

$H_1 = 2$  FT (0.6m)

$H_2 = 1$  FT (0.3m)

$H_3 = 1$  FT (0.3m)

$H_4 = 1.5$  FT (0.5m)

$H_R = H_1 + H_2 + H_3 + H_4 = 2$  FT (0.6m) + 1 FT (0.3m) + 1 FT (0.3m) + 1.5 FT (0.5m) = 5.5 FT (1.7m)

$H_O = .03$  (four 90° elbows - 90°) = .03 (360° - 90°) = 8.1 FT (2.5m)

$H_T = H_R + H_O = 5.5$  FT (1.7m) + 8.1 FT (2.5m) = 13.6 FT (4.2m)

$H_T + V_T = 13.6$  FT (4.2m) + 5.5 FT (1.7m) = 19.1 FT (5.8m)

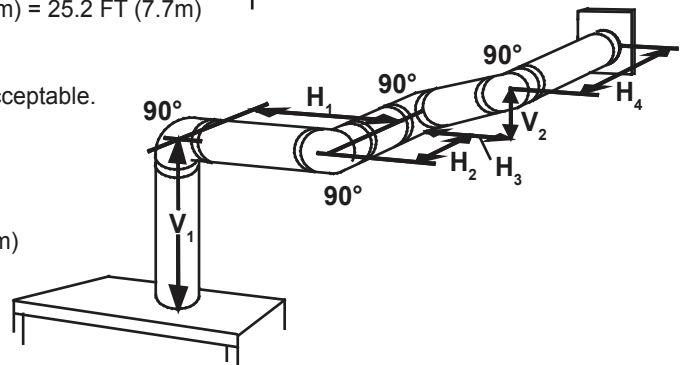

Formula 1:  $H_T \leq 4.2 V_T$   
 $4.2 V_T = 4.2$  FT (1.3m) x 5.5 FT (1.7m) = 23.1 FT (7m)  
13.6 FT (4.2m)  $\leq$  23.1 FT (7m)

Formula 2:  $H_T + V_T \leq 24.75$  FT (7.5m)  
19.1 FT (5.8m)  $\leq$  24.75 (7.5m)

Since both formulas are met, this vent configuration is acceptable.

## 2.8 top exit vertical termination

$$(H_T) \leq (V_T)$$

Simple venting configurations.

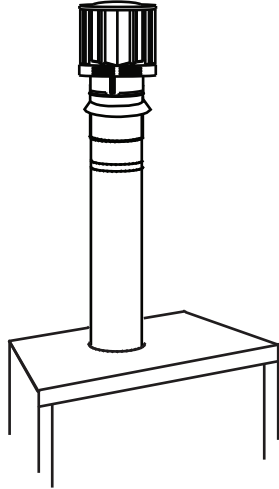

See graph to determine the required vertical rise  $V_T$  for the required horizontal run  $H_T$ .

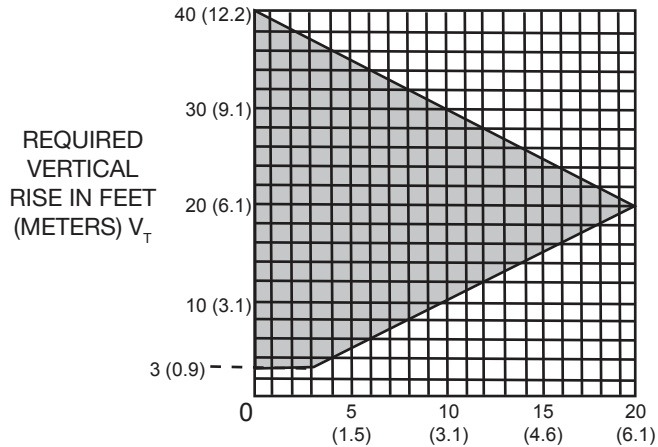

The shaded area within the lines represents acceptable values for  $H_T$  and  $V_T$

For vent configurations requiring one or more 90° elbows the following formulas apply:

Formula 1:  $H_T \leq V_T$

Formula 2:  $H_T + V_T \leq 40$  feet (12.2m)

Example:

$V_1 = 5$  FT (1.5m)

$V_2 = 6$  FT (1.8m)

$V_3 = 10$  FT (3.1m)

$V_T = V_1 + V_2 + V_3 = 5$  FT (1.5m) + 6 FT (1.8m) + 10 FT (3.1m) = 21 FT (6.4m)

$H_1 = 8$  FT (2.4m)

$H_2 = 2.5$  FT (0.8m)

$H_R = H_1 + H_2 = 8$  FT (2.4m) + 2.5 FT (0.8m) = 10.5 FT (3.2m)

$H_O = .03$  (four 90° elbows - 90°)

$= .03$  (360° - 90°) = 8.1 FT (2.5m)

$H_T = H_R + H_O = 10.5$  FT (3.2m) + 8.1 FT (2.5m) = 18.6 FT (5.7m)

$H_T + V_T = 18.6$  FT (5.7m) + 21 FT (6.4m) = 39.6 FT (12.1m)

Formula 1:  $H_T \leq V_T$   
18.6 FT (5.7m)  $\leq$  21 FT (6.4m)

Formula 2:  $H_T + V_T \leq 40$  FT (12.19m)  
39.6 FT (12.1m)  $\leq$  40 FT (12.2m)

Since both formulas are met, this vent configuration is acceptable.

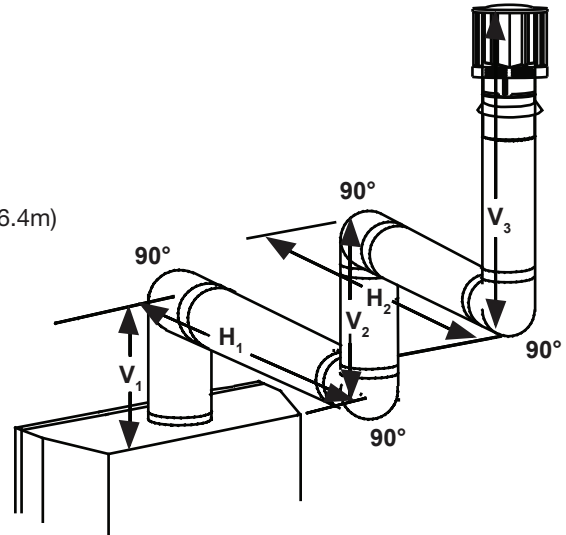



$(H_T) > (V_T)$

Simple venting configurations.

See graph to determine the required vertical rise  $V_T$  for the required horizontal run  $H_T$ .

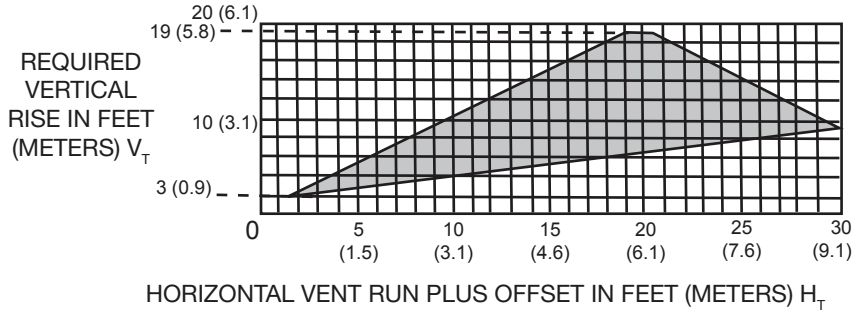
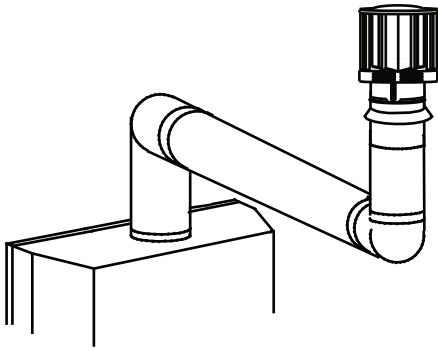

HORIZONTAL VENT RUN PLUS OFFSET IN FEET (METERS)  $H_T$

The shaded area within the lines represents acceptable values for  $H_T$  and  $V_T$

For vent configurations requiring more than two 90° elbows the following formulas apply:

Formula 1:  $H_T \leq 3V_T$

Formula 2:  $H_T + V_T \leq 40$  feet (12.2m)

Example:

$V_1 = 2$  FT (0.6m)

$V_2 = 1$  FT (0.3m)

$V_3 = 1.5$  FT (0.5m)

$V_T = V_1 + V_2 + V_3 = 2$  FT (0.6m) + 1 FT (0.3m) + 1.5 FT (0.5m) = 4.5 FT (1.4m)

$H_1 = 6$  FT (1.8m)

$H_2 = 2$  FT (0.6m)

$H_R = H_1 + H_2 = 6$  FT (1.8m) + 2 FT (0.6m) = 8 FT (2.4m)

$H_O = .03$  (four 90° elbows - 90°)

= .03 (360° - 90°) = 8.1 FT (2.5m)

$H_T = H_R + H_O = 8$  FT (2.4m) + 8.1 FT (2.5m) = 16.1 FT (4.9m)

$H_T + V_T = 16.1$  FT (4.9m) + 4.5 FT (1.4m) = 20.6 FT (6.3m)

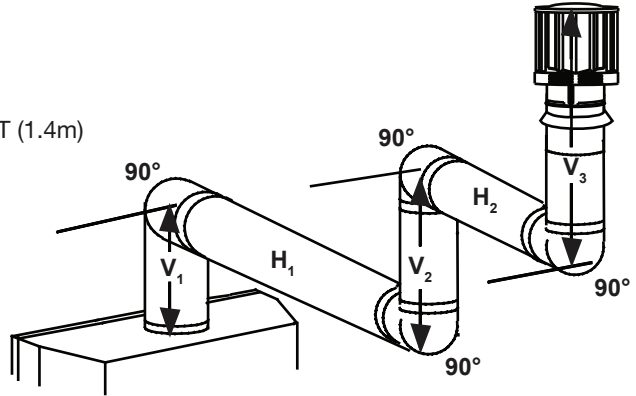

Formula 1:

$H_T \leq 3V_T$

$3V_T = 3$  FT (0.9m) x 4.5 FT (1.4m) = 13.5 FT (4.1m)

16.1 FT (4.9m) > 13.5 FT (4.1m)

Since this formula is not met, this vent configuration is unacceptable.

Formula 2:

$H_T + V_T \leq 40$  feet (12.2m)

20.6 FT (6.3m) ≤ 40 (12.2m)

Since only formula 2 is met, this vent configuration is unacceptable and a new appliance location or vent configuration will need to be established to satisfy both formulas.

## 2.9 vertical through existing chimney

**! WARNING**

- Risk of fire.
- Co-axial to co-linear venting configurations must only be used in a non-combustible chimney or enclosure. Installation in a combustible enclosure could result in a fire.

This appliance is designed to be attached to a 3" (76.2mm) co-linear aluminum flex vent system running the full length of a masonry chimney.

The flex liners accommodate any contours of a masonry chimney, however, it is necessary to keep the flexible liners as straight as possible. The inlet air collar of the termination cap must be connected to the air intake flex liner and the exhaust collar must be connected to the exhaust flexible liner.

Both Simpson DuraVent and Selkirk co-linear to co-axial adaptors have been approved on this appliance

**note:**

A vent adaptor will be required directly off the appliance.

Follow vent manufacturer's installation instructions.

Different manufacturer's venting components must not be combined. Once the preferred manufacturer's appliance adaptor has been attached, the remainder of the system must be that of the same manufacturer.

The only exception to this rule is to use Wolf Steel's approved 3" (76.2mm) flex liner and co-linear termination.

\* Measured from appliance flue collar to termination flue collar

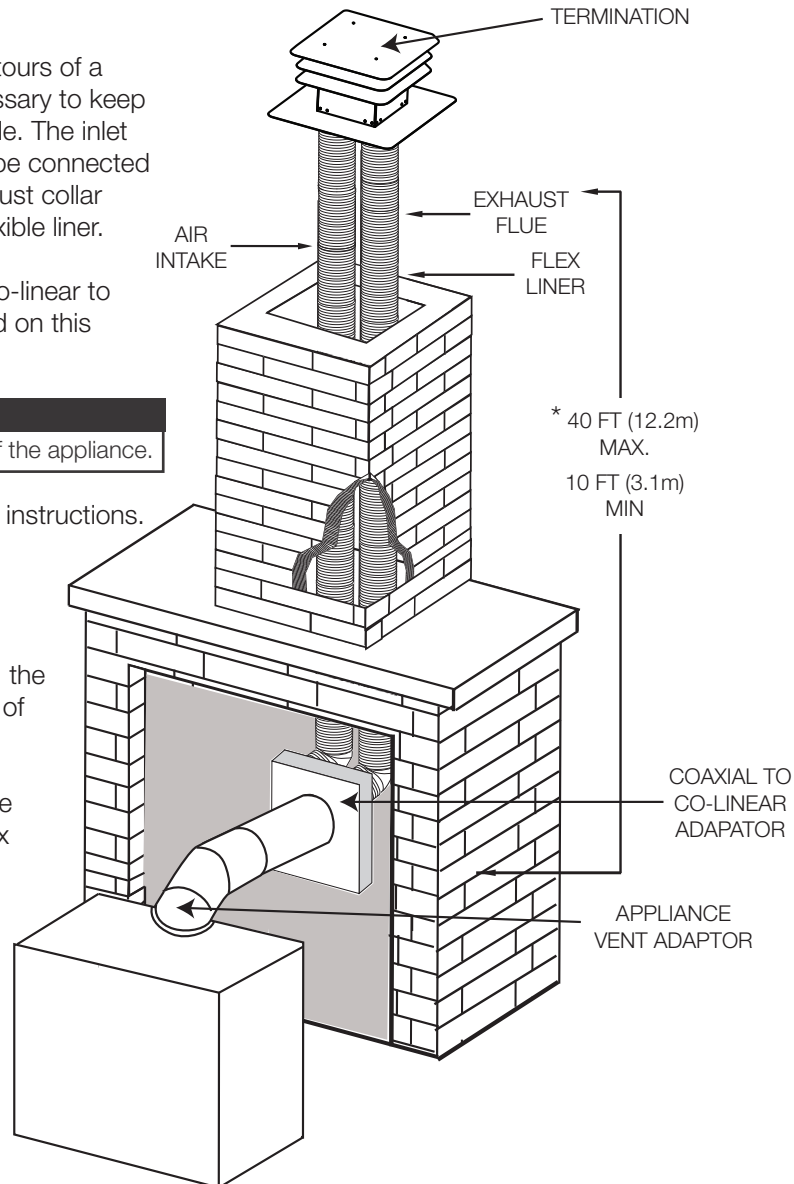

**! WARNING**

- Ensure to unpack all loose materials from inside the firebox prior to connecting the gas and electrical supply
- **If your appliance is supplied with a remote, ensure the remote receiver is in the “OFF” position prior to connecting the gas and electrical supply to the appliance.**
- For safe and proper operation of the appliance, follow the venting instructions exactly.
- **The appliance exhaust flue collar must be sealed using Mill Pac.** All exhaust and intake vent pipe joints must be sealed using red RTV high temp silicone sealant (W573-0002) (not supplied) or black high temp Mill Pac (W573-0007) (not supplied).
- If using pipe clamps to connect rigid vent components, a minimum of 3 screws must also be used to ensure the connection cannot slip off.
- Do not clamp the flexible vent pipe.
- Risk of fire, explosion, or asphyxiation. Improper support of the entire venting system may allow vent to sag and separate. Use vent run supports and connect vent sections per installation instructions.
- Risk of fire, do not allow loose materials or insulation to touch the vent pipe. Remove insulation to allow for the installation of the attic shield and to maintain clearances to combustibles.
- Do not fill the space between the vent pipe and enclosure with any type of material. Do not pack insulation or combustibles between ceiling firestops. Always maintain specified clearances around venting and firestop systems. Install wall shields and firestops as specified. Failure to keep insulation or other materials away from vent pipe may cause fire.
- **For gas stoves only:** If the appliance is installed directly on carpeting, vinyl tile, or other combustible material other than wood flooring, the appliance shall be installed on a metal or wood panel extending the full width and depth, unless otherwise tested.

**3.1 minimum clearances to combustibles**

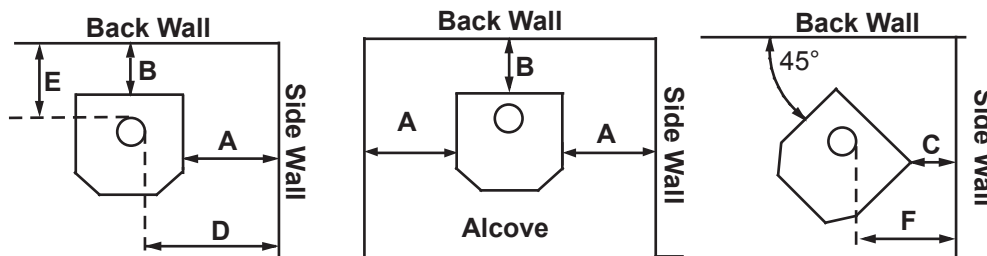

<b>A</b>	7" (178mm)	<b>D</b>	14 3/4" (375mm)
<b>B</b>	2" (51mm)	<b>E</b>	4" (102mm)
<b>C</b>	1" (25mm) *	<b>F</b>	9 1/2" (241mm)

- A minimum 20" (508mm) from appliance top to ceiling.

- A minimum 1" (25mm) clearance to combustibles from bottom and sides of vent pipe.

\* At a distance of 1" (25mm) from the wall, access to the blower switch, on/off switch or the blower power cord may not be practical.

**GDS28:**

**HORIZONTAL VENT SECTIONS:** A minimum clearance of 2" (51mm) at the top and 1" (25mm) at the bottom and sides of the vent pipe on all horizontal runs is required.

**VERTICAL VENT SECTIONS:** A minimum of 1" (25mm) all around the vent pipe on all vertical runs to combustibles is required.

**GS28:**

A minimum of 1" (25mm) all around the B vent pipe on both horizontal and vertical runs to combustibles is required.

**note:**

If the appliance is installed directly on carpeting, vinyl tile or other combustible material other than wood flooring, the appliance shall be installed on a metal or wood panel extending the full width and depth.

# installation

## 3.1.1 horizontal installation

### ! WARNING

- The firestop assembly must be installed with the vent shield to the top.
- Terminals must not be recessed into a wall or siding more than the depth of the return flange of the mounting plate.

This application occurs when venting through an exterior wall. Having determined the correct height for the air terminal location, cut and frame a hole in the exterior wall, as illustrated, to accommodate the firestop assembly. Dry fit the firestop assembly before proceeding to ensure the brackets on the rear surface fit to the inside surface of the horizontal framing.

The length of the vent shield may be cut shorter for combustible walls that are less than 8 1/2" (215.9mm) thick but the vent shield must extend the full depth of the combustible wall.

#### note:

Do not fill the air space between the firestop spacer and the exterior wall with any type of insulating material (i.e. spray foam).

- Assemble the shield to the spacer as shown, using the 3 shorter screws supplied.
- Place the firestop top so that the vent shield covers the top of the vent within the opening. Ensure that both spacer and shield maintain the required clearance to combustibles.
- Secure the spacer in place using the 4 longer screws supplied. Once the vent pipe is installed in its final position, apply sealant between the pipe and the firestop spacer.

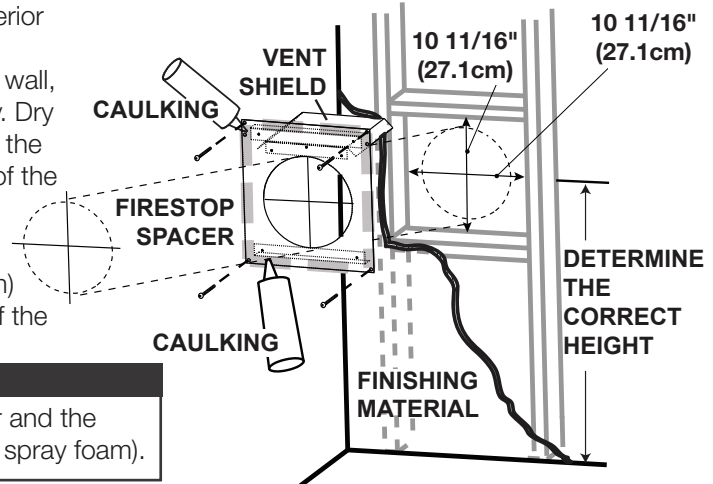

#### note:

The above is for illustration purposes only. Vents do not always pass through center of frame.

### 3.1.2 vertical installation

This application occurs when venting through a roof. Installation kits for various roof pitches are available from your authorized dealer / distributor. See the “accessories” section to order specific kits required.

- A. Determine the air terminal location, cut and frame a square opening, as illustrated, in the ceiling and the roof to provide the minimum 1" (25mm) clearance between the vent pipe and any combustible material. Try to center the vent pipe location midway between two joists to prevent having to cut them. Use a plumb bob to line up the center of the openings. A vent pipe shield will prevent any materials such as insulation, from filling up the 1" (25mm) air space around the pipe. Nail headers between the joist for extra support.
- B. Apply a bead of caulking (not supplied) to the framework or to the Wolf Steel vent pipe shield plate or equivalent (in the case of a finished ceiling), and secure over the opening in the ceiling. A firestop must be placed on the bottom of each framed opening in a roof or ceiling that the venting system passes through. Apply a bead of caulking all around and place a firestop spacer over the vent shield to restrict cold air from being drawn into the room or around the fireplace. Ensure that both spacer and shield maintain the required clearance to combustibles. Once the vent pipe is installed in its final position, apply red RTV silicone (W573-0002) (not supplied) between the pipe and the firestop assembly.
- C. In the attic, slide the vent pipe collar down to cover up the open end of the shield and tighten. This will prevent any materials, such as insulation, from filling up the 1" (25mm) air space around the pipe.

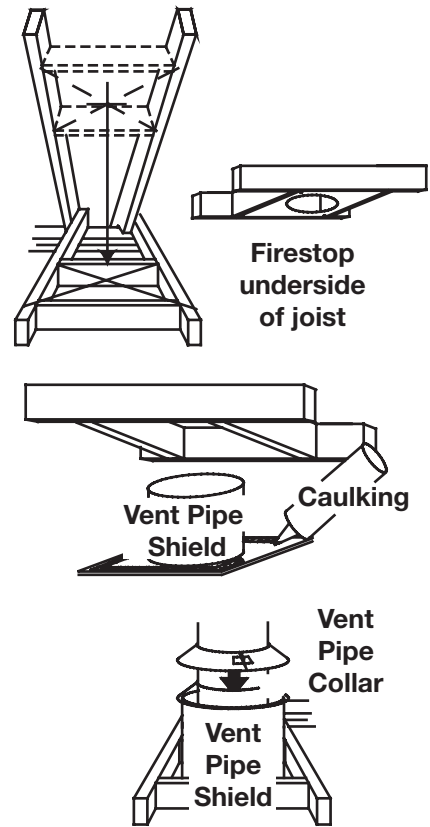

### 3.1.3 horizontal air terminal installation - model GDS28

- A. Stretch the inner flex pipe to the required length taking into account the additional length needed for the finished wall surface. Apply a heavy bead of the red RTV silicone (W573-0002) (not supplied) to the inner sleeve of the air terminal. Slip the vent pipe a minimum of 2" (50.8mm) over the inner sleeve of the air terminal and secure with a minimum of 3 screws.
- B. Using the outer flex pipe, slide over the outer combustion air sleeve of the air terminal and secure with a minimum of 3 screws. Seal using red RTV silicone (W573-0002) (not supplied).
- C. Insert the vent pipes through the firestop maintaining the required clearance to combustibles. Holding the air terminal (lettering in an upright, readable position), secure to the exterior wall and make weather tight by sealing with caulking (not supplied).
- D. If more vent pipe needs to be used to reach the fireplace, couple them together, as illustrated. The vent system must be supported approximately every 3 feet (0.9m) for both vertical and horizontal runs. Use non-combustible strapping to maintain the minimum clearance to combustibles.
- E. **Stove Appliances Only:** From inside the house, using Red RTV Silicone (W573-0002) (not supplied), seal between the vent pipe and the firestop. Then slide the black trim collar over the vent pipe up to the firestop.

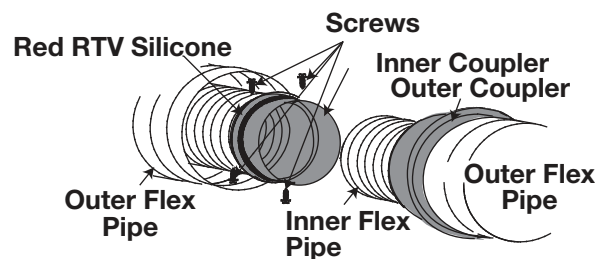
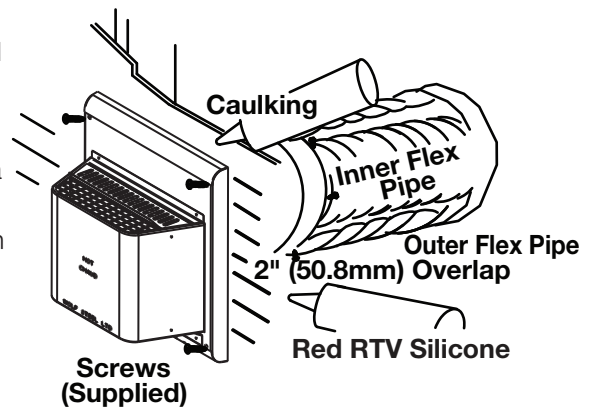

**The air terminal mounting plate may be recessed into the exterior wall or siding no greater than the depth of its return flange.**

## 3.1.4 vertical air terminal installation

### ! WARNING

- Maintain a minimum 2" (51mm) space between the air inlet base and the storm collar.

#### note:

Fastening hardware provided with appropriate roof terminal and liner kits.

- Fasten the roof support to the roof using 6 screws. The roof support is optional. In this case, the venting is to be adequately supported using either an alternate method suitable to the authority having jurisdiction or the optional roof support.
- Stretch the inner flex pipe to the required length. Slip the inner flex pipe a minimum of 2" (51mm) over the inner pipe of the air terminal connector and secure with a minimum of three screws, when 4/7, 5/8 and 3/5 venting is used and a minimum of six screws when using 8/10 or 8/11 venting. Seal using a heavy bead of red RTV silicone sealant (W573-0002) (not supplied).
- Repeat using the outer flex pipe, using a heavy bead of red RTV silicone sealant (W573-0002) (not supplied) and a minimum of three screws, when 4/7, 5/8 and 3/5 venting is used and a minimum of six screws when using 8/10 or 8/11 venting.
- Thread the air terminal connector / vent pipe assembly down through the roof. The air terminal must be positioned vertically and plumb. Attach the air terminal connector to the roof support, ensuring that the top of the air terminal is 16" (40.6cm) above the highest point that it penetrates the roof.
- Remove nails from the shingles, above and to the sides of the air terminal connector. Place the flashing over the air terminal connector leaving a min. 3/4" (19mm) of the air terminal connector showing above the top of the flashing. Slide the flashing underneath the sides and upper edge of the shingles. Ensure that the air terminal connector is properly centered within the flashing, giving a 3/4" (19mm) margin all around. Fasten to the roof. Do not nail through the lower portion of the flashing. Make weather-tight by sealing with caulking. Where possible, cover the sides and top edges of the flashing with roofing material.
- Aligning the seams of the terminal and air terminal connector, place the terminal over the air terminal connector making sure the vent pipe goes into the hole in the terminal. Secure with a minimum of three screws, when 4/7, 5/8 and 3/5 venting is used and a minimum of six screws when using 8/10 or 8/11 venting.
- Apply a heavy bead of weatherproof caulking 2" (51mm) above the flashing. Install the storm collar around the air terminal and slide down to the caulking. Tighten to ensure that a weather-tight seal between the air terminal and the collar is achieved.
- If more vent pipe needs to be used to reach the appliance, see "**horizontal air terminal installation**" section.

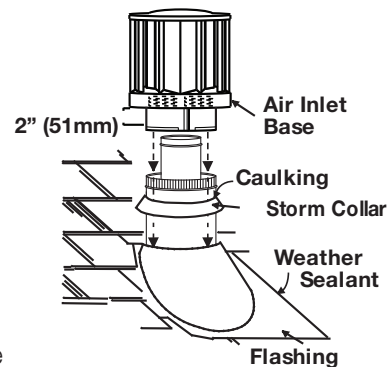
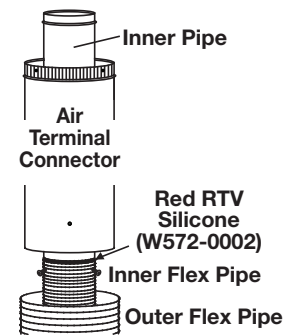
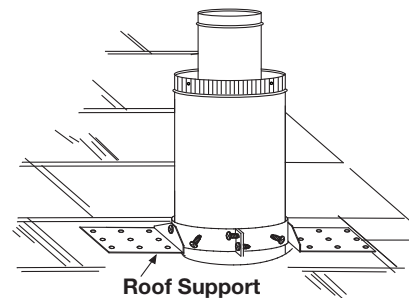

### 3.2 appliance vent connection

- A. Attach the adjustable pipe to the last section of rigid pipe. Secure with screws and seal.
- B. Install the inner flex pipe to the appliance. Secure with a minimum of three screws and flat washers when installing 3”/5”, 4”/7” or 5”/8” venting, or six screws and flat washers when installing 8”/10” or 8”/11” venting. Seal the joint and screw holes using Mill Pac sealant (W573-0007) (not supplied).
- C. Run a bead of high temperature red RTV silicone sealant (W573-0002) (not supplied) around the inside of the air intake collar. Pull the adjustable pipe a minimum 2” (50.8mm) into the air intake collar.

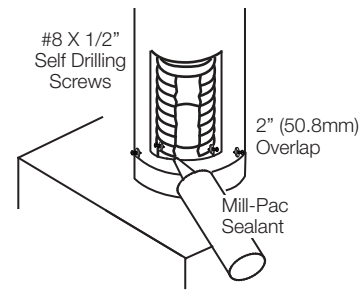

**note:**

Always finish vent system installation with the appliance vent connection. Ensure that the sealant is not visible on the exterior pipes once installation is completed. An optional decorative black band may be available with this appliance. In the event that the venting must be disassembled, care must be taken to reseal the venting.

### 3.3 natural vent specifics

#### 3.3.1 chimney installation

## ! WARNING

- A chimney venting this appliance shall not vent any solid fuel burning appliance.

Three types of chimney systems may be used with this appliance.

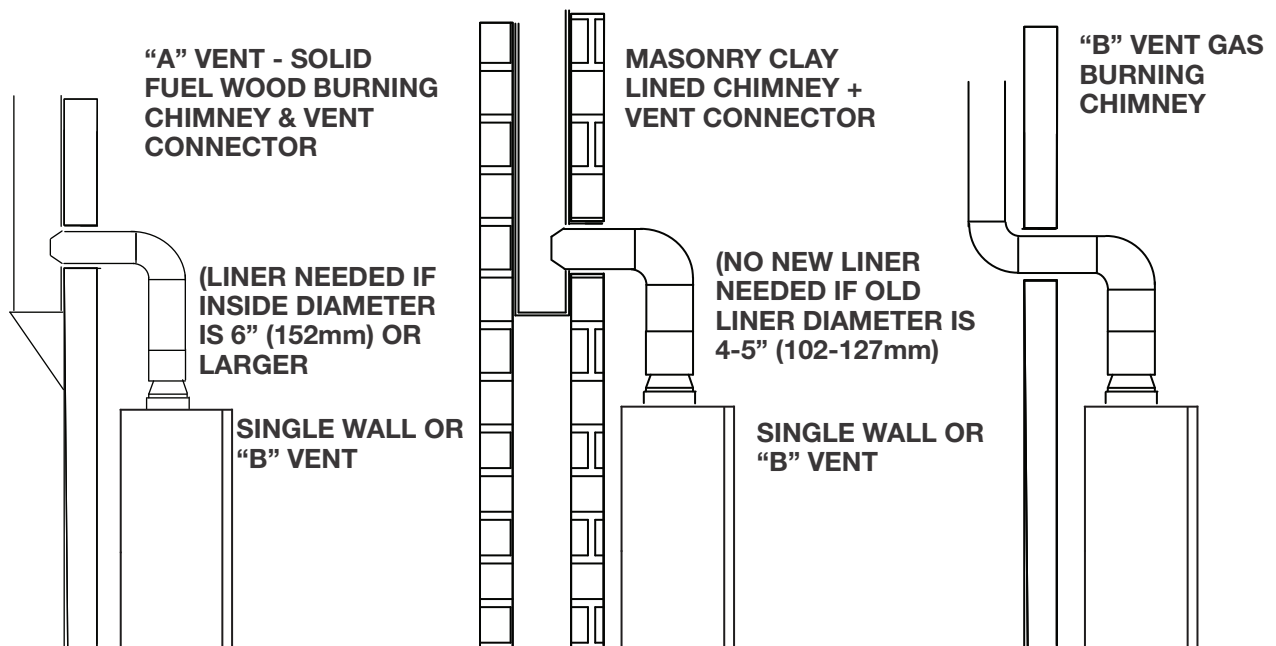

All horizontal runs must have a 1/4” (6.4mm) rise per foot (0.3m)

#### 3.3.2 combustion air

This appliance needs air for safe operation and must be installed in such a way that adequate combustion air is available.

# installation

## 3.3.3 installing natural vent

Follow the instructions of the natural vent manufacturer for chimney installation.

- A. Remove and discard the two combustion air cover plates and gaskets located on the rear panel of the appliance.
- B. Replace the four screws per side to secure the rear panel to the appliance.
- C. Remove the spill switch bracket from the rear of the adapter.
- D. Gently pull the two wire terminals (located inside the 7" (178mm) flue collar at the top of the appliance) out approximately 8" (203mm).
- E. Bring the wires through the lower hole in the adapter and out the spill switch opening. To pass the wires through the hole more easily, temporarily tape the two terminals together.
- F. With the spill switch opening aligned to the back of the appliance, push the crimped edge of the adapter in to the appliance flue collar.
- G. Connect the wire terminals to the spill switch and re-secure the bracket.
- H. Secure the terminal block into place as shown with the screw supplied.
- I. Unscrew the wire access cover plate from the rear right hand side below the firebox. Remove and discard the gasket. Remove the knockout from the cover plate and insert the protective bushing. Pull both spill switch wires through the bushing taking up any slack. Replace the cover plate.

**FOR MILLIVOLT:** Disconnect one of the black on/off switch wires and attach to the other side of the terminal block. Connect the remaining wires (1 black - 1 white) with 1/4" connectors to TP/TH and TH on the gas valve.

**FOR ELECTRONIC:** Disconnect one of the black on/off switch wires connected to the control module and connect it to the other side of the terminal block. Connect the other white spill switch wire to the control module (see "wiring diagram (electronic)").

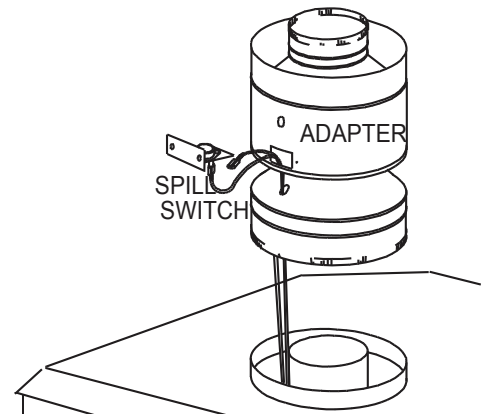
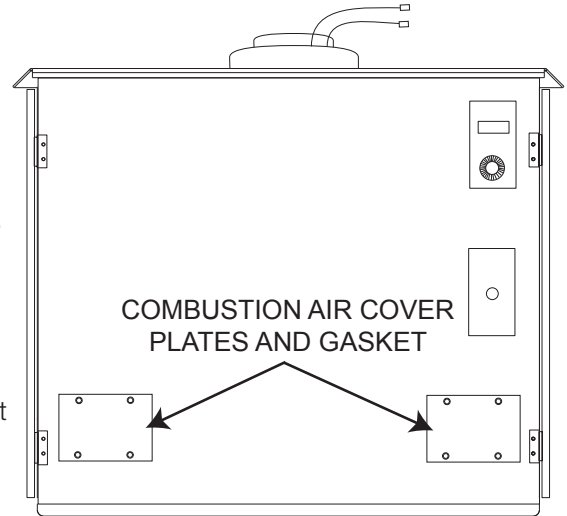
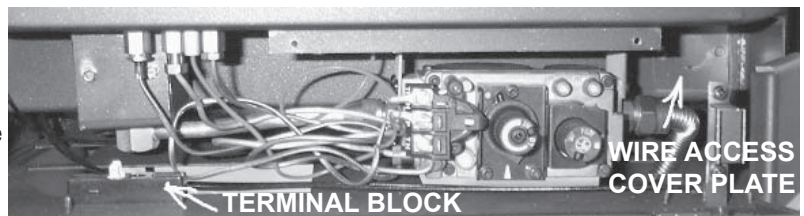

**note:**

If not converting, the wires are rated for high temperatures and may remain as is in the appliance collar.

For aesthetics, the adapter has been designed to accept a standard matte black 7" (178mm) stove pipe and the decorative band (standard with the GS-150KT). Both are available from your local authorized dealer / distributor.

## 3.3.4 natural vent

Attach the Natural Vent label (see below) in the control area of the appliance.

ATTACH THIS LABEL IN THE CONTROL AREA OF THE APPLIANCE.  
**THIS APPLIANCE HAS BEEN CONVERTED TO A NATURAL VENT MODEL.**

ATTACHEZ CET ÉTIQUETTE DANS LA RÉGION DE CONTRÔLE DU FOYER.  
**CET APPAREIL A ÉTÉ CONVERTI À UN MODÈLE À TIRAGE NATUREL.**

W385-0160 / B



### 3.3.5 adding vent sections

Add chimney sections, according to the manufacturer's installation instructions. If the chimney system passes through an attic space, a rafter radiation shield or attic insulation shield is required. The chimney must extend at least 3ft (0.9m) above its point of contact with the roof and at least 2ft (0.6m) higher than any wall, roof or building within 10ft (3.1m). If the chimney extends more than 5ft (1.5m) above the roof, it must be secured using a roof brace or guide wires. A raincap must be installed to avoid internal damage and corrosion.

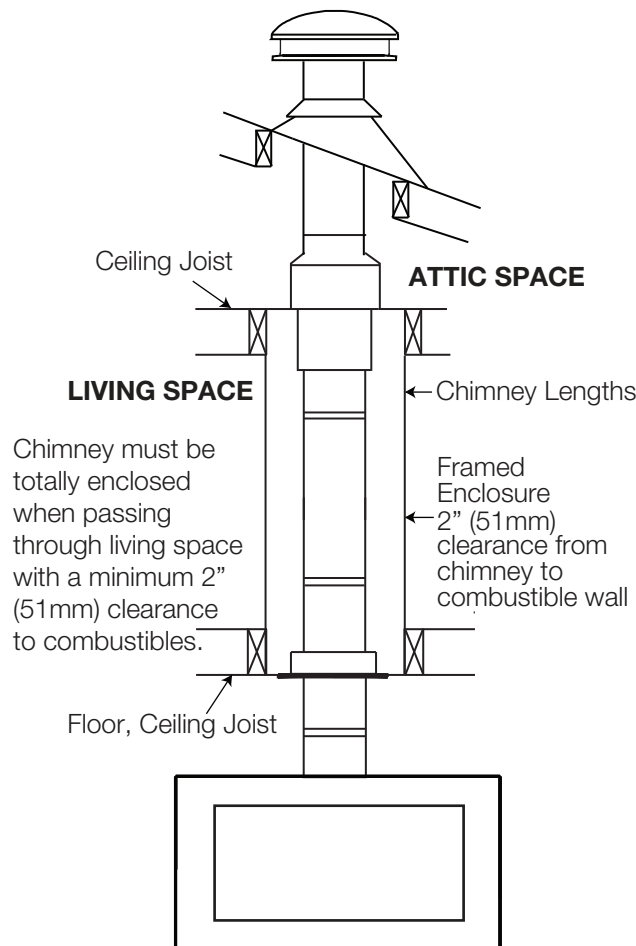
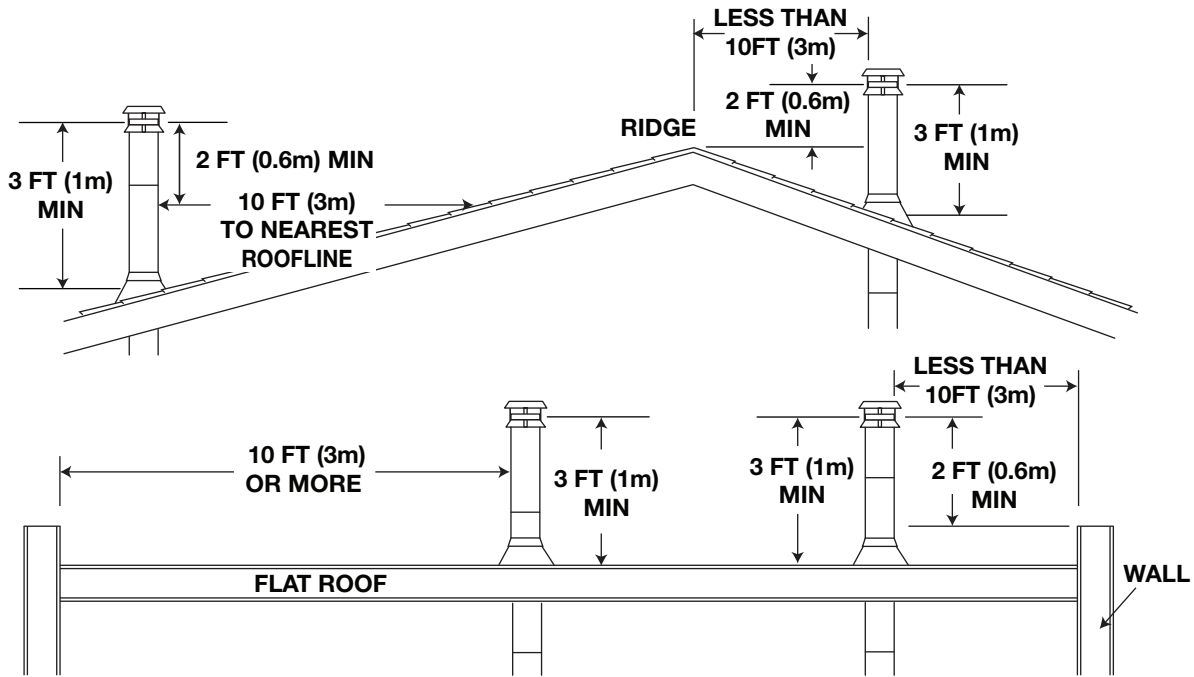

## 4.0 gas installation

### **! WARNING**

- Risk of fire, explosion, or asphyxiation. Ensure there are no ignition sources such as sparks or open flames.
- Support gas control when attaching gas supply pipe to prevent damaging gas line.
- Always light the pilot whether for the first time or if the gas supply has run out with the glass door opened or removed. Purging of the gas supply line should be performed by a qualified service technician. Ensure that a continuous gas flow is at the burner before closing the door. Ensure adequate ventilation. For gas and electrical locations, see “dimensions” section.
- All gas connections must be contained within the appliance when complete **(gas fireplaces only)**.
- High pressure will damage valve. Disconnect gas supply piping before testing gas line at test pressures above 1/2 PSIG.
- Valve settings have been factory set, do not change.

#### **Installation and servicing to be done by a qualified installer.**

- Move the appliance into position and secure.
- If equipped with a flex connector, the appliance is designed to accept a 1/2” (13mm) gas supply. Without the connector, it is designed to accept a 3/8” (9.5mm) gas supply. The appliance is equipped with a manual shut off valve to turn off the gas supply to the appliance.
- Connect the gas supply in accordance to local codes. In the absence of local codes, install to the current CAN/CSA-B149.1 Installation Code in Canada or to the current National Fuel Gas Code, ANSI Z223.1 / NFPA 54 in the United States.
- When flexing any gas line, support the gas valve so that the lines are not bent or kinked.
- The gas line flex-connector should be installed to provide sufficient movement for shifting the burner assembly on its side to aid with servicing components.
- Check for gas leaks by brushing on a soap and water solution. **Do not use open flame.**

## 5.0 optional wall switch / remote (millivolt)

### **! WARNING**

- Do not connect either the wall switch, thermostat or gas valve directly to 110 volt electricity.

For ease of accessibility, an optional remote wall switch or millivolt thermostat may be installed in a convenient location. Route a 2 strand, solid core millivolt wire from the valve to the wall switch or millivolt thermostat. The recommended maximum lead length depends on wire size:

<b>WIRE SIZE</b>	<b>MAX. LENGTH</b>
14 gauge (1.8mm)	100 feet (30.5m)
16 gauge (1.5mm)	60 feet (18.3m)
18 gauge (1.2mm)	40 feet (12.2m)

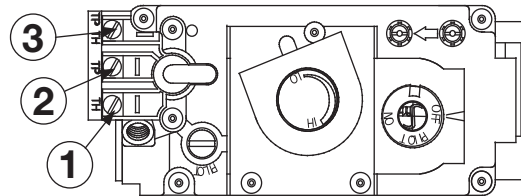

Disconnect the existing wires from terminals 1 and 3 (from the ON/OFF switch) and replace with the leads from the wall switch / millivolt thermostat.

## ! WARNING

- Risk of fire!
- Never obstruct the front opening of the appliance.
- The front of the appliance must be finished with any non-combustible materials such as brick, marble, granite, etc., provided that these materials do not go below the specified dimension, as illustrated.
- Do not strike, slam, or scratch. Do not operate appliance with glass removed, cracked, or scratched.
- Facing and/or finishing material must never overhang into the appliance opening.
- The glass door assembly is a safety device designed to pivot forward when relieving excess pressure that might occur. Finishing or other materials must not be located in the opening surrounding the door as this will interfere with the doors ability to relieve pressure.
- If applicable, drywall dust will penetrate into the blower bearings, causing irreparable damage. Care must be taken to prevent drywall dust from coming into contact with the blower or its compartment. Any damage resulting from this condition is not covered by the warranty policy.

### 6.1 safety screen installation and removal

## ! WARNING

- Glass may be hot. Do not touch glass until cooled.
- If equipped with door latches that are part of a safety system, they must be properly engaged. Do not operate the appliance with latches disengaged.
- Before door is removed, turn the appliance off and wait until appliance is cool to the touch. Doors are heavy and fragile so handle with care.

**A barrier designed to reduce the risk of burns from the hot viewing glass is provided with the appliance and must be installed.**

Open the side panels and control door on the appliance. Place the safety screen onto the door frame. Install the 4 screws on the top and bottom of the safety screen. Ensure the safety screen is installed correctly before closing the side panels and control door. Reverse these steps to remove the safety screen.

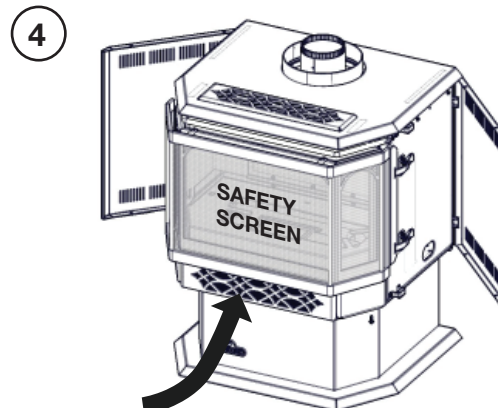
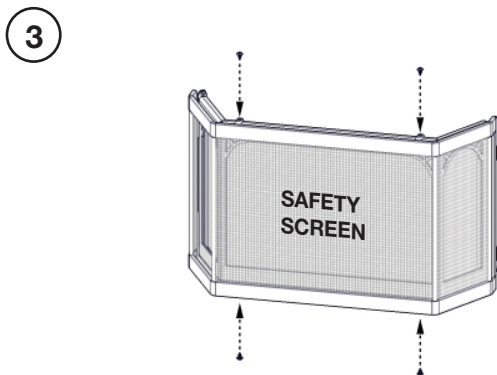
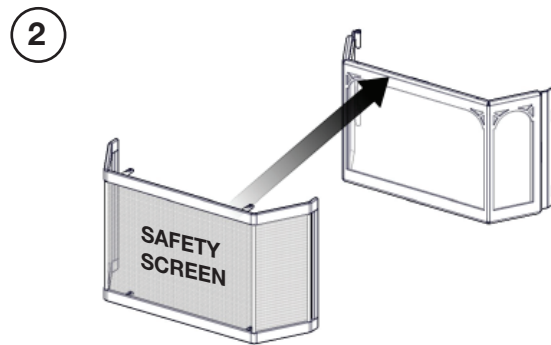
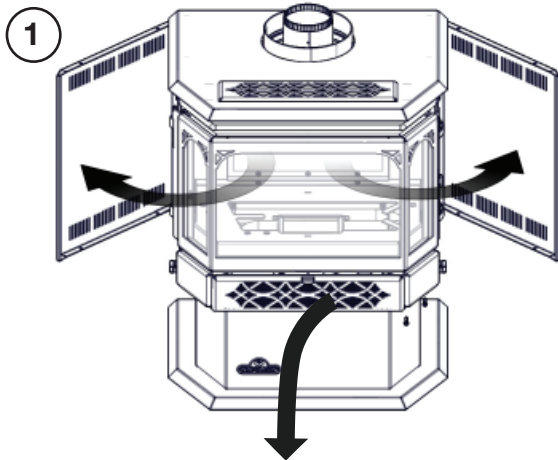

## 6.2 door closing and opening

**! WARNING**

- Glass may be hot. Do not touch glass until cooled.
- If equipped with door latches that are part of a safety system, they must be properly engaged. Do not operate the appliance with latches disengaged.
- Before door is removed, turn the appliance off and wait until appliance is cool to the touch. Doors are heavy and fragile so handle with care.

When installing the fire viewing door, a simple procedure must be followed in order to not damage the door.

- Open both side doors, exposing the bushings on the left and the latches on the right.
- Align the pins on the door to the bushings. Lower into place until both bushings touch.
- Engage the latch hooks into the door frame. Snap the rear handle hook to lock the latch closed.

**note:**

It may be necessary to lift the door when securing it to ensure that it is in a horizontal position.

To open the door, repeat in reverse order.

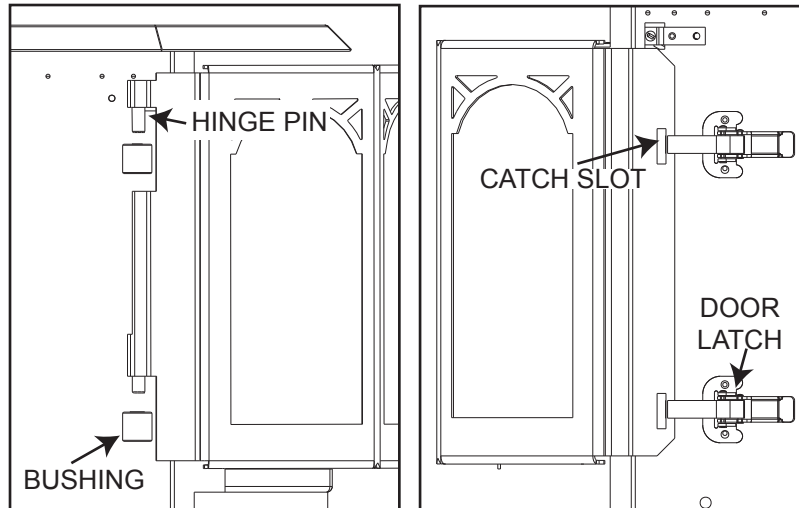

### 6.3 log placement

## ! WARNING

- Failure to position the logs in accordance with these diagrams or failure to use only logs specifically approved with this appliance may result in property damage or personal injury.
- Logs must be placed in their exact location in the appliance. Do not modify the proper log positions, since appliance may not function properly and delayed ignition may occur.
- The logs are fragile and should be handled with care.

**PHAZER™** logs, glowing embers, and charcoal embers, exclusive to Wolf Steel Ltd., glow when exposed to direct flame, and provide a unique and realistic glowing effect that is different in every installation. Use only certified **PHAZER™** logs, glowing embers, and charcoal embers available from your local authorized dealer / distributor. Log colours may vary. During the initial use of the appliance, the colours will become more uniform as colour pigments burn in during the heat-activated curing process.

- A.** Place the back log (1) into the firebox, pushing it as close to the firebox wall as possible and centered onto the log support pan.
- B.** Place the front log (2) on the ember screen lining up the studs with the holes on the bottom of the log.

**note:**

Ensure the left support tab and the two right support tabs are bent down to ensure the front burner flame does not get sucked beneath the front log.

- C.** Set the two cross-over logs (3, 4) into the pockets provided on both the front and rear logs as shown.

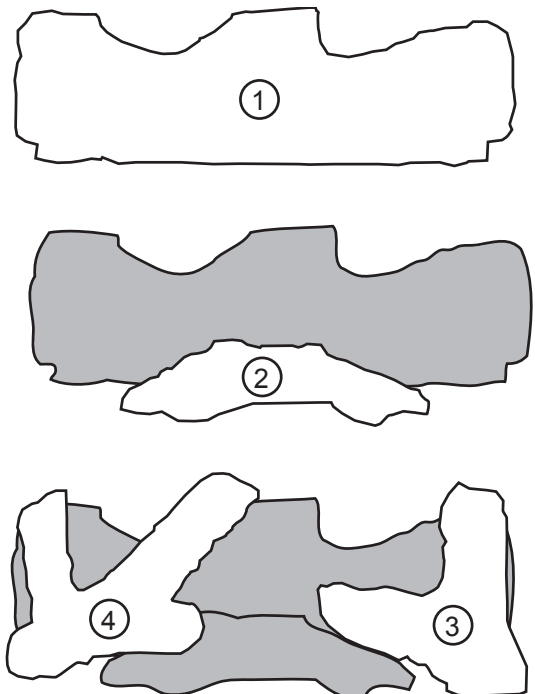

**note:**

The ember screen frame has a minimal adjustment distance. When heating with propane, ensure the ember screen is secured as close to the rear of the firebox as possible (**Fig. 1**). This will ensure the log's distance from the flames, and prevent excess carbon and soot. When heating with natural gas, ensure the ember screen is secured as close to the glass door as possible (**Fig. 2**). This will ensure the log's placement over the flames, and create a glowing effect on the log.

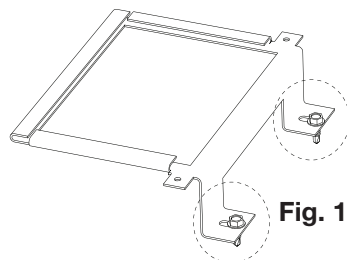

**Fig. 1**

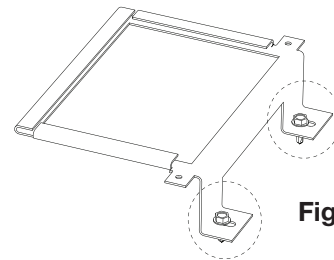

**Fig. 2**

## 6.4 glowing embers

### ! WARNING

- Completely blocking the burner ports can cause an incorrect flame pattern, carbon deposits and delayed ignition.

Tear the embers into pieces and loosely layer above the burner ports covering the burner area. Care should be taken to shred the embers into thin, small irregular pieces as only the exposed edges of the fibre hairs will glow.

**The ember material will only glow when exposed to direct flame; however, care should be taken to not block off the burner ports.**

Blocked burner ports can cause an incorrect flame pattern, carbon deposits and delayed ignition. **PHAZER™** logs glow when exposed to direct flame. Use only certified “glowing embers” and **PHAZER™** logs available from your local authorized dealer / distributor.

## 6.5 charcoal embers

### ! WARNING

- Do not block or close off the burner ports. Blocked ports can cause an incorrect flame pattern, carbon deposits and delayed ignition.
- When supplied, charcoal embers, charcoal lumps and vermiculite are not to be placed on the burner.

Randomly place the charcoal embers along the front and sides of the log support in a realistic manner.

**Fine dust found in the bottom of the bag should not be used.**

#### note:

Charcoal embers are not to be placed on the burner.

## 6.6 logo placement

Remove the backing of the logo supplied and centre over the logo installation holes, as indicated.

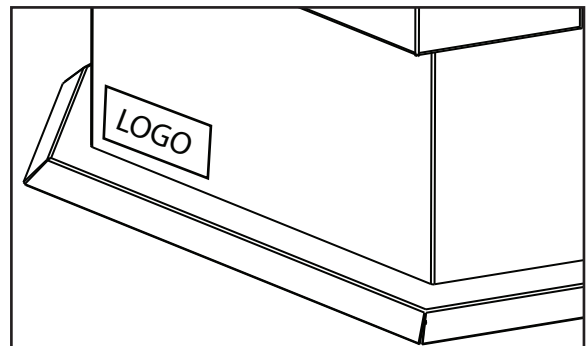

## 6.7 control access cover removal / installation

Lift the control access cover up then away from the appliance to remove. Reverse instructions to install control access cover.

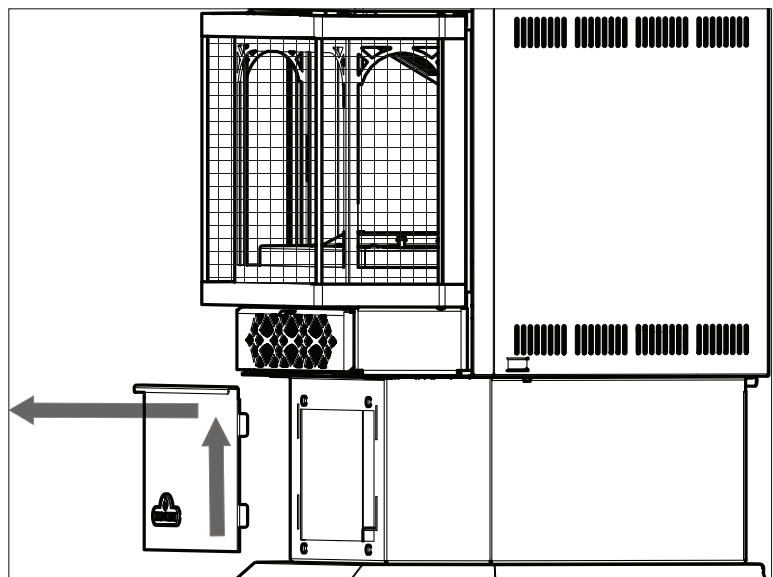

## 7.1 operating/lighting instructions

The on-off switch is located on the back of the appliance at the top left corner on models GDS28 and GS28.

When lit for the first time, the appliance will emit a slight odour for a few hours. This is a normal temporary condition caused by the "burn-in" of paints and lubricants used in the manufacturing process and will not occur again. Simply open a window to sufficiently ventilate the room. After extended periods of non-operation such as following a vacation or a warm weather season, the appliance may emit a slight odour for a few hours. This is caused by dust particles in the heat exchanger burning off. Open a window to sufficiently ventilate the room.

### **MODEL GS28 ONLY: SPILL SWITCH**

This is a thermally activated switch, attached to the back of the chimney adaptor, which senses the change in temperature and shuts down the gas valve in the event of a blocked or disconnected vent. It acts as a safety shut-off to prevent a build up of carbon monoxide or an explosion of unburned gases during start up. If the flue is blocked or has no "draw", the spill switch will automatically shut off the supply of gas within about 5-10 minutes.

### **MODEL GS28 ONLY: VENTING ACTION CHECK**

A CHECK FOR CORRECT VENTING ACTION MUST BE MADE BEFORE THE INSTALLED APPLIANCE IS LEFT WITH THE CUSTOMER. Test in the following manner:

- A.** Close all doors and windows in the room / start exhaust fans in the home / turn appliance blower off (if equipped).
- B.** Set controls to "high" and light the appliance.
- C.** Wait 5 minutes. Light a match and extend it 1" (25mm) into the hole located above the spill switch bracket on the adaptor.
- D.** Venting action is satisfactory if the flame stays lit. Venting action is unsatisfactory if the flame extinguishes.
- E.** If venting action is unsatisfactory, turn the appliance off, wait 10 minutes and try again. If the match does not stay lit, turn the appliance off and check for vent blockage or restriction. If necessary, consult with a qualified inspector.

## 8.0 wiring diagram (electronic)

### ! WARNING

- Do not wire 110 volts to the valve or wall switch.

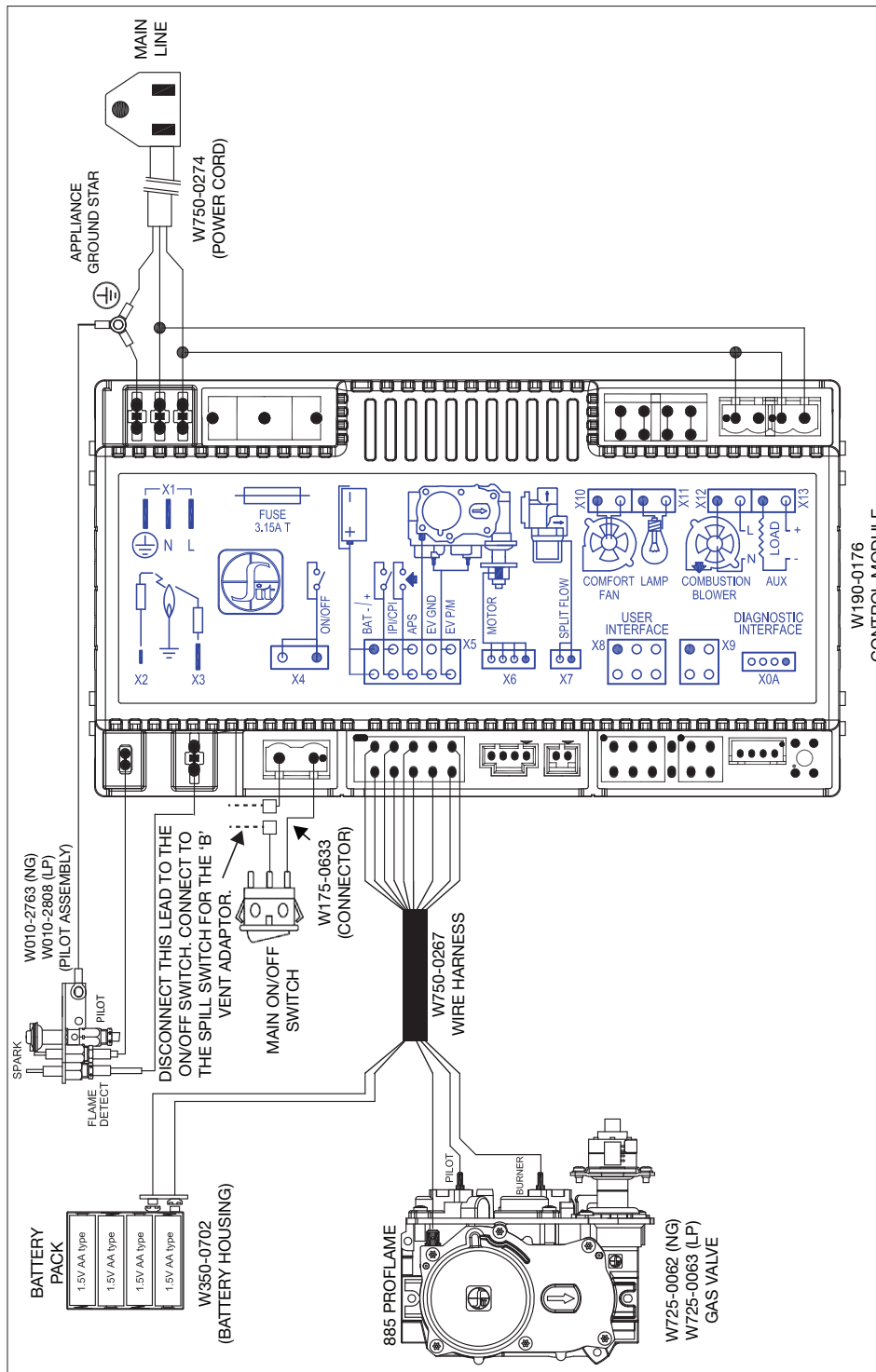

#### note:

This appliance comes equipped with a battery back-up. If this back-up is used, install 4 'AA' batteries (not supplied) into the holder and connect to the wire harness. Connect the battery holder to the wire harness before using the appliance. Place near the IPI board. If the back-up is used, it must be connected to this 6 volt battery pack (supplied). Do not connect to a 9 volt battery pack.



## ! WARNING

- If you do not follow these instructions exactly, a fire or explosion may result causing property damage, personal injury, or loss of life.
- If applicable, always light the pilot whether for the first time or if the gas supply has run out with the glass door opened or removed.

Ensure that a continuous gas flow is at the burner before installing the door. When lit for the first time, the appliance will emit an odor for a few hours. This is a normal temporary condition caused by the “burn-in” of paints and lubricants used in the manufacturing process and will not occur again. After extended periods of non-operation, such as, following a vacation or warm weather season, the appliance may emit a slight odor for a few hours. This is caused by dust particules in the heat exchanger burning off. In both cases, open a window to sufficiently ventilate the room.

### FOR YOUR SAFETY READ BEFORE LIGHTING

- Do not turn on if children or other at risk individuals are near the appliance.
- This appliance is equipped with an ignition device which automatically lights the pilot. Do not try to light the pilot by hand.
- Before operating, smell all around the appliance area for gas and next to the floor because some gas is heavier than air and will settle on the floor.
- Do not use this appliance if any part has been under water. Immediately call a qualified service technician to inspect the appliance and replace any part of the control system and any gas control which has been underwater.

### WHAT TO DO IF YOU SMELL GAS

- Turn off all gas to the appliance.
- Open windows.
- Do not try to light any appliance.
- Do not touch any electric switch; do not use any phone in your building.
- Immediately call your gas supplier from a neighbour's phone. Follow the gas supplier's instructions.
- If you cannot reach your gas supplier, call the fire department.

### LIGHTING INSTRUCTIONS

#### note:

This appliance is equipped with an ignition device which automatically lights the pilot. Do not try to light the pilot by hand.

- Stop! Read the above safety information on this label.
- Remove batteries from the transmitter and set thermostat to lowest setting, if equipped.
- Turn off all electrical power to the appliance.
- Open the glass door, if equipped.
- Turn the manual shut-off valve clockwise to the “OFF” position. (Shut-off valve is located on the flex connector).
- Wait five (5) minutes to clear out any gas. If you smell gas including near the floor, **STOP!** Follow the instructions above in the “WHAT TO DO IF YOU SMELL GAS” section. If you don't smell gas; close the glass door and go to the next step.
- Turn the manual shut-off valve counter clockwise to the “ON” position.
- Turn on all electrical power to the appliance and re-install the batteries into the transmitter. Set thermostat to desired setting, if equipped.
- Turn on the remote wall switch to the appliance.
- If the appliance will not operate, follow instructions “TO TURN OFF GAS” and call your service technician or gas supplier.

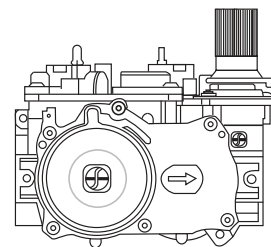

### TO TURN OFF GAS

- Set thermostat to lowest setting, if equipped.
- Turn off the remote wall switch to the appliance.
- Turn off all electric power to the appliance if service is to be performed.
- Turn manual shutoff valve clockwise to the “OFF” position. Do not force.

# operation (electronic)

## 9.1 pilot-on-demand

This appliance is equipped with an “On Demand” intermittent pilot ignition system (IPI) which also includes a continuous pilot ignition (CPI) mode with an integrated seven day timer. This system minimizes your appliance’s carbon footprint as well as reducing its annual fuel consumption and operating costs.

In IPI mode, the pilot will ignite prior to the main burner, when the appliance is turned on using a switch, remote or from a call for heat with the thermostat (if equipped). Once the appliance is turned off (or the call for heat is satisfied), the main burner and pilot flame will shut down.

The continuous (CPI) mode is intended to enhance the performance of the appliance during the startup phase in colder climates and extreme weather by keeping the system warm when the main burner is not in use. However, the timer feature provides the convenience that the appliance automatically switches off the pilot when the appliance has not been used for seven days to save unnecessary fuel consumption.

When the CPI function is turned on, the pilot will remain on after the main burner is turned off. A timer will then begin the countdown for approximately seven days before shutting off the pilot if the appliance is not used. This countdown will reset anytime the appliance main burner is used. Therefore, if the appliance is regularly used day to day, the pilot will remain on. However, this system does not require the user to remember to turn the pilot off as summer approaches and avoids unnecessary fuel consumption while still readily turned back on when the cold weather returns.

Your appliance may be equipped with an ACS or remote control device which enables you to select IPI or CPI modes.

If your appliance is equipped with an ACS switch, it has the option to change modes. If installed with the blue wire facing up, flipping the switch UP turns on the continuous pilot with timer and flipping the switch DOWN turns on the intermittent pilot ignition. If installed with the white wire facing up, the opposite is true.

If your appliance is equipped with a remote control device capable of selecting IPI / CPI modes, refer to remote operating instructions.

In order to start your pilot, turning the main burner on with the switch, remote or thermostat and then turning it off will reactivate the continuous pilot mode and reset the seven day timer.

For further information, refer to [www.napoleon.com/pilotondemand](http://www.napoleon.com/pilotondemand).



## ! WARNING

- If you do not follow these instructions exactly, a fire or explosion may result causing property damage, personal injury, or loss of life.
- If applicable, always light the pilot whether for the first time or if the gas supply has run out with the glass door opened or removed.

Ensure that a continuous gas flow is at the burner before installing the door. When lit for the first time, the appliance will emit an odor for a few hours. This is a normal temporary condition caused by the “burn-in” of paints and lubricants used in the manufacturing process and will not occur again. After extended periods of non-operation such as following a vacation or a warm weather season, the appliance may emit a slight odor for a few hours. This is caused by dust particles in the heat exchanger burning off. In both cases, open a window to sufficiently ventilate the room.

**For vent free appliances ONLY:** if the appliance shuts off, do not relight until you provide fresh air. If appliance keeps shutting off, have it serviced. Keep burner and control compartment clean.

### FOR YOUR SAFETY READ BEFORE LIGHTING

- Do not turn on if children or other at risk individuals are near the appliance.
- This appliance is equipped with a pilot which must be lit by hand while following these instructions exactly.
- Before operating, smell all around the appliance area for gas and next to the floor because some gas is heavier than air and will settle on the floor.
- Use only your hand to turn the gas control knob. Never use tools. If the knob will not turn by hand, do not try to repair it. Call a qualified service technician. Force or attempted repair may result in a fire or explosion.
- Do not use this appliance if any part has been under water. Immediately call a qualified service technician to inspect the appliance and replace any part of the control system and any gas control which has been underwater.





### WHAT TO DO IF YOU SMELL GAS

- Turn off all gas to the appliance.
- Open windows.
- Do not try to light any appliance.
- Do not touch any electric switch; do not use any phone in your building
- Immediately call your gas supplier from a neighbour's phone. Follow the gas supplier's instructions.
- If you cannot reach your gas supplier, call the fire department.

### LIGHTING INSTRUCTIONS

#### note:

When lighting and re-lighting, the gas knob cannot be turned from pilot to off unless the knob is depressed.

- Stop! Read the above safety information on this label.
- Remove batteries from the transmitter and set thermostat to lowest setting, if equipped.
- Turn off all electrical power to the appliance.
- Open the glass door, if equipped.
- Turn the gas knob clockwise  to the “OFF” position.
- Wait five (5) minutes to clear out any gas. If you smell gas including near the floor, STOP! Follow the instructions above in the “WHAT TO DO IF YOU SMELL GAS” section. If you don't smell gas; close the glass door and go to the next step.
- If the appliance is equipped with flame adjustment valve turn clockwise  to “OFF”.
- Turn gas knob counter-clockwise  to the “PILOT” position. (If the appliance is equipped with an “ON/OFF” switch, ensure it is in the “ON” position.
- Depress and hold gas knob while lighting the pilot with the push button ignitor. Keep knob fully depressed for one minute, then release. If pilot does not continue to burn, repeat steps E through I.
- With pilot lit, turn gas knob counter-clockwise  to the “ON” position.
- If equipped with the flame adjustment valve, push and turn the knob to high.
- Turn on all electrical power to the appliance and re-install the batteries into the transmitter, if equipped. Set thermostat to desired setting, if equipped.

### TO TURN OFF GAS

- Set thermostat to desired setting, if equipped.
- Turn off all electrical power to the appliance if service is to be performed.
- Push in gas knob slightly and turn clockwise  to the “OFF” position. Do not force.

# 11.0 adjustment

## 11.1 pilot burner adjustment

Adjust the pilot screw to provide properly sized flame. Turn in a clockwise direction to reduce the gas flow.

### Check Pressure Readings:

Inlet pressure can be checked by turning screw (A) counter-clockwise 2 or 3 turns and then placing pressure gauge tubing over the test point. Gauge should read as described on the chart below. Check pressure with main burner operating on "HI".

Outlet pressure can be checked the same as above using screw (B). Gauge should read as described on the chart below. Check pressure with main burner operating on "HI".

**After taking pressure readings, be sure to turn screws clockwise firmly to reseal. Do not overtorque.**

Leak test with a soap and water solution.

Prior to pilot adjustment, ensure that the pilot assembly has not been painted. If overspray or painting of the pilot assembly has occurred remove the paint from the pilot assembly, or replace. Fine emery cloth or a synthetic scrub pad (such as Scotch-Brite™) can be used to remove the paint from the pilot hood, electrode and flame sensor.

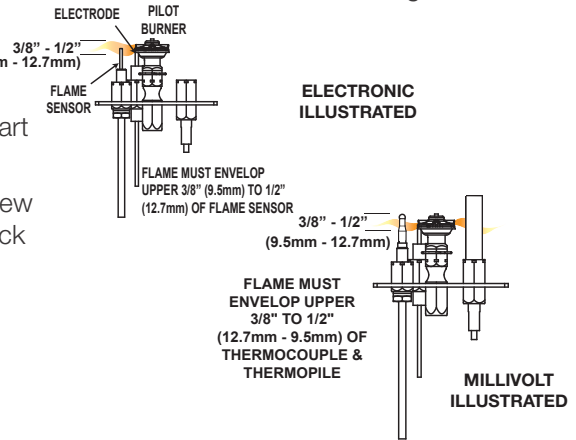

Pressure	Natural Gas (inches)	Natural Gas (millibars)	Propane (inches)	Propane (millibars)
Inlet	*7" (minimum 4.5")	17.4mb (minimum 11.2mb)	13" (minimum 11")	32.4mb (minimum 27.4mb)
Outlet	3.5"	8.7mb	10"	24.9mb

**\*Maximum inlet pressure not to exceed 13"**

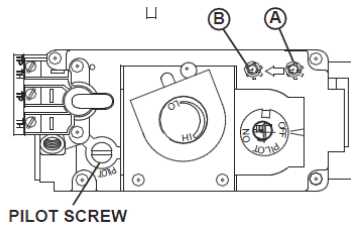

MILLIVOLT

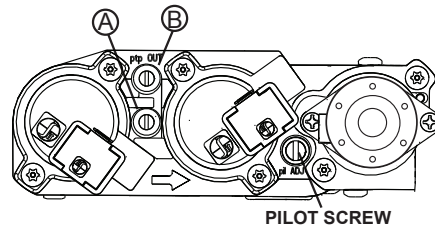

ELECTRONIC

### 11.2 venturi adjustment

This appliance has an air shutter that has been factory set open according to the chart below:

Regardless of venturi orientation, closing the air shutter will cause a more yellow flame, but can lead to carbonization. Opening the air shutter will cause a more blue flame, but can cause flame lifting from the burner ports. The flame may not appear yellow immediately; allow 15 to 30 minutes for the final flame colour to be established.

**AIR SHUTTER ADJUSTMENT MUST ONLY BE DONE BY A QUALIFIED INSTALLER.**

**note:**  
It is important that the orifice is securely inserted into the venturi.

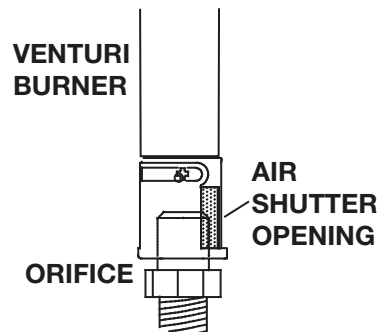

GDS28-1	
NG	3/8" (9.5mm)
P	5/16" (7.9mm)

### 11.3 flame characteristics

It's important to periodically perform a visual check of the pilot and burner flames. Compare them to the illustration provided. If any flames appear abnormal, call a service person.

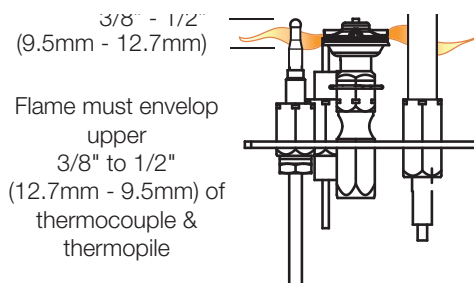
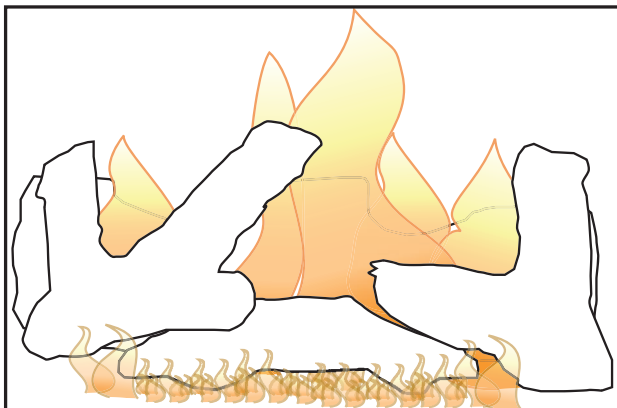

## 12.0 maintenance

### WARNING

- Turn off the gas and electrical power before servicing the appliance.
- Appliance may be hot. Do not service until appliance has cooled.
- Do not use abrasive cleaners on glass.
- Do not paint the pilot assembly.

This appliance and its venting system should be inspected before use and at least annually by a qualified service person. The following suggested checks should be performed by a qualified technician. The appliance area must be kept clear and free of combustible materials, gasoline, or other flammable vapors and liquids. The flow of combustion and ventilation air must not be obstructed.

#### note:

Caution: Label all wires prior to disconnection when servicing controls. Wiring errors can cause improper and dangerous operation. Verify proper operation after servicing.

1. In order to properly clean the burner and pilot assembly, remove the logs, rocks and/or glass to expose both assemblies.
2. Keep the control compartment, media, burner, air shutter opening and the area surrounding the appliance clean by vacuuming or brushing, at least once a year.
3. Check to see that all burner ports are burning. Clean out any of the ports which may not be burning or are not burning properly.
4. Check to see that the pilot flame is large enough to engulf the flame sensor and/or thermocouple / thermopile as well as it reaches the burner.
5. If your appliance is equipped with a safety barrier, cleaning may be necessary due to excessive lint / dust from carpeting, pets, etc. simply vacuum using the brush attachment.
6. If your appliance is equipped with relief doors, ensure the system performs effectively. Check that the gasket is not worn or damaged. Replace if necessary.
7. Replace the cleaned logs, rocks or glass. Failure to properly position the media may cause carboning which can be distributed in the surrounding living area, inside the firebox and on exterior surfaces surrounding vent termination.
8. Check to see that the main burner ignites completely on all ports when turned on. A 5 to 10 second total light-up period is satisfactory. If ignition takes longer, consult your local authorized dealer / distributor.
9. Visually inspect the appliance for carbon build up. Using a small whisk or brush, brush off the carbon and vacuum up or sweep into garbage.
10. **This step is not applicable for Vent Free appliances:** Check to see that the appliance is venting correctly. Ensure chimney system is safe and unobstructed. (If for any reason the vent air intake system is disassembled, re-install and re-seal per the instructions provided for the initial installation).

## 12.1 annual maintenance

### **WARNING**

- Annual maintenance should be performed by a qualified service technician
- The firebox becomes very hot during operation. Let the appliance cool completely or wear heat resistant gloves before conducting service.
- Never vacuum hot embers.
- Do not paint the pilot assembly

- This appliance will require maintenance which should be planned on an annual basis.
- Service should include cleaning, battery replacement, venting inspection and inspection of the burner, media, and firebox. Refer to the door removal section and remove the door as instructed.
- Carefully remove media if necessary (logs, glass, brick panels, etc.).
- Using a vacuum with soft brush attachment, gently remove any dirt, debris, or carbon build up from the logs, firebox, and burner. For glass media, follow the installation instructions for pre-cleaning.
- Gently remove any build-up on the pilot assembly including thermopile, thermocouple, flame sensor, and igniter (if equipped).

**note:**

Clean flame sensor using a fine emery cloth or a synthetic scrub pad (such as Scotch-Brite™) to remove any oxides. Clean the pilot assembly using a vacuum with a soft brush attachment. It is important that the pilot assembly is not painted.

- Inspect all accessible gaskets and replace as required.
- If equipped with a blower, access the blower and clean using a soft brush and vacuum.
- Re-assemble the various components in reverse order.
- Inspect the relief system. The appliance relieves through the main glass door or through the flaps on the firebox top. Ensure they open freely, and close sealed.
- Check the gas control valve pilot and Hi / Lo knobs move freely, if equipped. Replace if any stiffness in movement is experienced.
- Check for gas leaks on all gas connections up and downstream from the gas valve including pilot tube connections.

## 12.2 care of glass

### **WARNING**

- Do not clean glass when hot! Do not use abrasive cleaners to clean glass.

Buff lightly with a clean dry soft cloth to remove accumulated dust or fingerprints. Clean both sides of the glass after the first 10 hours of operation with an ammonia-free glass cleaner.

**note:**

Vinegar-based glass cleaners have demonstrated an ability to provide a clean, streak free glass surface.

Thereafter, clean as required. If the glass is not kept clean permanent discoloration and / or blemishes may result. Contact your local authorized dealer / distributor for complete cleaning instructions.

Razor blades, steel wool, or other metallic objects must not be used on both surfaces of the glass. Doing so can remove a thin layer of metal from the razor blades, steel wool, or other metallic objects that may then be deposited onto the coating. This can result in a discoloured stain or scratch-like mark. More importantly, this can scratch the glass surface, thereby reducing its strength.

Do not operate the appliance with broken glass, as leakage of flue gases may result.

Contact your local authorized dealer / distributor for complete cleaning instructions.

If the glass should ever crack or break while the fire is burning, do not open the door until the fire is out. Do not operate the appliance until the glass has been replaced. Contact you local authorized dealer / distributor for replacement parts. **DO NOT SUBSTITUTE MATERIALS.**

This appliance is factory equipped with 5mm ceramic glass. Use only replacement parts as supplied by the appliance manufacturer. **DO NOT SUBSTITUTE MATERIALS.**

# maintenance

## 12.3 blower replacement

Blower replacement may be done through either the firebox or from the rear of the appliance. Using the rear panel is recommended.

### INSTALLATION THROUGH THE REAR PANEL :

#### FOR MODEL GDS28

- Turn off the electrical power and the gas supply to the appliance.
- Remove the two combustion air covers and gaskets held on with 4 screws each. Remove the rear panel held in place with 6 screws.
- Remove the 2 screws holding the blower to its mounting plate. Disconnect the two blower wires.
- Replace the blower and reconnect the two wires. When replacing the rear panel, ensure that the wires are neither pinched nor interfere with the blower operation. Ensure that the combustion air cover plates and gaskets are properly installed and sealed.

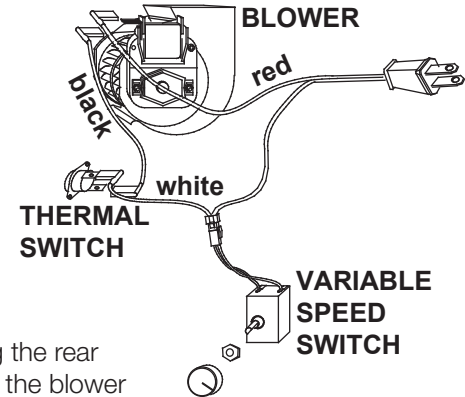

#### FOR MODEL GS28

- Turn off the electrical power and the gas supply to the appliance.
- Remove the 8 screws securing the air intake manifolds to the rear panel. Remove the rear panel held in place with 6 screws.
- Remove the 2 screws holding the blower to its mounting plate. Disconnect the two blower wires.
- Replace the blower and reconnect the two wires. When replacing the rear panel, ensure that the wires are neither pinched nor interfere with the blower operation. Re-secure the air intake manifolds.

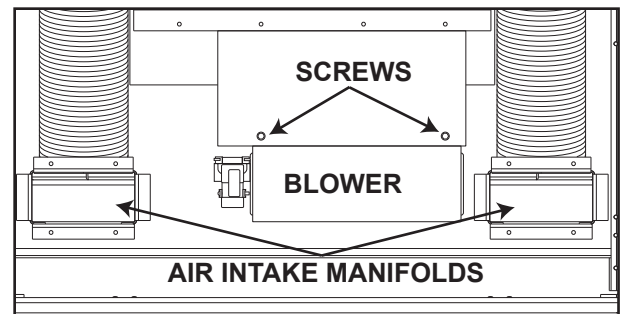

### INSTALLATION THROUGH THE FIREBOX:

#### REPLACEMENT BLOWER ACCESS GASKET IS REQUIRED.

- Turn off the electrical power and the gas supply to the appliance.
- Open the lower control door, the two side doors, and the fire viewing door. Remove the logs.
- Remove the blower access plate held on with 8 screws.
- Disconnect the two blower wires. Remove the blower bracket held on with 2 screws.
- Replace the blower using the existing bracket. Replace the bracket/blower assembly on the appliance.
- Reconnect the two wires. Hold the replacement gasket in place and reattach the blower access plate. Replace the logs. Close all doors.

Turn the gas supply and electricity back on.

Because the blower is thermally activated, when turned on, it will automatically start approximately 15-30 minutes after lighting the appliance and will run for approximately 30-45 minutes after the appliance has been turned off. Use of the fan increases the output of heat.

Drywall dust will penetrate into the blower bearings causing irreparable damage and must be prevented from coming into contact with the blower or its compartment.

Any damage resulting from this condition is not covered by the warranty policy.

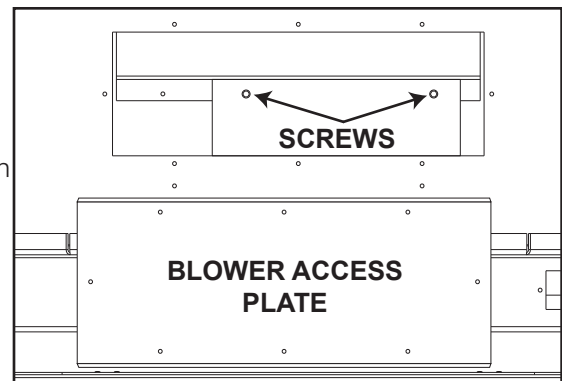



**! WARNING**

- Failure to position the parts in accordance with this manual or failure to use only parts specifically approved with this appliance may result in property damage or personal injury.

Contact your dealer for questions concerning prices and policies on replacement parts. Normally, all parts can be ordered through your Authorized dealer / distributor.

**For warranty replacement parts, a photocopy of the original invoice will be required to honour the claim.**

When ordering replacement parts always give the following information:

- Model & Serial Number of appliance
- Installation date of appliance
- Part number
- Description of part
- Finish

**Parts, part numbers, and availability are subject to change without notice.**

**Parts identified as stocked will be delivered within 2 to 5 business days for most delivery destinations.**

**Parts not identified as stocked will be delivered within a 2 to 4 week period, for most cases.**

**Parts identified as 'SO' are special order and can take up to 90 days for delivery.**

13.1 overview

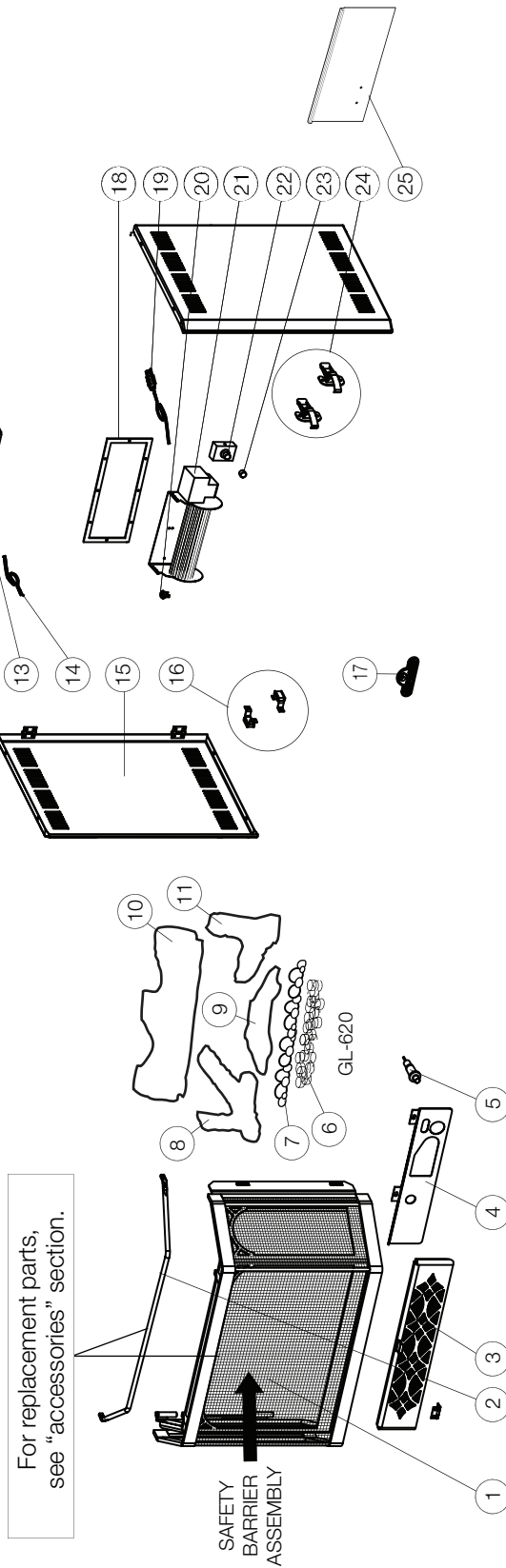

Items may not appear exactly as illustrated.

Ref. No.	Part number	Description	Stocked
1	W565-0195-SER	Safety barrier assembly	
2	W030-0022P	Accent bar access (BLACK)	
3	W010-2464	Control door assembly	
4	W475-0779-SER	Control panel (MV)	
4	W475-6215	Control panel (EI)	
5	W357-0001	Piezo ignitor (MV)	Yes
6	W361-0016	Glowing embers (GL-620)	Yes
7	W550-0001	Charcoal embers (GL-620)	Yes
8	W135-0061	Left side log (GL-620)	Yes
9	W135-0058	Front log (GL-620)	Yes
10	W715-0059	Rear log (GL-620)	Yes
11	W135-0060	Right side log (GL-620)	Yes
12	W010-2511	Trivet	
13	W660-0009	ON / OFF switch	Yes

Ref. No.	Part number	Description	Stocked
14	W750-0076	ON / OFF wires (38")	
15	W010-2514	Side door assembly (X2)	
16	W430-0002	Magnet door catch (X2)	
17	N385-0307	Napoleon logo	Yes
18	W290-0045	Blower access gasket	Yes
19	W750-0152	Power cord (7ft)	
20	W690-0002	Heat sensor	Yes
21	GZ552	Blower	Yes
22	KB-35	Variable speed switch (w/ knob)	Yes
23	W380-0002	Variable speed switch (knob only)	Yes
24	W390-0001	Door latch (X2)	
25	W500-1056	Control access cover	

13.2 millivolt valve train assembly

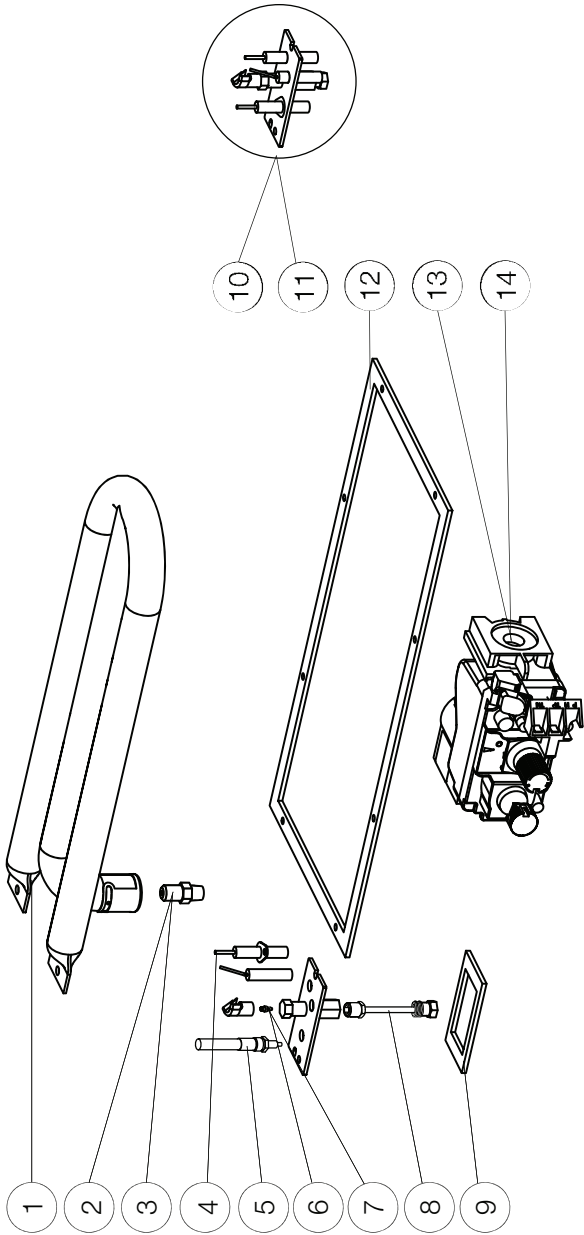

Items may not appear exactly as illustrated

Ref. No.	Part number	Description	Stocked
1	W100-0056	Main burner assembly	Yes
2	W456-0040	Burner orifice #40 (NG)	Yes
3	W456-0054	Burner orifice #54 (P)	Yes
4	W680-0008	Thermocouple	Yes
5	W680-0004	Thermopile	Yes
6	W455-0062	Pilot orifice (NG)	Yes
7	W455-0052	Pilot orifice (P)	Yes

Ref. No.	Part number	Description	Stocked
8	W720-0092	Pilot tube (w/ fittings)	Yes
9	W290-0029	Pilot gasket	Yes
10	W010-0633	Pilot assembly (NG) (w/ ignitor)	
11	W010-0550	Pilot assembly (P) (w/ ignitor)	
12	W290-0043	Burner gasket	
13	W725-0042	Valve (NG)	Yes
14	W725-0043	Valve (P)	Yes

13.3 electronic valve train assembly

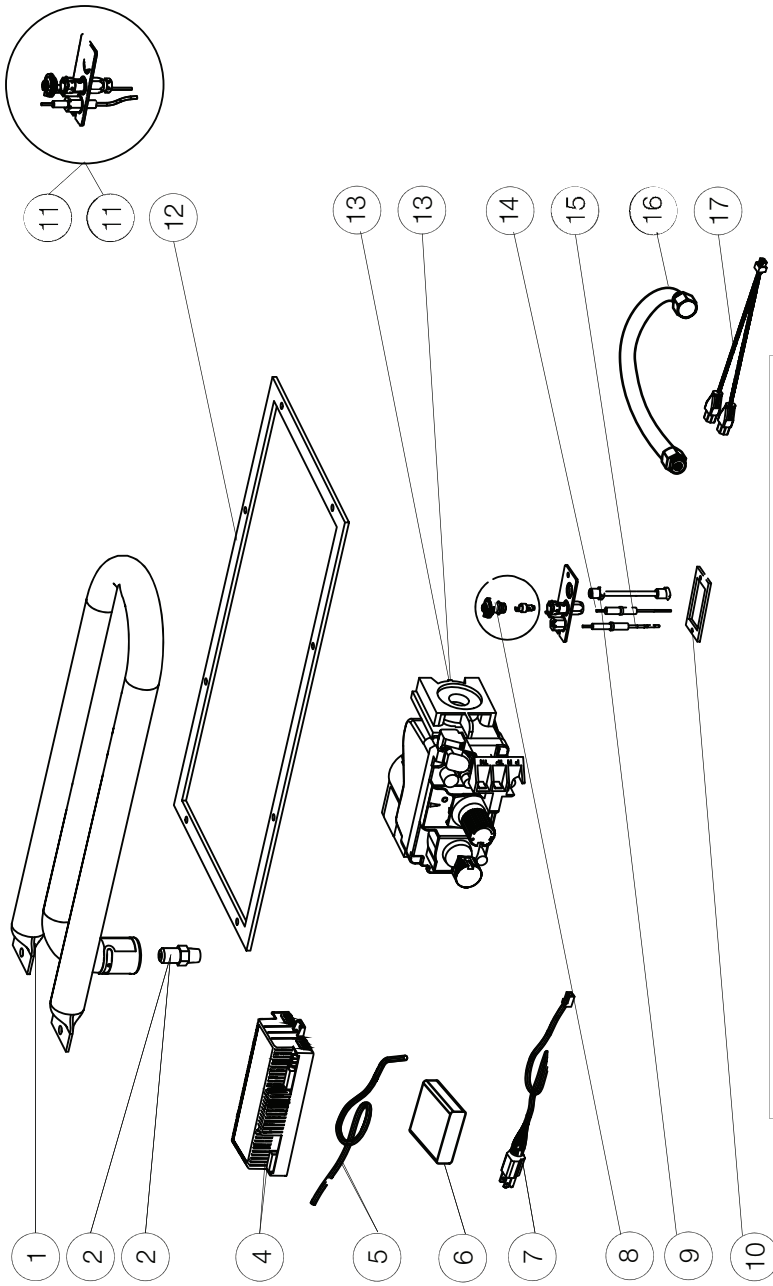

Items may not appear exactly as illustrated

Ref. No.	Part number	Description	Stocked
1	W100-0056	Main burner assembly	Yes
2	W456-0040	Burner orifice #40 (NG)	Yes
2	W456-0054	Burner orifice #54 (P)	Yes
3	W455-0070	Pilot orifice #62 (NG)	Yes
3	W455-0068	Pilot orifice #35 (P)	Yes
4	W190-0176	Control module	Yes
5	W750-0267	Wire harness (control)	Yes
6	W350-0702	Battery back-up	Yes
7	W750-0294	Power cord	
8	W335-0039	Pilot hood	

Ref. No.	Part number	Description	Stocked
9	W720-0092	Pilot tube (w/ fittings)	Yes
10	W290-0029	Pilot gasket	Yes
11	W010-2763	Pilot assembly (NG)	
11	W010-2808	Pilot assembly (P)	
12	W290-0043	Burner gasket	
13	W725-0062	Valve (NG)	Yes
13	W725-0063	Valve (P)	Yes
14	W240-0013	Electrode (w/ wire)	
15	W245-0025	Thermosensor	
16	W432-0077	Manifold flex pipe	
17	W175-0633	Connector	

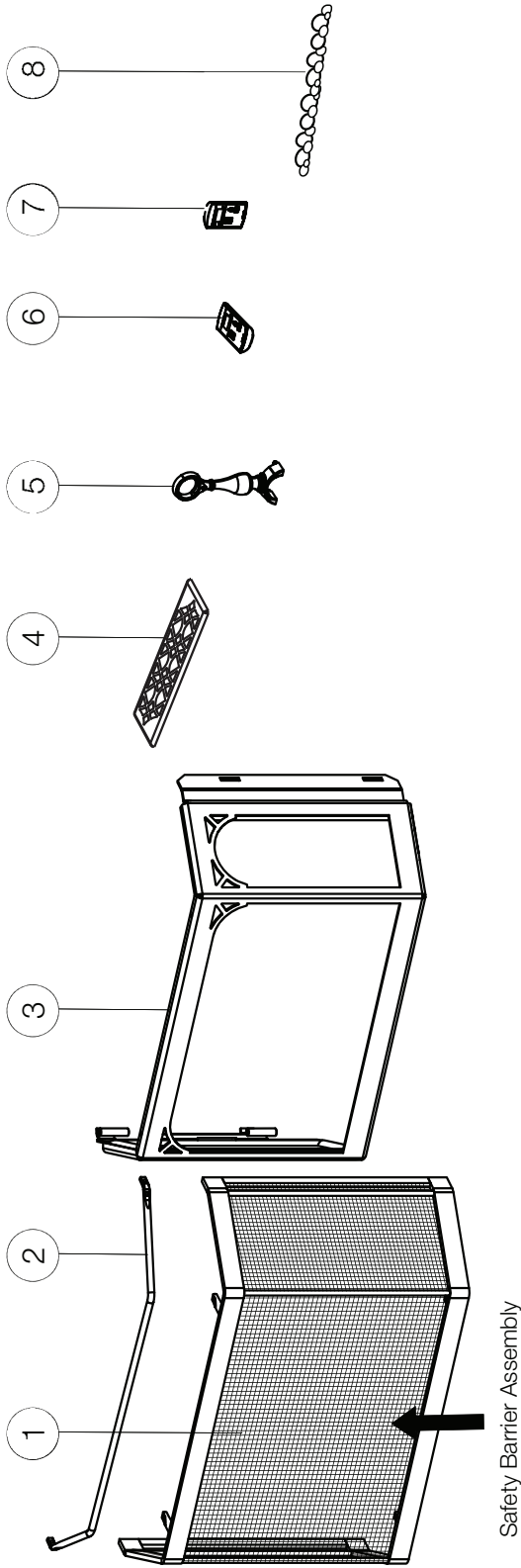

Safety Barrier Assembly

Items may not appear exactly as illustrated.

Ref. No.	Part number	Description	Stocked
1	W565-0195-SER	Safety barrier assembly	
2	AR28SS	Satin chrome plated accent bar	
3	GS328SSB	Satin chrome plated door	
3	GS328KSB	Metallic black door	
4	GS200-SS	Stain chrome plated ornamental trivet	
5	ANI-K	Black traditional andirons	
6	F45 / F60	Hand held remote control	
7	W660-0081	Wall mounted thermostat	
8	W361-0239-BULK	Ambient-glow embers	

# 15.0 troubleshooting (millivolt)

## ! WARNING

- Always light the pilot whether for the first time or if the gas supply has run out, with the glass door open or removed.
- Turn off gas and electrical power before servicing the appliance.
- Appliance may be hot. Do not service until appliance has cooled.
- Do not use abrasive cleaners

symptom	problem	test solution													
Main burner flame is a blue, lazy, transparent flame.	Blockage in vent.	- Remove blockage. In really cold conditions, ice buildup may occur on the terminal and should be removed as required. To minimize this from happening again, it is recommended that the vent lengths that pass through unheated spaces (attics, garages, crawl spaces) be wrapped with an insulated mylar sleeve. Prevent sleeve from sagging. Contact your local authorized dealer for more information.													
Main burner goes out; pilot stays on.	Pilot flame is not large enough or not engulfing the thermopile.	- Turn up the pilot flame. - Replace pilot assembly.													
	Thermopile shorting.	- Clean thermopile connection to the valve. Reconnect. - Replace thermopile / valve.													
	Remote wall switch wire is too long; too much resistance in the system.	- Shorten wire to correct length or wire gauge.													
	Faulty thermostat or switch.	- Replace.													
Main burner goes out; pilot goes out.	Refer to "MAIN BURNER GOES OUT; PILOT STAYS ON"														
	Vent is blocked	- Check for vent blockage.													
	Vent is re-circulating	- Check joint seals and installation													
	Flexible vent has become disconnected from appliance.	- Re-attach to appliance. - Cap was not replaced.													
Flames are consistently too large or too small. Carboning occurs.	Appliance is over-fired or under-fired.	- <b>Check pressure readings:</b> Inlet pressure can be checked by turning screw (A) counter-clockwise 2 or 3 turns and then placing pressure gauge tubing over the test point. Gauge should read as described on the chart below. Check that main burner is operating on 'HI'. Outlet pressure can be checked the same as above using screw (B). Gauge should read as described on the chart below. Check that main burner is operating on 'HI'. <b>AFTER TAKING PRESSURE READINGS, BE SURE TO TURN SCREWS CLOCKWISE FIRMLY TO RESEAL. DO NOT OVER TORQUE.</b> Leak test with a soap and water solution.													
		<table border="1"> <thead> <tr> <th>Pressure</th> <th>Natural Gas (inches)</th> <th>Natural Gas (millibars)</th> <th>Propane (inches)</th> <th>Propane (millibars)</th> </tr> </thead> <tbody> <tr> <td><b>Inlet</b></td> <td>* 13" (MIN. 4.5")</td> <td>17.4mb (MIN. 11.2mb)</td> <td>13" (MIN. 11")</td> <td>32.4mb (MIN. 27.4mb)</td> </tr> <tr> <td><b>Outlet</b></td> <td>3.5"</td> <td>8.7mb</td> <td>10"</td> <td>24.9mb</td> </tr> </tbody> </table>	Pressure	Natural Gas (inches)	Natural Gas (millibars)	Propane (inches)	Propane (millibars)	<b>Inlet</b>	* 13" (MIN. 4.5")	17.4mb (MIN. 11.2mb)	13" (MIN. 11")	32.4mb (MIN. 27.4mb)	<b>Outlet</b>	3.5"	8.7mb
Pressure	Natural Gas (inches)	Natural Gas (millibars)	Propane (inches)	Propane (millibars)											
<b>Inlet</b>	* 13" (MIN. 4.5")	17.4mb (MIN. 11.2mb)	13" (MIN. 11")	32.4mb (MIN. 27.4mb)											
<b>Outlet</b>	3.5"	8.7mb	10"	24.9mb											
	* Maximum inlet pressure not to exceed 13"														
	Air shutter improperly adjusted.	- Return air shutter to specified opening, see "venturi adjustment" section.													
Carbon is being deposited on glass, logs, rocks, media or combustion chamber surfaces.	Air shutter is blocked.	- Ensure air shutter opening is free of lint or other obstructions.													
	Flame is impinging on the glass, logs, rocks, media or combustion chamber.	- Ensure the media is positioned correctly in the appliance. - Open air shutter to increase the primary air. - Check the input rate: check the manifold pressure and orifice size as specified by the rating plate. - Ensure door gasketing is not broken or missing and the seal is tight. - Ensure vent liners are free of holes and well sealed at all joints. - Check that minimum rise per foot (meters) has been adhered to for any horizontal venting. - When heating with propane, ensure that the screen frame is secured as far to the back of the appliance as possible.													
White / grey film forms.	Sulphur from fuel is being deposited on glass, logs or combustion chamber surfaces.	- Clean the glass with a recommended gas fireplace glass cleaner. <b>DO NOT CLEAN GLASS WHEN HOT.</b> - If deposits are not cleaned off regularly, the glass may become permanently marked.													

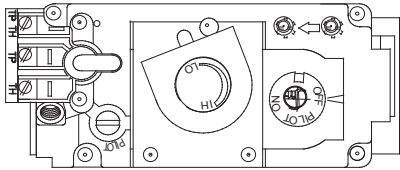

\* Maximum inlet pressure not to exceed 13"

Pressure	Natural Gas (inches)	Natural Gas (millibars)	Propane (inches)	Propane (millibars)
<b>Inlet</b>	* 13" (MIN. 4.5")	17.4mb (MIN. 11.2mb)	13" (MIN. 11")	32.4mb (MIN. 27.4mb)
<b>Outlet</b>	3.5"	8.7mb	10"	24.9mb

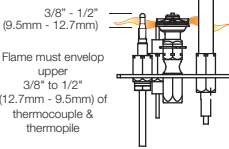
symptom	problem	test solution
Exhaust fumes smelled in room, headaches.	Appliance is spilling. (This is not applicable in outdoor appliances)	<ul style="list-style-type: none"> <li>- Check door seal.</li> <li>- Check for exhaust damage.</li> <li>- Check that venting is installed correctly.</li> <li>- Room is in negative pressure; increase fresh air supply.</li> </ul>
Exhaust fumes smelled in room, headaches.	Appliance is spilling. (This is not applicable in outdoor appliances)	<ul style="list-style-type: none"> <li>- Check door seal.</li> <li>- Check for exhaust damage.</li> <li>- Check that venting is installed correctly.</li> <li>- Room is in negative pressure; increase fresh air supply.</li> </ul>
Pilot will not light.	No spark at pilot burner.	<ul style="list-style-type: none"> <li>- Check if pilot can be lit by a match.</li> <li>- Check that the wire is connected to the push button ignitor.</li> <li>- Check if the push button ignitor needs tightening.</li> <li>- Replace the wire if the wire insulation is broken or frayed.</li> <li>- Replace the electrode if the ceramic insulator is cracked or broken.</li> <li>- Replace the push button ignitor</li> </ul>
	Out of propane gas.	<ul style="list-style-type: none"> <li>- Fill the tank.</li> </ul>
	Spark gap is incorrect.	<ul style="list-style-type: none"> <li>- Spark gap should be 0.150" (3.8mm) to 0.175" (4.5mm) from the electrode tip and the pilot burner. To ensure proper electrode location, tighten securing nut (finger tight plus 1/4 turn).</li> </ul>
	No gas at the pilot burner.	<ul style="list-style-type: none"> <li>- Check that the manual valve is turned on.</li> <li>- Check the pilot orifice for blockage.</li> <li>- Replace the valve.</li> <li>- Call the gas distributor.</li> </ul>
Pilot goes out when the gas knob is released.	System is not correctly purged	<ul style="list-style-type: none"> <li>- Purge the gas line.</li> </ul>
<b>The gas valve has an interlock device which will not allow the pilot burner to be lit until the thermocouple has cooled. Allow approximately 60 seconds for the thermocouple to cool.</b>	Out of propane gas.	<ul style="list-style-type: none"> <li>- Fill the tank.</li> </ul>
	Pilot flame is not large enough.	<ul style="list-style-type: none"> <li>- Turn up the pilot flame.</li> </ul>
	Pilot flame is not engulfing the thermocouple	<ul style="list-style-type: none"> <li>- Gently twist the pilot head to improve the flame pattern around the thermocouple.</li> </ul>
	Thermocouple shorting / faulty.	<ul style="list-style-type: none"> <li>- Loosen and tighten thermocouple.</li> <li>- Clean thermocouple and valve connection.</li> <li>- Replace thermocouple.</li> <li>- Replace valve.</li> </ul>
	Faulty valve.	<ul style="list-style-type: none"> <li>- Replace.</li> </ul>
Pilot burning; no gas to main burner; gas knob is on 'HI'; wall switch / thermostat is on.	Thermostat or switch is defective	<ul style="list-style-type: none"> <li>- Connect a jumper wire across the wall switch terminals; if main burner lights, replace switch / thermostat.</li> </ul>
	Wall switch wiring is defective.	<ul style="list-style-type: none"> <li>- Disconnect the switch wires &amp; connect a jumper wire across terminals 1 &amp; 3; if the main burner lights, check the wires for defects and/or replace wires.</li> </ul>
	Main burner orifice is plugged.	<ul style="list-style-type: none"> <li>- Remove stoppage in orifice.</li> </ul>
	Faulty valve.	<ul style="list-style-type: none"> <li>- Replace.</li> </ul>
Pilot goes out while standing; Main burner is in 'OFF' position.	Gas piping is undersized.	<ul style="list-style-type: none"> <li>- Turn on all gas appliances and see if pilot flame flutters, diminishes or extinguishes, especially when main burner ignites. Monitor appliance supply working pressure.</li> <li>- Check if supply piping size is to code. Correct all undersized piping.</li> </ul>
Flames are very aggressive.	Door is ajar.	<ul style="list-style-type: none"> <li>- Ensure the mechanical means of securing the door is providing a tight seal.</li> </ul>
	Venting action is too great.	<ul style="list-style-type: none"> <li>- Check to ensure venting is properly sealed.</li> <li>- If restriction is required see "restricting vertical vents" section.</li> </ul>
Remote wall switch is in 'OFF' position; main burner comes on when gas knob is turned to 'ON' position.	Wall switch is mounted upside down.	<ul style="list-style-type: none"> <li>- Reverse.</li> </ul>
	Remote wall switch is grounding.	<ul style="list-style-type: none"> <li>- Replace.</li> </ul>
	Remote wall switch wire is grounding.	<ul style="list-style-type: none"> <li>- Check for ground (short); repair ground or replace wire.</li> </ul>
	Faulty valve.	<ul style="list-style-type: none"> <li>- Replace.</li> </ul>

## troubleshooting (millivolt)

symptom	problem	test solution
Door Sticking	Dirt / dust adheres to the hinges; is heated and burns causing sticking.	<ul style="list-style-type: none"> <li>- Lift door from its hinges. Lubricate with high temp dry graphite only. Replace.</li> <li>- <b>NOTE:</b> Due to the high temperatures that the hinges experience, wet lubricants such as oil and WD40 will cause the hinge to seize and are therefore not suitable.</li> </ul>
Main burner goes out; pilot goes out.	Thermocouple shorting or faulty.	<ul style="list-style-type: none"> <li>- Loosen and tighten thermocouple.</li> <li>- Clean thermocouple and valve connection.</li> <li>- Replace thermocouple.</li> </ul>
<b>GS28</b>		
Main burner goes out; pilot stays on.	Venting is spilling.	<ul style="list-style-type: none"> <li>- Test with spill switch bypassed.</li> <li>- Check for vent blockage.</li> </ul>
<b>GDS28</b>		
Main burner goes out; pilot goes out.	Vent re-circulating.	<ul style="list-style-type: none"> <li>- Check joint seals and installation.</li> </ul>
Main burner flame is a blue, lazy, transparent flame.	Blockage in vent.	<ul style="list-style-type: none"> <li>- Remove blockage. In really cold conditions, ice buildup may occur on the terminal and should be removed as required.</li> </ul>
	Incorrect installation.	<ul style="list-style-type: none"> <li>- Ensure vent configuration is within prescribed venting parameters</li> </ul>



## **! WARNING**

- Always light the pilot whether for the first time or if the gas supply has run out, with the glass door open or removed.
- Turn off gas and electrical power before servicing the appliance.
- Appliance may be hot. Do not service until appliance has cooled.
- Do not use abrasive cleaners

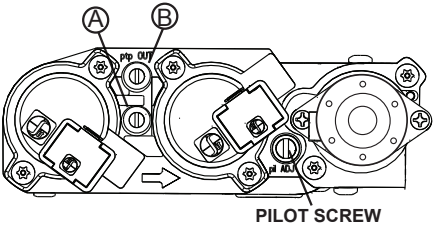
symptom	problem	test solution															
Main burner flame is a blue, lazy, transparent flame.  (This is not applicable in outdoor appliances)	Blockage in vent.	- Remove blockage. In really cold conditions, ice buildup may occur on the terminal and should be removed as required. (To minimize this from reoccurring, the vent lengths that pass through unheated spaces (attics, garages, crawl spaces) should be wrapped with an insulated mylar sleeve).															
	Incorrect installation.	- Refer to “venting” section to ensure correct installation.															
Flames are consistently too large or too small. Carboning occurs.	Appliance is over-fired or under-fired.	- <b>Check pressure readings:</b> Inlet pressure can be checked by turning screw (A) counter-clockwise 2 or 3 turns and then placing pressure gauge tubing over the test point. Gauge should read as described on the chart below. Check that main burner is operating on ‘HI’. Outlet pressure can be checked the same as above using screw (B). Gauge should read as described on the chart below. Check that main burner is operating on ‘HI’. <b>After taking pressure readings, be sure to turn screws clockwise firmly to reseal. DO NOT OVER TORQUE.</b> Leak test with a soap and water solution.															
																	
		<table border="1"> <thead> <tr> <th>Pressure</th> <th>Natural Gas (inches)</th> <th>Natural Gas (millibars)</th> <th>Propane (inches)</th> <th>Propane (millibars)</th> </tr> </thead> <tbody> <tr> <td><b>Inlet</b></td> <td>*7” (minimum 4.5”)</td> <td>17.4mb (minimum 11.2mb)</td> <td>13” (minimum 11”)</td> <td>32.4mb (minimum 27.4mb)</td> </tr> <tr> <td><b>Outlet</b></td> <td>3.5”</td> <td>8.7mb</td> <td>10”</td> <td>24.9mb</td> </tr> </tbody> </table> <p style="text-align: center;"><b>*Maximum inlet pressure not to exceed 13” w.c.</b></p>	Pressure	Natural Gas (inches)	Natural Gas (millibars)	Propane (inches)	Propane (millibars)	<b>Inlet</b>	*7” (minimum 4.5”)	17.4mb (minimum 11.2mb)	13” (minimum 11”)	32.4mb (minimum 27.4mb)	<b>Outlet</b>	3.5”	8.7mb	10”	24.9mb
Pressure	Natural Gas (inches)	Natural Gas (millibars)	Propane (inches)	Propane (millibars)													
<b>Inlet</b>	*7” (minimum 4.5”)	17.4mb (minimum 11.2mb)	13” (minimum 11”)	32.4mb (minimum 27.4mb)													
<b>Outlet</b>	3.5”	8.7mb	10”	24.9mb													
	Air shutter improperly adjusted.	- Return air shutter to specified opening, see “venturi adjustments” section in the installation manual.															
Carbon is being deposited on glass, logs, rocks, media, or combustion chamber surfaces.	Air shutter is blocked.	- Ensure air shutter opening is free of lint or other obstructions.															
	Flame is impinging on the glass, logs, rocks, media or combustion chamber.	- Ensure the media is positioned correctly in the appliance. - Open air shutter to increase the primary air. - Check the input rate: check the manifold pressure and orifice size as specified by the rating plate. - Ensure door gaskets are not broken or missing and the seal is tight. - Ensure vent liners are free of holes and well sealed at all joints. - Check that minimum rise per foot (meters) has been adhered to for any horizontal venting.															
White / grey film forms.	Sulphur from fuel is being deposited on glass, logs, or combustion chamber surfaces.	- Clean the glass with a recommended gas fireplace glass cleaner. <b>DO NOT CLEAN GLASS WHEN HOT.</b> - If deposits are not cleaned off regularly, the glass may become permanently marked.															
Exhaust fumes smelled in room, headaches. (This is not applicable in outdoor appliances).	Appliance is spilling. (This is not applicable in outdoor appliances).	- Check door seal. - Check for exhaust damage. - Check that venting is installed correctly. - Room is in negative pressure; increase fresh air supply.															

# troubleshooting (electronic)

symptom	problem	test solution
Pilot will not light. Makes noise with no spark at pilot burner.	Wiring: short, loose, or damaged connections (poor flame rectification).	<ul style="list-style-type: none"> <li>- Verify the thermocouple/sensor is clean and the wiring is undamaged.</li> <li>- Verify the interrupter block is not damaged or too tight. Verify connections from pilot assembly are tight; also verify the connections are not grounding out to any metal. (Remember, the flame carries the rectification current, not the gas. If flame lifts from pilot hood, the circuit is broken. A wrong orifice or too high of an inlet pressure can cause the pilot flame to lift)*. The sensor rod may need cleaning.</li> </ul>
	No signal from remote with no pilot ignition.	<ul style="list-style-type: none"> <li>- Reprogram receiver code.</li> <li>- Replace receiver.</li> </ul>
	Poor grounding.	<ul style="list-style-type: none"> <li>- Verify the valve / pilot assembly are properly grounded</li> </ul>
	Improper switch wiring.	<ul style="list-style-type: none"> <li>- Troubleshoot the system with the simplest <b>on/off</b> switch.</li> </ul>
	Dirty, painted, or damaged pilot and/or dirty sensor rod.	<ul style="list-style-type: none"> <li>- Clean sensor rod with a green Scotch-Brite™ pad to remove any contamination that may have accumulated. Verify continuity with multimeter with ohms set at the lowest range.</li> </ul>
Pilot sparks but will not light.	Gas supply.	<ul style="list-style-type: none"> <li>- Verify that the incoming gas line ball valve is “open”.</li> <li>- Verify that the inlet pressure reading is within acceptable limits, inlet pressures must not exceed 13” W.C. (32.4mb).</li> </ul>
	Out of propane gas.	<ul style="list-style-type: none"> <li>- Fill the tank.</li> </ul>
	Pilot supply line may contain air.	<ul style="list-style-type: none"> <li>- Repeat ignition process several times or purge the pilot supply line.</li> </ul>
	Incorrect wiring / grounding.	<ul style="list-style-type: none"> <li>- Ensure correct polarity of wiring of thermocouple (if equipped).</li> <li>- Verify pilot assembly / valve are properly grounded.</li> </ul>
	Receiver (if equipped).	<ul style="list-style-type: none"> <li>- Reset program: hold reset button on receiver and wait for 2 beeps. Release after second beep. Press small flame button on remote within 20 seconds, you will hear an additional beep (this signals a successful reset).</li> <li>- Replace receiver.</li> </ul>
	Valve.	<ul style="list-style-type: none"> <li>- Check valve and replace if necessary (Do not to overtighten thermocouple).</li> </ul>
Burner continues to spark and pilot lights but main burner does not light.	Short or loose connection in sensor rod.	<ul style="list-style-type: none"> <li>- Verify all connections. Verify the connections from the pilot assembly are tight. Also, verify these connections are not grounding out to any metal.</li> </ul>
	Dirty, painted, or damaged pilot assembly components.	<ul style="list-style-type: none"> <li>- Clean using a green Scotch-Brite™ pad to remove any contamination that may have accumulated on the sensor rod, pilot hood, ignitor, or flame sensor. Verify continuity with multimeter with ohms set at the lowest range.</li> </ul>
Remote wall switch is in “ <b>off</b> ” position; burner comes on.	Wall switch mounted upside down.	<ul style="list-style-type: none"> <li>- Reverse.</li> </ul>
	Remote wall switch and/or wire is grounding.	<ul style="list-style-type: none"> <li>- Replace.</li> <li>- Check for ground (short); repair ground or replace wire.</li> </ul>
	Faulty wire	<ul style="list-style-type: none"> <li>- Replace.</li> </ul>
Remote and / or receiver is not functioning properly.	Remote controls lights but no spark or flame. (Remote is locked out).	<ul style="list-style-type: none"> <li>- Reset by turning power source off then on.</li> </ul> <div style="border: 1px solid black; padding: 2px; margin-top: 5px;"> <p><b>note:</b> If back up batteries are installed, they must also be removed to re-program</p> </div>
	Receiver or remote has low battery.	<ul style="list-style-type: none"> <li>- Replace batteries.</li> </ul>
	Appliance functions but does not respond to receiver / remote	<ul style="list-style-type: none"> <li>- Ensure appliance is being operated by the same device that turned it on. Remote controls function if appliance was turned on by remote. Receiver controls function if appliance was turned on by receiver.</li> </ul>
	Error with synchronizing.	<ul style="list-style-type: none"> <li>- Reset receiver and remote.</li> </ul>
	Remote too far away from receiver.	<ul style="list-style-type: none"> <li>- Refer to “wiring diagram” section.</li> </ul>
	Wire connector pins are bent.	<ul style="list-style-type: none"> <li>- Straighten pins.</li> </ul>
	Valve wiring is damaged.	<ul style="list-style-type: none"> <li>- Replace valve.</li> </ul>

symptom	problem	test solution
Lights or blower won't function (if equipped).	Control module switch in wrong position.	- Verify ON/OFF switch is in the "I" position which denotes on.
	COM switch is unplugged.	- Verify "COM" switch is plugged into the front of the control module.
Flames are very aggressive.	Door is ajar.	- Ensure door is secured properly.
	Venting action is too great.	- Check to ensure venting is properly sealed or restrict vent exit with restrictor plate. (Not available in all appliances).
Appliance won't perform any functions.	No power to the system.	- Check breaker to verify it's in the "on" position.
	Receiver switch in wrong position (if equipped).	- Verify that the 3 position switch on the receiver is in the remote position (middle).
	Transmitter isn't operational.	- Check battery power and battery orientation.

**The following applies specifically to the SIT system only:**

<p>Pilot will not light. Makes no noise with no spark at pilot burner. (Lights and blower operate, if equipped).</p>	<p>Ignition box has been locked out.</p>	<p>Choose one of the 3 methods below to reset the system.</p> <ol style="list-style-type: none"> <li>1. To reset ignition box when locked out. Turn off power supply and remove batteries (if used) from the back up battery pack.</li> <li>2. To reset the DFC Board when the board goes into a lock out condition and the LED is blinking 3 times using the transmitter <b>on/off</b> button:                             <ul style="list-style-type: none"> <li><b>Step 1:</b> Turn the system off by pressing the <b>on/off</b> button to turn the system off.</li> <li><b>Step 2:</b> After approximately 2 seconds press the <b>on/off</b> button on the transmitter again. The DFC Board will reset and the ignition sequence will start again.</li> </ul> </li> <li>3. To reset the DFC Board when the board goes into a lock out condition and the LED is blinking 3 times by cycling flame:                             <ul style="list-style-type: none"> <li><b>Step 1:</b> In the manual flame control mode, use the down arrow button to reduce the flame to off, indicated by the word OFF displayed on the transmitter LCD screen.</li> <li><b>Step 2:</b> Wait approximately 2 seconds and press the up arrow button, the ignition sequence will start.</li> </ul> </li> </ol>
--	--	---

**note:**

Starting from **off**, press the **on** button on the transmitter. After approximately 4 seconds **on/off** button is pressed, the ignition board will start the spark. The attempt for ignition will last approximately 60 seconds. If there is no flame ignition (rectification), the board will stop sparking and the board will go into lock out.

## 17.0 warranty

Napoleon products are manufactured under the strict Standard of the world recognized ISO 9001 : 2015 Quality Management System.

Napoleon products are designed with superior components and materials assembled by trained craftsmen who take great pride in their work. The burner and valve assembly are leak and test-fired at a quality test station. The complete appliance is again thoroughly inspected by a qualified technician before packaging to ensure that you, the customer, receive the quality product that you expect from Napoleon.

### Napoleon Gas Appliance President's Lifetime Limited Warranty

The following materials and workmanship in your new Napoleon gas appliance are warranted against defects for as long as you own the appliance. This covers: combustion chamber, heat exchanger, stainless / steel burner, Phazer™ logs and embers, rocks, ceramic glass (thermal breakage only), gold plated parts against tarnishing, porcelainized enameled components and aluminum extrusion trims.\*

Electrical (110V and millivolt) components and wearable parts are covered and Napoleon will provide replacement parts free of charge during the first year of the limited warranty. This covers: blowers, gas valves, thermal switches, switches, wiring, remote controls, ignitors, gaskets and pilot assemblies.\*

Labour related to warranty repair is covered free of charge during the first year (labour warranty is not applicable for the Gas Log Sets). Repair work, however, requires the prior approval of an authorized company official. Labour costs to the account of Napoleon are based on a predetermined rate schedule and any repair work must be done through an authorized Napoleon dealer.

\* Construction of models vary. Warranty applies only to components included with your specific appliance.

### Conditions and Limitations

Napoleon warrants its products against manufacturing defects to the original purchaser only. Registering your warranty is not necessary. Simply provide your proof of purchase along with the model and serial number to make a warranty claim. Napoleon reserves the right to have its representative inspect any product or part thereof prior to honouring any warranty claim. Provided that the purchase was made through an authorized Napoleon dealer your appliance is subject to the following conditions and limitations:

Warranty coverage begins on the date of original installation. This factory warranty is non-transferable and may not be extended whatsoever by any of our representatives. The gas appliance must be installed by a licensed, authorized service technician or contractor qualified and authorized installer, service agency or supplier. Installation must be done in accordance with the installation instructions included with the product and all local and national building and fire codes. This limited warranty does not cover damages caused by misuse, lack of maintenance, accident, alterations, abuse or neglect, and parts installed from other manufacturers will nullify this warranty. This limited warranty further does not cover any scratches, dents, corrosion or discoloring caused by excessive heat, abrasive and chemical cleaners nor chipping on porcelain enamel parts, mechanical breakage of Phazer™ logs and embers. This warranty extends to the repair or replacement of warranted parts which are defective in material or workmanship provided that the product has been operated in accordance with the operation instructions and under normal conditions. After the first year, with respect to this President's Lifetime Limited Warranty, Napoleon may, at its discretion, fully discharge all obligations with respect to this warranty by refunding to the original warranted purchaser the wholesale price of any warranted but defective part(s).

After the first year, Napoleon will not be responsible for installation, labour, or any other expenses related to the reinstallation of a warranted part and such expenses are not covered by this warranty. Notwithstanding any provisions contained in the President's Lifetime Limited Warranty, Napoleon's responsibility under this warranty is defined as above and it shall not in any event extend to any incidental, consequential or indirect damages. This warranty defines the obligations and liability of Napoleon with respect to the Napoleon gas appliance and any other warranties expressed or implied with respect to this product, its components or accessories are excluded. Napoleon neither assumes, nor authorizes any third party to assume, on its behalf, any other liabilities with respect to the sale of this product. Napoleon will not be responsible for: over-firing, downdrafts, spillage caused by environmental conditions such as rooftops, buildings, nearby trees, hills, mountains, inadequate vents or ventilation, excessive venting configurations, insufficient makeup air, or negative air pressures which may or may not be caused by mechanical systems such as exhaust fans, furnaces, clothes dryers, etc. Any damages to the appliance, combustion chamber, heat exchanger, plated trim or other components due to water, weather damage, long periods of dampness, condensation, damaging chemicals or cleaners will not be the responsibility of Napoleon.

During the first 10 years Napoleon will replace or repair the defective parts covered by the lifetime warranty at our discretion free of charge. From 10 years to life, Napoleon will provide replacement parts at 50% of the current retail price. The manufacturer may require that defective parts or products be returned or that digital pictures be provided to support the claim. Returned products are to be shipped prepaid to the manufacturer for investigation. If a product is found to be defective, the manufacturer will repair or replace such defect. Before shipping your appliance or defective components, your dealer must obtain an authorization number. Any merchandise shipped without authorization will be refused and returned to sender. Shipping costs are not covered under this warranty. Additional service fees may apply if you are seeking warranty service from a dealer. Warranty labour allowance is only for the replacement of the warranted part. Travel, diagnostic tests, shipping and other related charges are not covered by this warranty.



# NAPOLEON CELEBRATING OVER 40 YEARS OF HOME COMFORT PRODUCTS



7200, Route Transcanadienne, Montréal, Québec H4T 1A3  
24 Napoleon Road, Barrie, Ontario, Canada L4M 0G8  
214 Bayview Drive, Barrie, Ontario, Canada L4N 4Y8  
103 Miller Drive, Crittenden, Kentucky, USA 41030  
De Riemsdijk 22, 4004 LC Tiel, The Netherlands

Phone: 1-866-820-8686  
[napoleon.com](http://napoleon.com)