



INSTALLATION MANUAL

Luxuria™ Series (LVX38-1 illustrated)

SAFETY INFORMATION

! WARNING

FIRE OR EXPLOSION HAZARD

Failure to follow safety warnings exactly could result in serious injury, death, or property damage.

- Do not store or use gasoline or other flammable vapors and liquids in the vicinity of this or any other appliance.

- WHAT TO DO IF YOU SMELL GAS:

- Do not try to light any appliance.
- Do not touch any electrical switch; do not use any phone in your building.
- Immediately call your gas supplier from a neighbour's phone. Follow the gas supplier's instructions.
- If you cannot reach your gas supplier, call the fire department.

- Installation and service must be performed by a qualified installer, service agency, or the supplier.

This appliance may be installed in an aftermarket, permanently located, manufactured home (USA only) or mobile home, where not prohibited by local codes.

This appliance is only for use with the type of gas indicated on the rating plate. This appliance is not convertible for use with other gases, unless a certified kit is used.

INSTALLER:

Leave this manual with the appliance

CONSUMER:

Retain this manual for future reference

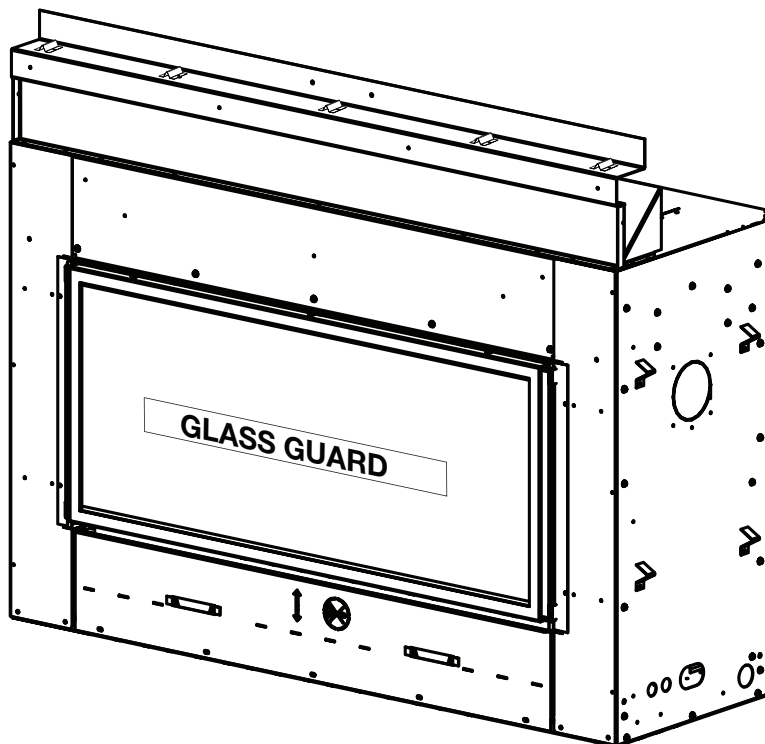

THIS APPLIANCE IS INSTALLED WITH



FOR INDOOR USE ONLY

CERTIFIED TO THE CANADIAN AND AMERICAN NATIONAL STANDARDS:
CSA 2.22 AND ANSI Z21.50 FOR VENTED DECORATIVE GAS APPLIANCES



PLACE BARCODE LABEL ON THE OWNER'S MANUAL

Wolf Steel Ltd., 24 Napoleon Rd., Barrie, ON, L4M 0G8 Canada / 103 Miller Drive, Crittenden, Kentucky, USA, 41030
Phone 1 (866) 820-8686 • www.napoleon.com • hearth@napoleon.com

safety information

WARNING

- **This appliance is hot when operated and can cause severe burns if contacted.**
- **Any changes or alterations to this appliance or its controls can be dangerous and is prohibited.**
- Do not operate appliance before reading and understanding operating instructions. Failure to operate appliance according to operating instructions could cause fire or injury.
- Ensure the glass door is opened or removed when lighting the pilot for the first time and when the gas supply has run out.
- Risk of fire or asphyxiation, do not operate appliance with fixed glass removed and never obstruct the front opening of the appliance.
- Do not connect 110 volts to the control valve, with the exception of models; GSST8 and GT8.
- Risk of burns. The appliance should be turned off and cooled before servicing.
- Do not install damaged, incomplete or substitute components.
- Risk of cuts and abrasions. Wear protective gloves, protective footwear, and safety glasses during installation. Sheet metal edges may be sharp.
- Do not burn wood or other materials in this appliance.
- Provide adequate ventilation and combustion air. Provide adequate accessibility clearance for servicing and operating the appliance.
- High pressure will damage valve. Disconnect gas supply piping before pressure testing gas line at test pressures above 1/2 psig. Close the manual shut-off valve before pressure testing gas line at test pressures equal to or less than 1/2 psig (35mb).
- The appliance must not be operated at temperatures below freezing (32°F / 0°C). Allow the appliance to warm to above freezing prior to operation, with the exception of models; GSS36, GSS42; these appliances are suitable for 0°F / -18°C.
- **Children and adults should be alerted to hazards of high surface temperature and should stay away to avoid burns or clothing ignition.**
- **Young children should be carefully supervised when they are in the same room as the appliance. Toddlers, young children and others may be susceptible to accidental contact burns. A physical barrier is recommended if there are at risk individuals in the house. To restrict access to an appliance or stove, install an adjustable safety gate to keep toddlers, young children and other at risk individuals out of the room and away from hot surfaces.**
- **Clothing or other flammable material should not be placed on or near the appliance.**
- **Due to high temperatures, the appliance should be located out of traffic and away from furniture and draperies.**
- Furniture or other objects must be kept a minimum of 4 feet (1.22m) away from the front of the appliance.
- Ensure you have incorporated adequate safety measure to protect infants/toddlers from touching hot surfaces.
- Even after the appliance is off, it will remain hot for an extended period of time.
- Check with your local hearth specialty dealer for safety screens and hearth guards to protect children from hot surfaces. These screens and guards must be fastened to the floor.
- **Any safety screen, guard or barrier removed for servicing the appliance, must be replaced prior to operating the appliance.**
- It is imperative that the control compartments, burners and circulating blower and its passageway in the appliance and venting system are kept clean. The appliance and its venting system should be inspected before use and at least annually by a qualified service person. More frequent cleaning may be required due to excessive lint from carpeting, bedding material, etc. The appliance area must be kept clear and free from combustible materials, gasoline and other flammable vapors and liquids.
- If the appliance shuts off, do not re-light until you provide fresh air. If appliance keeps shutting off, have it serviced. Keep burner and control compartment clean.
- Under no circumstances should this appliance be modified.
- Do not allow wind or fans to blow directly into the appliance. Avoid any drafts that alter burner flame patterns.



DANGER



HOT GLASS WILL CAUSE BURNS.

DO NOT TOUCH GLASS UNTIL COOLED.

NEVER ALLOW CHILDREN TO TOUCH GLASS.

A barrier designed to reduce the risk of burns from the hot viewing glass is provided with this appliance and must be installed for the protection of children and other at-risk individuals.

! WARNING

- Do not use a blower insert, heat exchanger insert or other accessory not approved for use with this appliance.
- This appliance must not be connected to a chimney flue pipe serving a separate solid fuel burning appliance.
- Do not use this appliance if any part has been under water. Immediately call a qualified service technician to inspect the appliance and to replace any part of the control system and any gas control which has been under water.
- Do not operate the appliance with the glass door removed, cracked or broken. Replacement of the glass should be done by a licensed or qualified service person, if equipped.
- Do not strike or slam shut the appliance glass door, if equipped.
- **Only doors / optional fronts certified with the appliance are to be installed on the appliance.**
- Keep the packaging material out of reach of children and dispose of the material in a safe manner. As with all plastic bags, these are not toys and should be kept away from children and infants.
- Carbon or soot should not occur in a vent free appliance as it can distribute into the living area of your home. If you notice any signs of carbon or soot, immediately turn off your appliance and arrange to have it serviced by a qualified technician before operating it again.
- If equipped, the screen must be in place (closed) when the appliance is in operation.
- When equipped with pressure relief doors, they must be kept closed while the appliance is operating to prevent exhaust fumes containing carbon monoxide, from entering into the home. Temperatures of the exhaust escaping through these openings can also cause the surrounding combustible materials to overheat and catch fire.
- Carbon monoxide poisoning may lead to death; early signs of carbon monoxide poisoning resemble the flu, with headache, dizziness and/or nausea. If you have these signs, the appliance may not be working properly. Get fresh air at once! Have appliance serviced. Some people; pregnant women, persons with heart or lung disease, anemia, those under the influence of alcohol, those at high altitudes are more affected by carbon monoxide than others. Failure to keep the primary air opening(s) of the burner(s) clean may result in sooting and property damage.
- As with any combustion appliance, we recommend having your appliance regularly inspected and serviced as well as having a Carbon Monoxide Detector installed in the same area to defend you and your family against Carbon Monoxide (not applicable for outdoor appliances).
- Ensure clearances to combustibles are maintained when building a mantel or shelves above the appliance. Elevated temperatures on the wall or in the air above the appliance can cause melting, discolouration or damage to decorations, a TV or other electronic components.
- **For appliances equipped with a safety barrier; if the barrier becomes damaged, the barrier shall be replaced with the manufacturer's barrier for this appliance.**
- **Installation and repair should be done by a qualified service person. It is imperative that control compartments, burners and circulating air passageways of the appliance be kept clean.**
- For outdoor products only: this appliance must not be installed indoors or within any structure that prevents or inhibits the exhaust gases from dissipating in the outside atmosphere.
- If applicable, the millivolt version of this appliance uses and requires a fast acting thermocouple. Replace only with a fast acting thermocouple supplied by Wolf Steel Ltd.

! WARNING: This product can expose you to chemicals including lead and lead compounds, which are known to the State of California to cause cancer, and chemicals including carbon monoxide, which are known to the State of California to cause birth defects or other reproductive harm. For more information, go to www.P65Warnings.ca.gov.

! WARNING !

FIRE RISK HAZARD / DELAYED IGNITION

High supply pressure will damage the valve / controls.



Disconnect the appliance main gas valve/control from the supply piping when pressure testing that system at pressures in excess of 1/2 psi (3.5 kPa).

Isolate the appliance with it's shut off valve during any pressure testing of the supply piping at pressures equal to or less than 1/2 psi (3.5 kPa).

table of contents

1.0	general information	5	7.0	electrical information	45
1.1	rates and efficiencies	6	7.1	hard wiring connection	45
1.2	installation checklist	7	7.2	receptacle wiring diagram	45
1.3	installation overview	8	7.3	in the event of a power failure	45
1.4	Dynamic Heat Control™	9	7.4	battery holder/switch installation	46
1.5	rating plate/lighting instruction location	11	7.5	initializing the battery holder/switch for the first time	46
1.6	mobile home installation	12	7.6	wiring diagram	47
1.7	hardware list	12	7.7	eFire controller application	47
1.8	lifting handles installation/removal	12	7.7.1	LVX38-1/ LVX50-1 wiring diagram	48
2.0	dimensions	13	7.7.2	LVX62-1/ LVX74-1 wiring diagram	49
2.1	single-sided	13	7.8	access panel	50
2.2	see-thru	14	8.0	gas installation	51
3.0	minimum venting requirements	15	9.0	operation	52
3.1	typical venting installation	17	9.1	pilot-on-demand	53
3.2	minimum air terminal location clearances	19	10.0	nauling tab installation	54
3.3	horizontal termination	20	11.0	finish framing - after appliance installation	55
3.4	vertical termination	23	11.1	framing with Dynamic Heat Control™	55
3.5	LVX38-1 venting configurations	24	12.0	finishing	60
3.6	LVX50-1 / LVX62-1 venting configurations	25	12.1	fastener placement restriction	60
3.7	LVX74-1 venting configurations	26	12.2	enclosure design	61
4.0	installation planning	27	12.3	finishing with combustibles	62
4.1	installation option 1 - open enclosure (enclosure stops short of the ceiling)	29	12.4	minimum combustible mantel clearances	64
4.2	installation option 2 - front opening	30	12.5	optional trim finishing	65
4.3	installation option 3 - Rear Opening	31	12.6	glass guard installation / removal	66
4.4	installation option 4 - open enclosure with hard combustible valance	32	12.7	firebox glass door installation / removal	75
5.0	rough framing - before appliance installation	33	12.8	media tray removal	76
5.1	minimum framing dimensions	34	12.9	media installation / removal	77
5.1.1	minimum clearance to combustible enclosures	35	13.0	adjustments	78
6.0	venting installation	38	13.1	restricting vertical vents	78
6.1	firestop spacer assembly	38	13.2	venturi adjustment	78
6.2	horizontal installation	40	13.3	pilot burner adjustment	79
6.3	vertical installation	40	13.4	flame characteristics	79
6.4	using flexible vent components	41	14.0	maintenance	80
6.4.1	horizontal air terminal installation	41	14.1	annual maintenance	81
6.5	vertical air terminal installation	42	14.2	control access	81
6.5.1	appliance vent connection	42	14.3	burner removal	82
6.6	restricting vertical vents	43	14.4	valve removal	82
6.6.1	LVX38-1 / LVX50-1	43	14.5	control module removal	83
6.6.2	LVX62-1 / LVX74-1	43	14.6	LED replacement	84
6.7	vent shield installation	44	14.7	glass / door replacement	85
			14.8	care of glass	85
			14.9	care of plated parts	85
			15.0	replacement parts	86
			15.1	overview	87
			15.2	burner components	88
			16.0	troubleshooting	90
			17.0	warranty	93

note:

The information throughout this manual is believed to be correct at the time of printing. Wolf Steel Ltd. reserves the right to change or modify any information within this manual at any time without notice. Changes, other than editorial are denoted by a vertical line in the margin.

Installer: please fill out appliance checklist in the owner's manual.

1.0 general information

When the appliance is installed at elevations above 4,500ft (1372m), and in the absence of specific recommendations from the local authority having jurisdiction, the certified high altitude input rating shall be reduced at the rate of 4% for each additional 1,000ft (305m). Expansion / contraction noises during heating up and cooling down cycles are normal and are to be expected. Change in flame appearance from "HI" to "LO" is more evident in natural gas than in propane.

This appliance is approved for bathroom, bedroom and bed-sitting room installations and is certified for mobile home installation.

This appliance is only for use with the type of gas indicated on the rating plate. This appliance is not convertible for use with other gases, unless a certified kit is used.

There is a switch that controls the function of the appliance. The battery holder/switch must be placed in the middle position. If the switch is not placed in the middle position, the appliance will not work.

note:

A glass guard assembly designed to reduce the risk of burns is provided with the appliance and must be installed. Never operate the appliance without the complete Glass Guard Barrier System installed and closed.

The protective wrap on plated parts is best removed when the assembly is at room temperature but this can be improved if the assembly is warmed, using a hair dryer or similar heat source. The protective wrap must be removed before operating the appliance.

This appliance is a decorative product. It is not a source of heat and not intended to burn solid fuel.

This appliance is equipped with a remote control and a wall switch, which requires batteries to be installed. The remote takes 3 "AAA" batteries and the wall switch takes 4 "AA" batteries.



Batteries must be disposed of according to the local laws and regulations. Some batteries may be recycled, and may be accepted for disposal at your local recycling center. Check with your municipality for recycling instructions.

important:

Some components and/or media are packaged separately and must be installed in accordance with the information in this manual.

general information

1.1 rates and efficiencies

LVX38-1	Single-Sided		See-thru	
	Appliance Type	LVX38N-1	LVX38P-1	LVX38N2-1
Fuel Type	Natural Gas	Propane	Natural Gas	Propane
Altitude (FT)	0-4,500			
Max. Input (BTU/HR)	31,000	26,500	31,000	26,500
Min. Input (BTU/HR)	22,000			

LVX50-1	Single-Sided		See-thru	
	Appliance Type	LVX50N-1	LVX50P-1	LVX50N2-1
Fuel Type	Natural Gas	Propane	Natural Gas	Propane
Altitude (FT)	0-4,500			
Max. Input (BTU/HR)	38,000	31,500	38,000	31,500
Min. Input (BTU/HR)	26,000	25,000	26,000	25,000

LVX62-1	Single-Sided		See-thru	
	Appliance Type	LVX62N-1	LVX62P-1	LVX62N2-1
Fuel Type	Natural Gas	Propane	Natural Gas	Propane
Altitude (FT)	0-4,500			
Max. Input (BTU/HR)	44,000	35,000	44,000	35,000
Min. Input (BTU/HR)	32,000	28,000	32,000	28,000

LVX74-1	Single-Sided		See-thru	
	Appliance Type	LVX74N-1	LVX74P-1	LVX74N2-1
Fuel Type	Natural Gas	Propane	Natural Gas	Propane
Altitude (FT)	0-4,500			
Max. Input (BTU/HR)	50,000	41,500	50,000	41,500
Min. Input (BTU/HR)	35,000	33,000	35,000	33,000

LVX38-1 / LVX50-1 / LVX62-1 / LVX74-1

	Natural Gas		Propane	
	Min. Inlet Gas Supply Pressure	4.5" w.c. (11mb)	11" w.c. (27mb)	4.5" w.c. (11mb)
Max. Inlet Gas Supply Pressure	7"* w.c. (17mb)	13" w.c. (32mb)	13" w.c. (32mb)	13" w.c. (32mb).
Manifold Pressure (Under Flow Conditions)	3.5" w.c. (9mb)	10" w.c. (25mb)	3.5 w.c. (9mb)	10" w.c. (25mb)

*Maximum inlet pressure not to exceed 13" w.c. (32mb).

1.2 installation checklist

GAS FIREPLACE INSTALLATION CHECKLIST

Customer:	_____	Date Installed:	_____
Address:	_____	Installer:	_____
Model:	_____	Dealer:	_____
Serial #:	_____	Dealer Phone #:	_____

This checklist is a reference tool only. It is not intended as a substitute for the installation instructions.

<u>Fireplace Installation</u>	YES	<u>IF NOT, PLEASE EXPLAIN WHY?</u>
Is the fireplace level and secured?	<input type="checkbox"/>	_____
Are the factory supplied non-combustible materials installed?	<input type="checkbox"/>	_____
Is the exterior wall insulated and dry-walled?	<input type="checkbox"/>	_____
Are the clearances to combustibles maintained?	<input type="checkbox"/>	_____
Are the logs/media installed as instructed?	<input type="checkbox"/>	_____
Are the accessories installed as instructed?	<input type="checkbox"/>	_____
Is the glass door properly sealed and unobstructed?	<input type="checkbox"/>	_____
Is the safety barrier installed and secure?	<input type="checkbox"/>	_____
Are all required accessories installed (i.e. door trims)?	<input type="checkbox"/>	_____
<u>Venting Installation</u>		
Is the venting configuration within the parameters?	<input type="checkbox"/>	_____
Has the venting been sealed with the appropriate sealant?	<input type="checkbox"/>	_____
Is the venting supported and secured?	<input type="checkbox"/>	_____
Are all clearances to combustibles maintained?	<input type="checkbox"/>	_____
Are the appropriate firestops and shields properly installed?	<input type="checkbox"/>	_____
Is the terminal, level, secured and sealed?	<input type="checkbox"/>	_____
<u>Gas and Electrical</u>		
Was the fireplace converted to propane?	<input type="checkbox"/>	_____
Was the appropriate supply pressure verified?	<input type="checkbox"/>	_____
Were all gas connections leak tested?	<input type="checkbox"/>	_____
Is the 110 VAC supply connection to the fireplace compliant?	<input type="checkbox"/>	_____
Are all electrical wires protected from damage?	<input type="checkbox"/>	_____
<u>Finishing</u>		
Non-combustible materials used as per instructions?	<input type="checkbox"/>	_____
Enclosure instructions forwarded to builder/finisher?	<input type="checkbox"/>	_____
Minimum enclosure dimensions compliant?	<input type="checkbox"/>	_____
Combustible Mantle Clearances compliant?	<input type="checkbox"/>	_____
<u>Commissioning</u>		
Was the fireplace test fired and all operation verified?	<input type="checkbox"/>	_____
Safety and lighting instructions reviewed with the Customer?	<input type="checkbox"/>	_____
Operating Instruction Manual left with the Customer?	<input type="checkbox"/>	_____

Wolf Steel Ltd. recommends photographs of the various stages of construction be filed along with a copy of this completed form.

1.3 installation overview

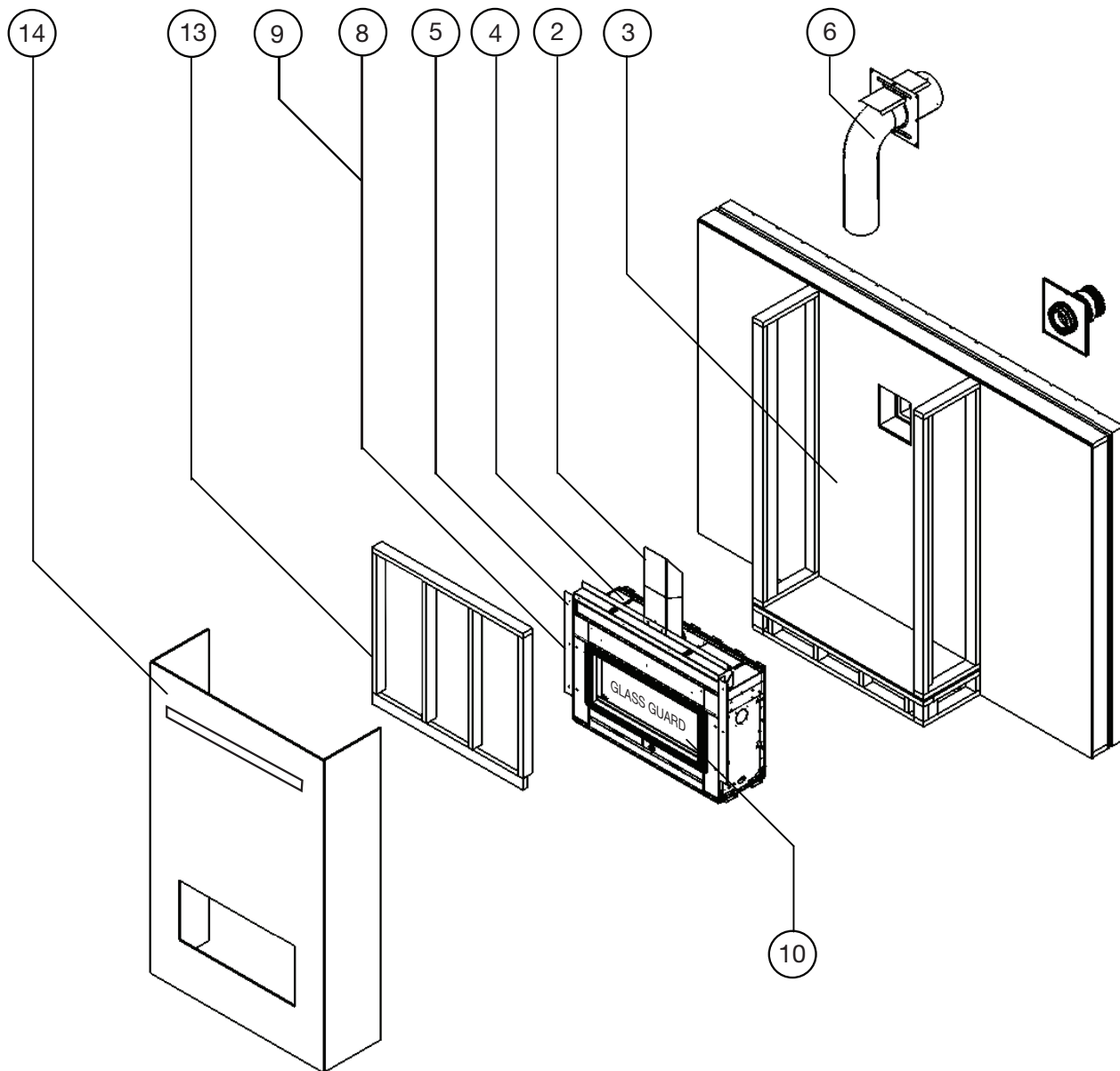
**Recommended installation steps:**

1. Determine venting requirements before deciding the final location of the appliance
2. Plan out appliance enclosure, framing, fronts, accessories, etc.
3. Install rough framing (refer to “rough framing” section)
4. Place the appliance in its final position
5. Install nailing tabs (refer to “nailing tab installation” section)
6. Install appliance venting (refer to “venting installation” section)
7. Install vent shield (refer to “vent shield installation” section)
8. Install all electrical wirings (refer to “electrical information” section)
9. Install gas lines (refer to “gas installation” section)
- 10. Fit glass guard** (refer to “glass guard assembly installation / removal” section)
11. Test appliance (Glass Guard must be installed while testing the appliance)
12. Remove and protect glass guard. Take great care to store using original packaging.
13. Complete framing (refer to “finish framing” section)
14. Finishing (refer to “finishing” section)
15. If necessary, do final adjustments to glass guard.
16. Complete installation checklist in the owner’s manual and apply the serial number to owner’s manual

1.4 Dynamic Heat Control™



Dynamic Heat Control™ is a system for managing the heat produced by the appliance at and around the fireplace. The purpose of the **Dynamic Heat Control™** is to move the heat away from the fireplace to allow it to circulate more effectively within the living space. By installing the **Dynamic Heat Control™** both the installer and the user gain considerable benefits, see the following;

PATENT PENDING

Installer:

- Ability to use combustible framing and finishing right up to the fireplace opening.*
- High temperatures above the front of the fireplace opening are significantly reduced eliminating potential degrading to sensitive finish material (cracks or discoloration).
- No additional electricals, fans, ducts, or manifolds are required which keeps installation straightforward.

User:

- Heat is circulated more consistently throughout the living space increasing comfort in front of the fireplace.
- Increased “real world” efficiency as heat is moved in to the room rather than retained inside an enclosure.
- Complete flexibility in selection of finish materials.
- Ability to place a TV, sound bar or artwork above the fireplace.**

The **Dynamic Heat Control™** system relies on an optimized flow of air both through the appliance and the enclosure. As such the installation of the **Dynamic Heat Control™** system requires certain technical considerations when compared to traditional fireplaces. Specifically, the **Dynamic Heat Control™** requires the **enclosure to be ventilated** and requires the installer to ensure that a minimum opening area is provided to allow heat to escape and circulate at a prescribed minimum height and position. This **must** be carefully adhered to in the planning and the installation to ensure the appliance functions safely and to minimize installation time.

***In most common installation configurations, some specific installations require special provisions. See “framing with Dynamic Heat Control™” section for details. Ensure to strictly adhere to instructions.**

**** Always check the appliance manufacturer’s recommendations to confirm suitability and any special environmental limitations. For valuable or antique items, always refer to expert preservation instructions as some items require specifically controlled temperature and/or humidity**

general information

WARNING

- Always light the pilot whether for the first time or if the gas supply has run out, with the glass door opened or removed.
- Provide adequate clearance for servicing and operating the appliance.
- Provide adequate ventilation.
- Never obstruct the front opening of the appliance.
- Objects placed in front of the appliance must be kept a minimum of 48" (121.9cm) from the front face of the appliance.
- Surfaces around and especially above the appliance can become hot. Avoid contact when appliance is operating.
- Fire risk. Explosion hazard.
- High pressure will damage valve. Disconnect gas supply piping before pressure testing gas line at test pressures above 1/2 PSIG. Close the manual shut-off valve before pressure testing gas line at test pressures equal to or less than 1/2 PSIG (35mb).
- Use only Wolf Steel approved optional accessories and replacement parts with this appliance using non-listed accessories (blowers, doors, louvres, trims, gas components, venting components, etc.) could result in a safety hazard and will void the warranty and certification.
- The appliance must not be operated at temperatures below freezing (32°F / 0°C). Allow the appliance to warm to above freezing prior to operation.
- This appliance has been designed and certified for indoor use only.

THIS GAS APPLIANCE MUST BE INSTALLED AND SERVICED BY A QUALIFIED INSTALLER to conform with local codes. Installation practices vary from region to region and it is important to know the specifics that apply to your area, for example in the state of Massachusetts:

- This product must be installed by a licensed plumber or gas fitter when installed within the commonwealth of Massachusetts.
- The appliance damper must be removed or welded in the open position prior to installation of an appliance insert or gas log.
- The appliance off valve must be a "T" handle gas cock.
- The flexible connector must not be longer than 36 inches (0.9m).
- A carbon monoxide detector is required in all rooms containing gas fired appliances.
- The appliance is not approved for installation in a bedroom or bathroom unless the unit is a direct vent sealed combustion product.

The installation must conform with local codes or, in absence of local codes, the National Gas and Propane Installation Code CSA B149.1 in Canada, or the National Fuel Gas Code, ANSI Z223.1 / NFPA 54 in the United States. Suitable for mobile home installation if installed in accordance with the current standard CAN/CSA Z240MH Series, for gas equipped mobile homes, in Canada or ANSI Z223.1 and NFPA 54 in the United States.

The appliance and its individual shutoff valve must be disconnected from the gas supply piping system during any pressure testing of that system at test pressures in excess of 1/2 psig (35 mb).

The appliance must be isolated from the gas supply piping system by closing its individual manual shutoff valve during any pressure testing of the gas supply piping system at test pressures equal to or less than 1/2 psig (35 mb). When installed with a blower or fan, the junction box must be electrically connected and grounded in accordance with local codes. In the absence of local codes, use the current CSA C22.1 Canadian Electrical Code in Canada or the ANSI / NFPA 70 National Electric Code in the United States. In the case where the blower is equipped with a power cord, it must be connected into a properly grounded receptacle. The grounding prong must not be removed from the cord plug.

The following does not apply to inserts; as long as the required clearance to combustibles is maintained, the most desirable and beneficial location for an appliance is in the center of a building, thereby allowing the most efficient use of the heat created. The location of windows, doors and, the traffic flow in the room where the appliance is to be located should be considered. If possible, you should choose a location where the vent will pass through the house without cutting a floor or roof joist. If the appliance is installed directly on carpeting, vinyl tile or other combustible material other than wood flooring, the appliance shall be installed on a metal or wood panel extending the full width and depth, unless otherwise tested.



We suggest that our gas hearth products be installed and serviced by professionals who are certified in the U.S. by the National Fireplace Institute® (NFI) as NFI Gas Specialists

1.5 rating plate/lighting instruction location

Both the rating plate and lighting instructions are attached to a chain located on the left side of the control area near the valve (access side). Remove the glass guard and the control cover to gain access to the control area.

To replace, slide the instructions back into the control area and slide the glass front into its locked position.

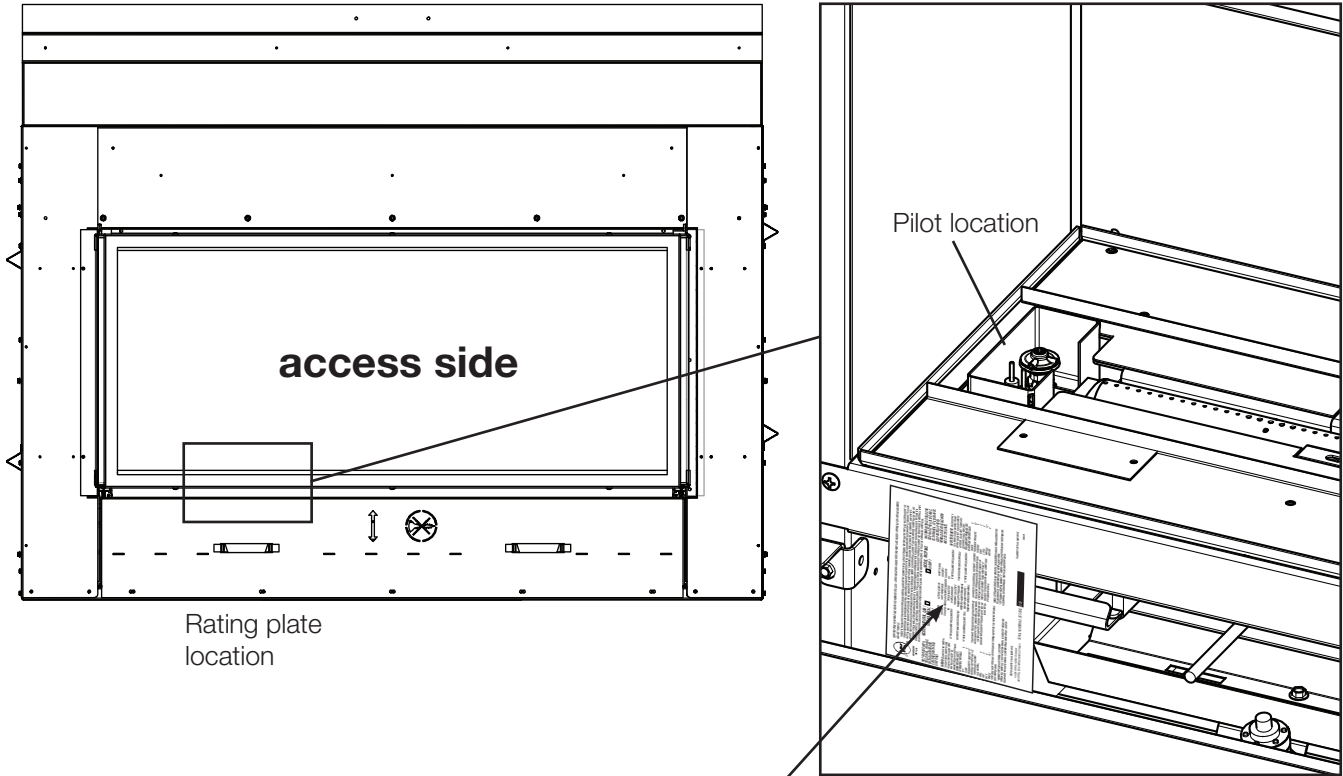

Certified to Canadian and American National Standards: **CSA 2.22-XXXX / ANSI Z21.50-XXXX for Vented Decorative Gas Appliances**
 Certifié selon les normes Nationales Canadiennes et Américaines: **CSA 2.22-XXXX / ANSI Z21.50-XXXX pour les Appareils à gaz décoratif à évacuation**

Direct vent, vented gas fireplaces. Approved for bedroom, bathroom and bed-sitting room installation. Suitable for mobile home installation, if installed in accordance with the current standard CAN / CSA Z240MH Series gas equipped mobile homes in Canada, or, in the United States, the *Manufactured Home Construction and Safety Standard, Title 24 CFR, Part 3280*. When this US Standard is not applicable, use the *Standard for Fire Safety Criteria for Manufactured Home Installations, Sites and Communities, ANSI / NFPA 501A*. This appliance must be installed in accordance with local codes, if any; if none, follow the current ANSI Z223.1 or CSA B149. **For use with barrier WXXX-XXXX. Follow installation instructions.**
 Foyer à gaz ventilé. Homologué pour installation dans une chambre à coucher, une salle de bain et un studio. Approuvé pour installation dans une maison mobile si son installation conforme aux exigences de la norme CAN / CSA Z240MH Série de maisons mobile équipées au gaz en vigueur au Canada, ou, aux États-Unis selon la norme 24 CFR, Part 3280, *Manufactured Home Construction and Safety Standard*. Dans le cas où cette norme d'États-Unis n'est pas pertinente, utiliser la norme NFPA 501A, *Fire Safety Criteria for Manufactured Home Installations, Sites and Communities*. Installer l'appareil selon les codes ou règlements locaux ou, en l'absence de tels règlements, selon les codes d'installation ANSI Z223.1 ou CSA B149 en vigueur. **Utiliser uniquement avec l'écran WXXX-XXXX. Suivre les instructions d'installation.**

CSA 149 en vigueur. Utiliser uniquement avec l'écran WXXX-XXXX. Suivre les instructions d'installation.

9700539 (WSL) 4001658 (NAC) 4001657 (NGZ) 4001659 (WUSA)

MODEL / MODÈLE

<input type="checkbox"/> XXXX	<input type="checkbox"/> XXXX	<input type="checkbox"/> XXXX	<input type="checkbox"/> XXXX
<input type="checkbox"/> XXXX	<input type="checkbox"/> XXXX	<input type="checkbox"/> XXXX	<input type="checkbox"/> XXXX

Altitude Input Reduced Input P4
 Manifold Pressure: 3.5" w.c. (NG)
 Minimum Supply Pressure: 4.5" w.c. (NG)
 Maximum Supply Pressure: 7" w.c. (NG)
 Pression au Collecteur: 3.5" d'une colonne d'eau (GN)
 Pression d'Alimentation Min.: 4.5" d'une colonne d'eau (GN)
 Pression d'Alimentation Max.: 7" d'une colonne d'eau (GN)
 Minimum inlet pressure not to exceed 13".

0-XXXXR (0-XXXXm)
 XX,XXX
 XX,XXX
 XX,XXX

Elevation Alimentation Réduite P4
 Manifold Pressure: 10" w.c. (P)
 Minimum Supply Pressure: 11" w.c. (P)
 Maximum Supply Pressure: 13" w.c. (P)
 Pression au Collecteur: 10" d'une colonne d'eau (P)
 Pression d'Alimentation Min.: 11" d'une colonne d'eau (P)
 Pression d'Alimentation Max.: 13" d'une colonne d'eau (P)
 ** Pression d'alimentation maximale ne doit pas dépasser 13".

VENTED DECORATIVE GAS APPLIANCE: NOT A SOURCE OF HEAT, NOT INTENDED FOR USE AS A HEATING APPLIANCE, NOT FOR USE WITH SOLID FUEL.
APPAREIL À GAZ DÉCORATIF À ÉVACUATION: N'EST PAS UNE SOURCE DE CHALEUR; N'EST PAS DESTINÉ À ÊTRE UTILISÉ COMME UN APPAREIL DE CHAUFFAGE; NE CONVIENT PAS AUX COMBUSTIBLES SOLIDES.

FOR USE WITH GLASS DOORS CERTIFIED WITH THIS APPLIANCE ONLY.
POUR UTILISATION UNIQUEMENT AVEC LES PORTES EN VERRE CERTIFIÉES AVEC L'APPAREIL.

For natural gas when equipped with No. XX drill size orifice.
 For propane when equipped with No. XX drill size orifice.
 Convient au gaz naturel quand l'appareil est muni d'un injecteur de diamètre no. XX.
 Convient au propane quand l'appareil est muni d'un injecteur de diamètre no. XX.

WARNING: Do not add any material to the appliance which will come in contact with the flames, other than that supplied by the manufacturer with the appliance.
AVERTISSEMENT: N'ajoutez pas à cet appareil aucun matériau devant entrer en contact avec les flammes autre que celui qui est fourni avec cet appareil par le fabricant.

The appliance must be vented using the appropriate Napoleon vent kits. See installation manual for venting specifications. Proper reinstallation and resealing is necessary after servicing the vent-air intake system.
 L'appareil doit être ventilé à l'aide de l'ensemble d'évacuation propre à Napoleon. Référez au manuel d'installation pour les spécifications d'évacuation. Il est nécessaire de bien réinstaller et resceller l'évacuation après avoir exécuté l'entretien du système de prise d'air.

Top, sides & back: per standoff spacers for framing and finishing materials. For non-combustible framing and finishing materials, see installation manual.
 Dessus, côtés et arrière: selon les espaces de dégagements pour les matériaux d'ossature selon le manuel du propriétaire pour les matériaux de finition.

Top "X"
 Floor "X"
 Sides "X"
 Back "X"
 Vent top "X"
 Vent sides & bottom "X"
 Recessed depth "X"
 *** "Marital "X" from appliance opening
 *** Maximum horizontal extension:
 "X". See installation manual for greater extensions, minimum vent lengths and maximum vent lengths.
 Electrical rating: 115V, 60Hz. Less than 12 amperes.
 Spécifications électriques: 115V, 60Hz. Moins de 12 ampères.

Serial Number / N° de Série: XXXX

WOLF STEEL LTD. 24 Napoleon Road, Barrie, ON, L4M 0G9 Canada **W385-XXXX**

This illustration is for reference only. Refer to the rating plate on the appliance for accurate information.

note:
 The rating plate must remain with the appliance at all times. It must not be removed.

general information

1.6 mobile home installation

This appliance must be installed in accordance with the manufacturer's instructions and the Manufactured Home Construction and Safety Standard, Title 24 CFR, Part 3280, in the United States or the Mobile Home Standard, CAN/CSA Z240 MH Series, in Canada. This appliance is only for use with the type(s) of gas indicated on the rating plate.

This mobile/manufactured home listed appliance comes factory equipped with a means to secure the appliance. The shipping brackets that secure the appliance to the pallet can be used to secure the appliance to the floor for mobile home installation. For mobile home installations, the appliance must be fastened in place.

This appliance is certified to be installed in an aftermarket permanently located, manufactured (mobile) home, where not prohibited by local codes.

This appliance is only for use with the type of gas indicated on the rating plate. This appliance is not convertible for use with other gases, unless a certified kit is used.

Conversion Kits

This appliance is field convertible between Natural Gas (NG) and Propane (P). To convert from one gas to another, consult your Authorized dealer/distributor.

1.7 hardware list

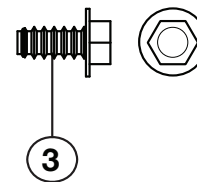
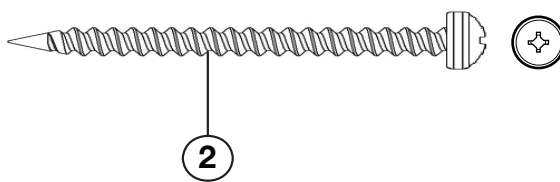
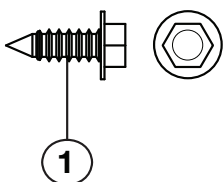

	Description	Quantity
1	Hex Head Sheet Metal Screw	22
2	Pan Head Sheet Metal Screw	4
3	Hex Head Sheet Metal Bolt	18

note:

Only fasteners supplied with the appliance are illustrated.

1.8 lifting handles installation/removal

Remove 4 screws each side (8 total) then install the lifting handles to the side of the appliance and secure using 4 screws each side (8 total). Once the appliance is in place remove the four screws from each handle to the appliance. Discard the lifting handles.

note:

The lifting handles **MUST** be removed prior to rough framing the appliance.

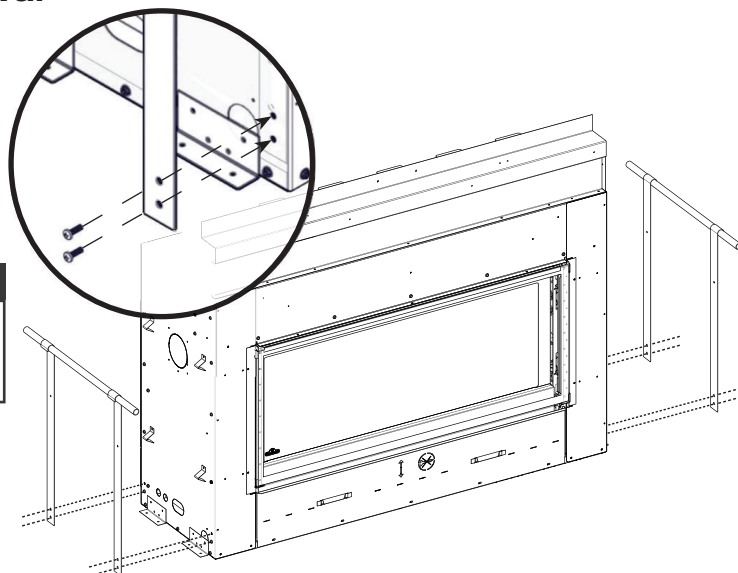

2.1 single-sided

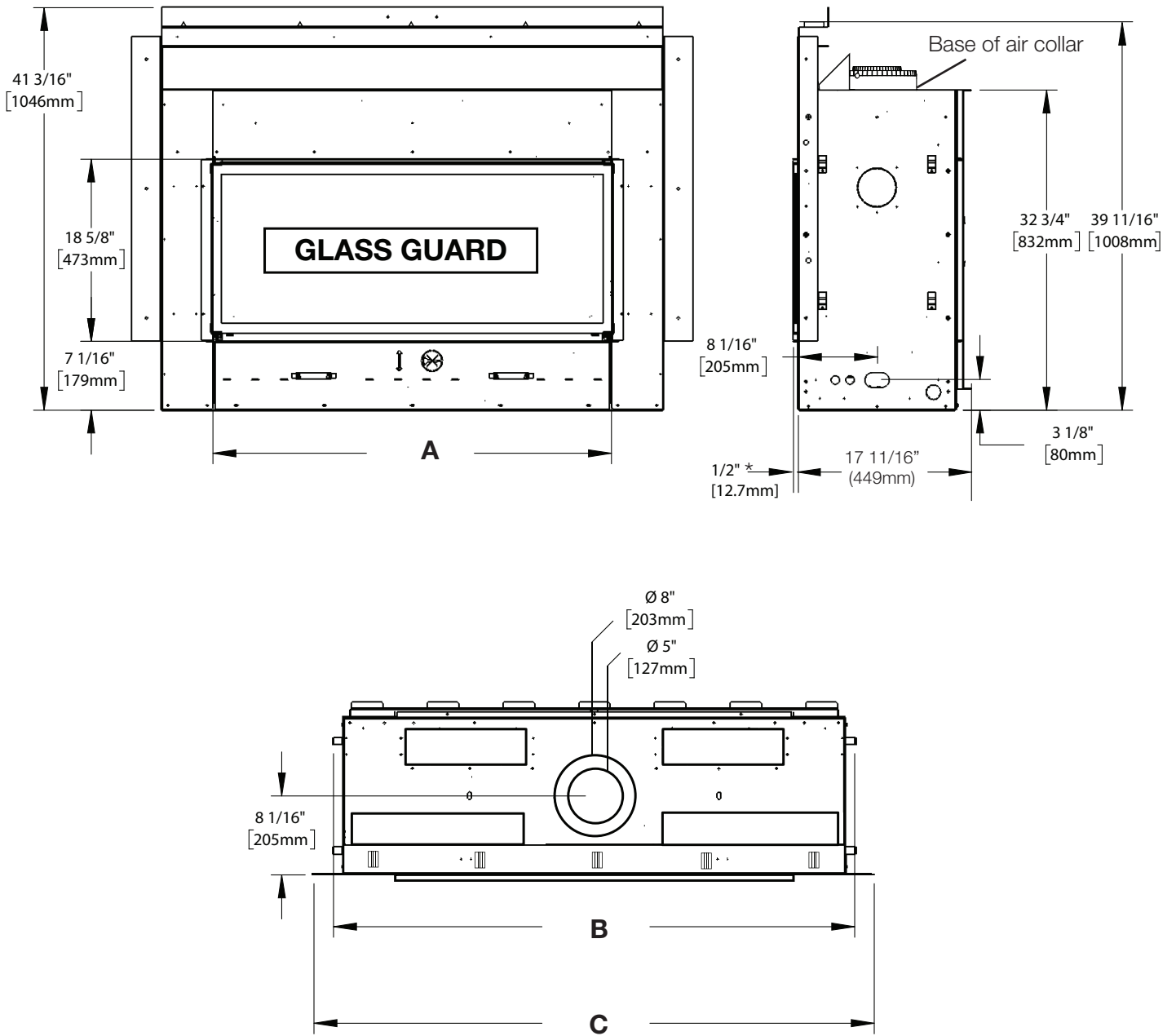

	LVX38-1	LVX50-1	LVX62-1	LVX74-1
A (Finishing Flange)	42 1/8" (1070mm)	54 1/8" (1375mm)	66 1/8" (1680mm)	78 1/8" (1984mm)
B	53 5/16" (1354mm)	65 5/16" (1659mm)	77 5/16" (1964mm)	89 5/16" (2269mm)
C	57 5/16" (1456mm)	69 5/16" (1761mm)	81 5/16" (2065mm)	93 5/16" (2370mm)

*Finishing flange depth (the finishing flange defines the perimeter of the fireplace opening. Framing or finishing materials must NEVER encroach inside the finishing flange).

BN dimensions
2.2 see-thru

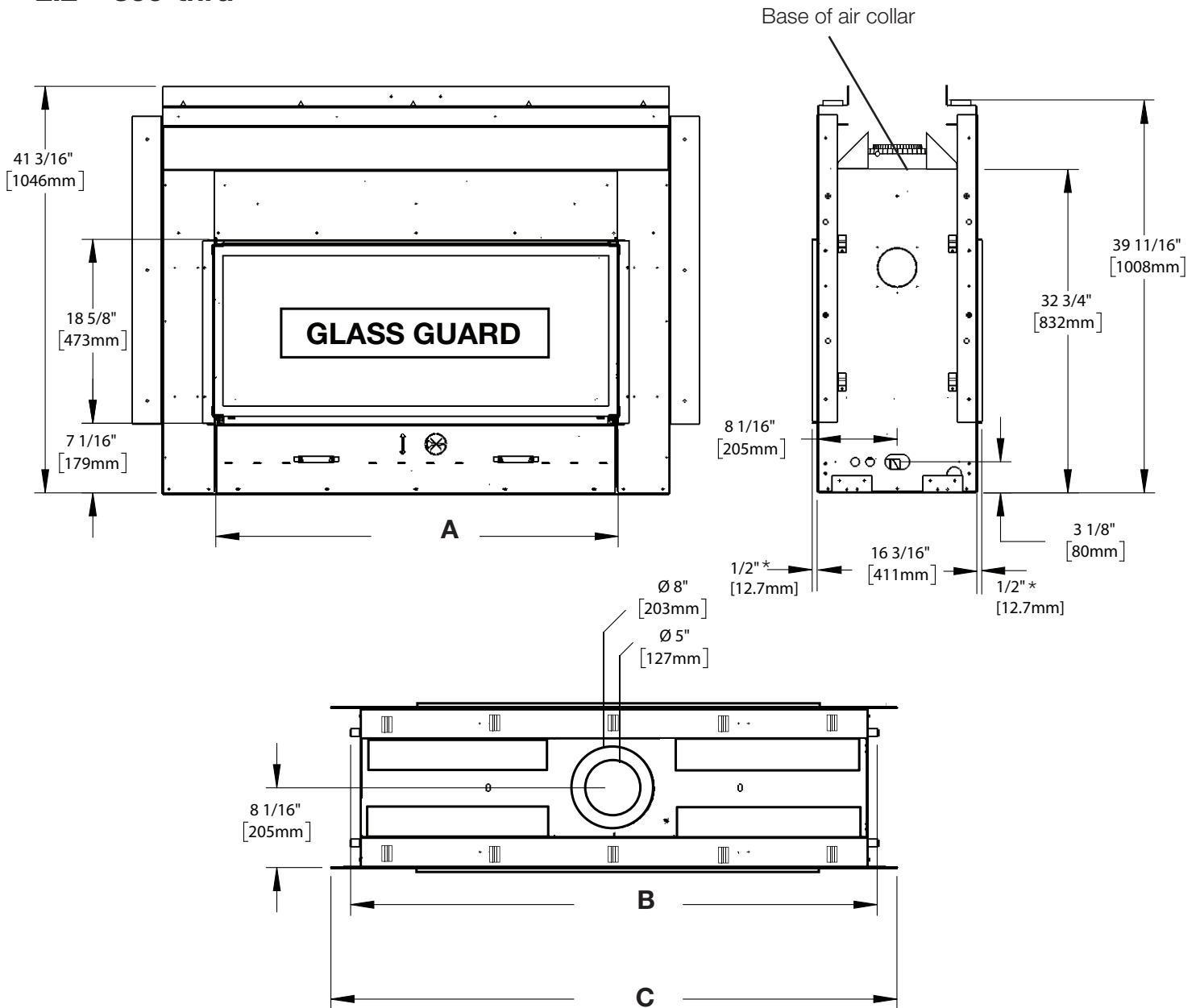

	LVX38-1	LVX50-1	LVX62-1	LVX74-1
A (Finishing Flange)	42 1/8" (1070mm)	54 1/8" (1375mm)	66 1/8" (1680mm)	78 1/8" (1984mm)
B	53 5/16" (1354mm)	65 5/16" (1659mm)	77 5/16" (1964mm)	89 5/16" (2269mm)
C	57 5/16" (1456mm)	69 5/16" (1761mm)	81 5/16" (2065mm)	93 5/16" (2370mm)

*Finishing flange depth (the finishing flange defines the perimeter of the fireplace opening. Framing or finishing materials must NEVER encroach inside the finishing flange).

WARNING

- Risk of fire. Maintain specified air space clearances to vent pipe and appliance.
- The vent system must be supported every 3’(0.9m) for both vertical and horizontal runs. Use support ring assembly W010-0067 or equivalent non-combustible strapping to maintain the minimum clearance to combustibles for both vertical and horizontal runs. Spacers are attached to the inner pipe at predetermined intervals to maintain an even air gap to the outer pipe. This gap is required for safe operation. A spacer is required at the start, middle, and end of each elbow to ensure this gap is maintained. These spaces must not be removed.

This appliance uses a 5” (127mm) exhaust / 8” (203.2mm) air intake vent pipe system. Refer to the section applicable to your installation.

For safe and proper operation of the appliance follow the venting instructions exactly. Deviation from the minimum vertical vent length can create difficulty in burner start-up and/or carboning. Under extreme vent configurations, allow several minutes (5-15) for the flame to stabilize after ignition. Although not a requirement, it is recommended for vent lengths that pass through unheated spaces (attics, garages, crawl spaces) be insulated with the insulation wrapped in a protective sleeve to minimize condensation. Provide a means for visually checking the vent connection to the appliance after the appliance is installed. Use a firestop, vent pipe shield or attic insulation shield when penetrating interior walls, floor or ceiling.

The vent terminal may be painted with a high temperature paint to match exterior colours. Use an outdoor paint suitable for 400°F (200°C). Application and performance of paint is the consumer’s responsibility. Spot testing is recommended.

note:

If for any reason the vent air intake system is disassembled; reinstall per the instructions provided for the initial installation.

This appliance must be installed with a continuous connection of exhaust and air intake vent pipes. Utilizing alternate constructions, such as a chimney as part of the vent system, is not permitted.

Use only Wolf Steel, Metal-Fab, BDM, Simpson Dura-Vent, or Selkirk Direct Temp venting components. Minimum and maximum vent lengths, for both horizontal and vertical installations, clearances from vent pipes to combustibles and air terminal locations as set out in this manual apply to all vent systems and must be adhered to. For Metal-Fab, BDM, Simpson Dura-Vent, or Selkirk Direct Temp, follow the installation procedure provided with the venting components or on the website for your venting supplier.

A starter adaptor must be used with the following vent systems and may be purchased through Wolf Steel or from the corresponding supplier listed below:

Venting System	Manufacturer	Starter Adapter Part Number	Supplier	Website
SureSeal	Metal-Fab	5DNA	Wolf Steel	www.mtlfab.com
Direct Vent Pro	Simpson DuraVent	W175-0170	Wolf Steel	www.duravent.com
Pro-Form	BDM	N/A	BDM	www.dalsinmfg.com
Direct Temp	Selkirk	5DT-AAN	Selkirk	www.selkirkcorp.com
Ventis	Olympia Chimney and Venting	VDV-NA05-58F	Olympia Chimney and Venting	www.olympiachimney.com

Connections made by means of an adaptor at the appliance, as well as the connection at the vent terminal must be sealed. RTV sealant may be used on both the inner exhaust and outer intake vent pipe joints of all other approved vent systems, except for the exhaust vent pipe connection to the appliance flue collar which must be sealed using the black high temperature sealant Mill Pac.

For all vent systems is strongly recommend for all installations but required when power venting the appliance, that the outer air intake joints are sealed using either high temperature silicone (RTV) or a suitable aluminum tape that covers each joint in the vent system entirely around its circumference. This will ensure the best performance in every application and avoids performance or condensation concerns that may occur in “tightly” constructed homes, particularly those in cold climates.

When using Wolf Steel venting components, use only approved Wolf Steel rigid / flexible components with the following termination kits: wall terminal kit **GD422R-2** or **ST58U-1**, or 1/12 to 7/12 pitch roof terminal kit **GD410**, 8/12 to 12/12 roof terminal kit **GD411**, flat roof terminal kit **GD412** or periscope kit **GD401** (for wall penetration below grade). With flexible venting, in conjunction with the various terminations, use either the 5 foot (1.5m) vent kit **GD420** or the 10 foot (3.1m) vent kit **GD430**.

minimum venting requirements

For optimum flame appearance and appliance performance, keep the vent length and number of elbows to a minimum.

The air terminal must remain unobstructed at all times. Examine the air terminal at least once a year to verify that it is unobstructed and undamaged.

Rigid and flexible venting systems must not be combined. Different venting manufacturer components must not be combined.

These vent kits allow for either horizontal or vertical venting of the appliance. The maximum allowable horizontal run is 20 feet (6.1m). The maximum allowable vertical vent length is 40 feet (12.2m). The maximum number of vent connections is two horizontally or three vertically (excluding the appliance and the air terminal connections) when using flexible venting.

Horizontal runs may have a 0" (0mm) rise per foot/meter however for optimum performance it is recommended that all horizontal runs have a minimum 1/4" (21mm) rise per foot/meter using flexible venting. For safe and proper operation of the appliance, follow the venting instructions exactly.

A terminal shall not terminate directly above a sidewalk or paved driveway which is located between two single family dwellings and serves both dwellings. Local codes or regulations may require different clearances.

Do not allow the inside liner to bunch up on horizontal or vertical runs and elbows. Keep it pulled tight. A 1/4" (31.8mm) air gap all around between the inner liner and outer liner is required for safe operation.

3.1 typical venting installation

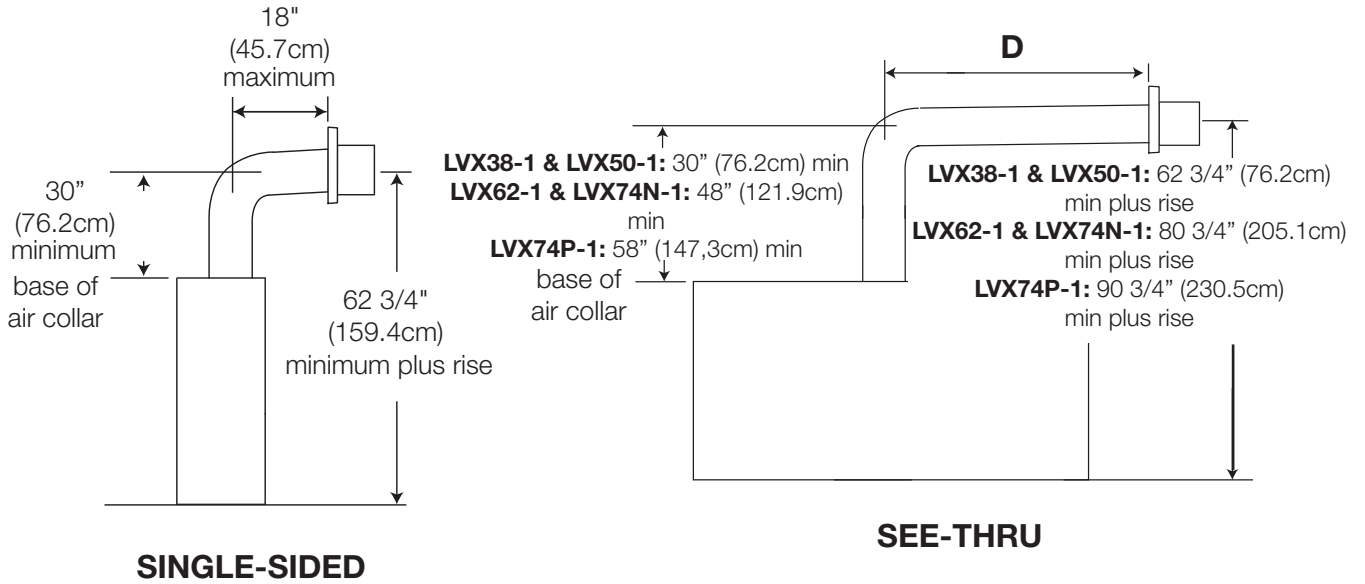

	LVX38-1	LVX50-1	LVX62-1	LVX74-1
D	40" (101.6cm)	46 1/2" (118.1cm)	52 1/2" (133.4cm)	58 1/2" (148.6cm)

special vent installation (periscope termination)

Use the periscope kit to locate the air termination above grade. The periscope must be installed so that when final grading is completed, the bottom air slot is located a minimum 12" (30.5cm) above grade. The maximum allowable vent length is 10' (3m).

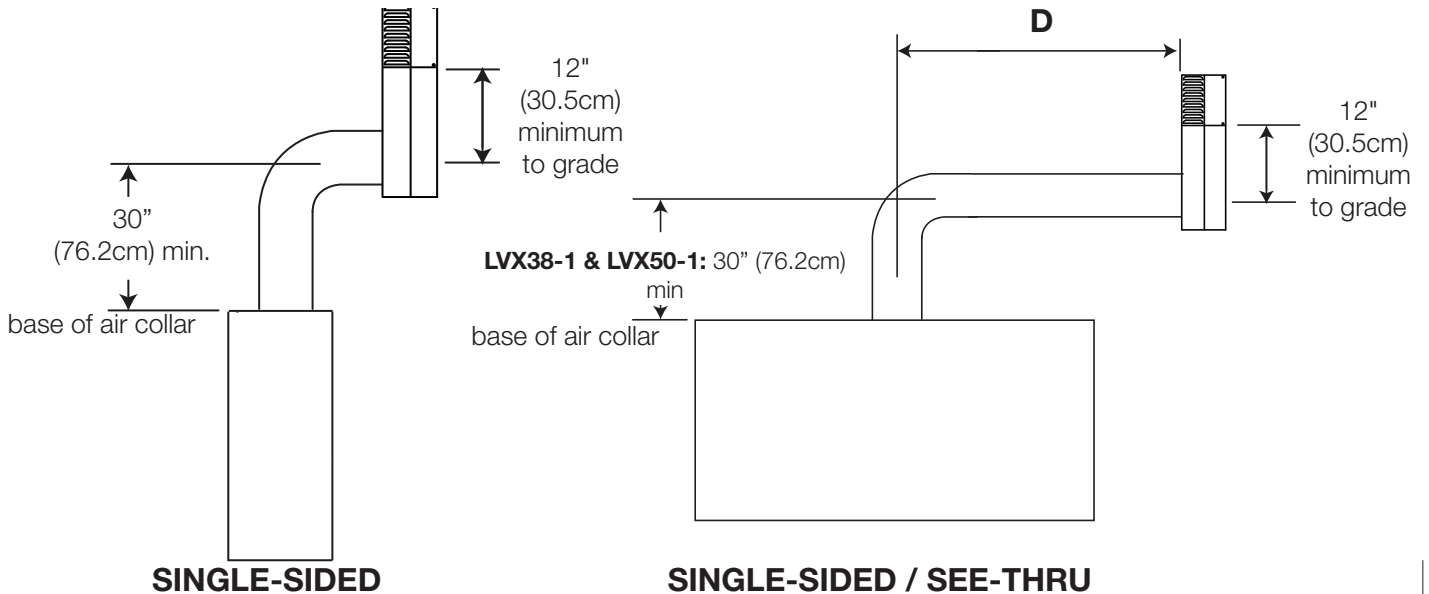

	LVX38-1	LVX50-1	LVX62-1	LVX74-1
D	40" (101.6cm)	46 1/2" (118.1cm)	N/A	N/A

minimum venting requirements

SINGLE-SIDED OR SEE-THRU

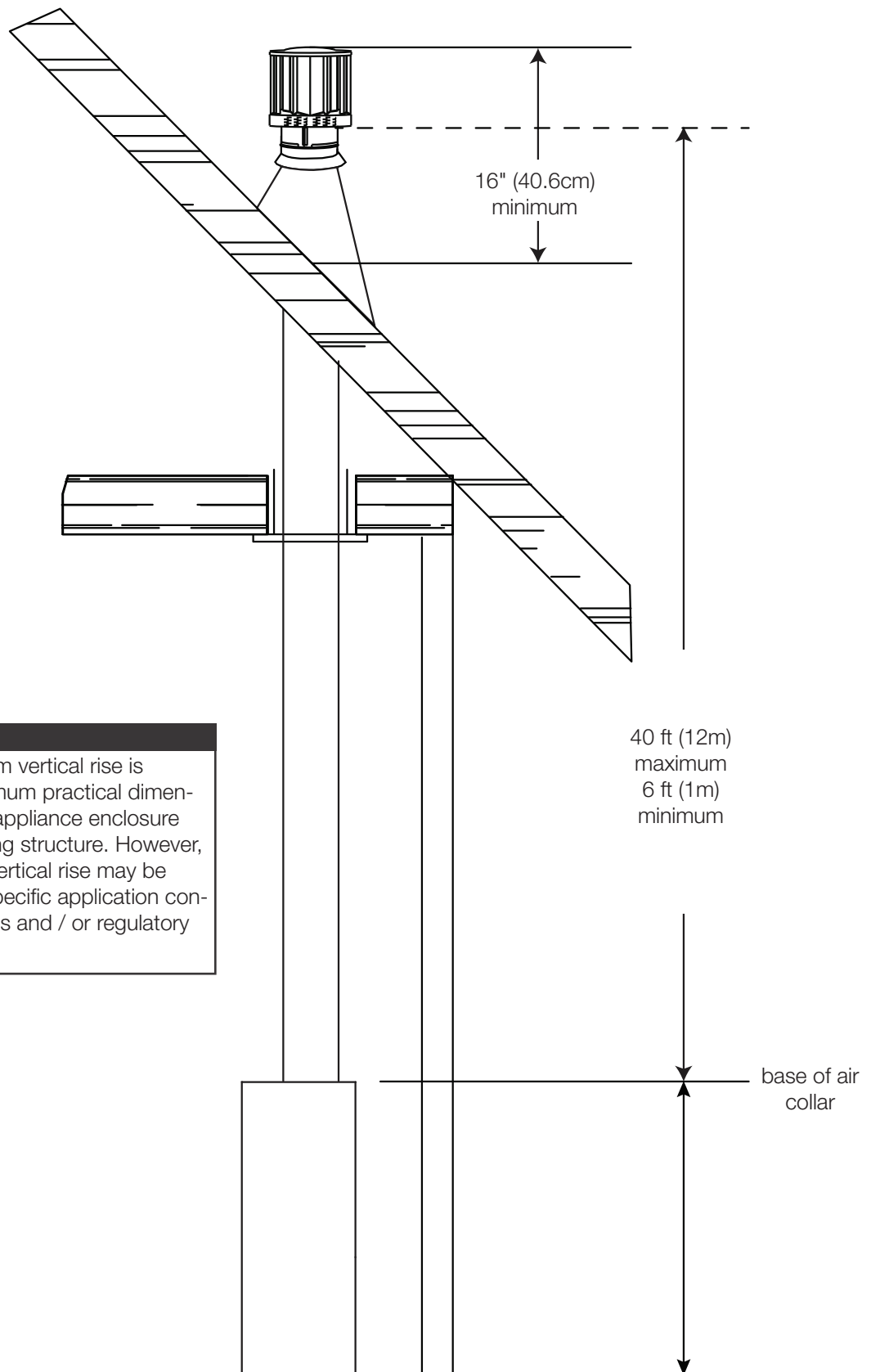

note:

A 6' (1.83m) minimum vertical rise is considered the minimum practical dimension for the specific appliance enclosure and a minimal building structure. However, a greater minimum vertical rise may be needed to suit the specific application constraints or local codes and / or regulatory requirements.

3.2 minimum air terminal location clearances

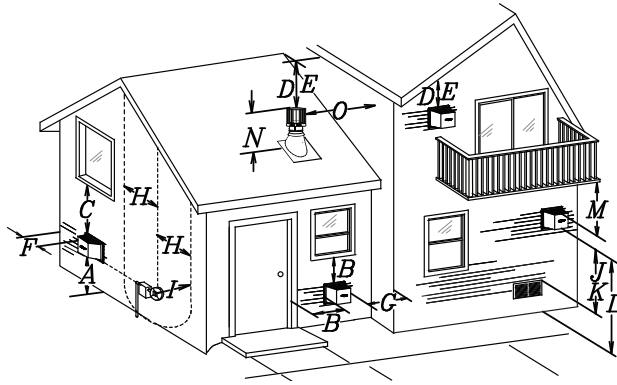

Covered balcony applications ††*

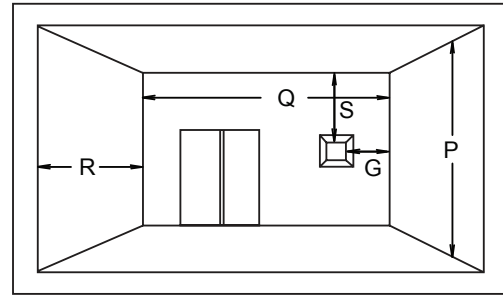

$Q_{\text{MIN}} = 3 \text{ feet}$ (0.9m)	$R_{\text{MAX}} = 2 \times Q_{\text{ACTUAL}}$	$R_{\text{MAX}} \leq 15 \text{ feet}$ (4.6m)
---	---	---

	INSTALLATIONS		note:
	CANADA	U.S.A.	
A	12" (30.5cm)	12" (30.5cm)	Clearance above grade, veranda porch, deck or balcony.
B	12" (30.5cm) ^Δ	9" (229mm) ^Δ	Clearance to windows or doors that open.
C	12" (30.5cm)*	12" (30.5cm)*	Clearance to permanently closed windows.
D	18" (45.7cm)**	18" (45.7cm)**	Vertical clearance to ventilated soffits located above the terminal within a horizontal distance of 2' (0.6m) from the center line of the terminal.
E	12" (30.5cm)**	12" (30.5cm)**	Clearance to unventilated soffit.
F	0" (0mm)	0" (0mm)	Clearance to an outside corner wall.
G	0" (0mm)***	0" (0mm)***	Clearance to an inside non -combustible corner wall or protruding non -combustible obstructions (chimney, etc.).
	2" (51mm)***	2" (51mm)***	Clearance to an inside combustible corner wall or protruding combustible obstructions (vent chase, etc.).
H	3'(0.9m)	3'(0.9m)****	Clearance to each side of the center line extended above the meter / regulator assembly to a maximum vertical distance of 15' (4.6m).
I	3' (0.9m)	3' (0.9m)****	Clearance to a service regulator vent outlet.
J	12" (30.5cm)	9" (229mm)	Clearance to a non-mechanical air supply inlet to the building or a combustion air inlet to any other appliance.
K	6' (1.8m)	3' (0.9m) †	Clearance to a mechanical air supply inlet.
L	7' (2.1m) ‡	7' (2.1m) ****	Clearance above a paved sidewalk or paved driveway located on public property.
M	12" (30.5cm)††	12" (30.5cm)****	Clearance under a veranda, porch, deck or overhang.
N	16" (40.6cm)	16" (40.6cm)	Clearance above the roof.
O	2' (0.6m)†*	2' (0.6m) †*	Clearance from an adjacent wall including neighbouring buildings.
P	8' (2.4m)	8' (2.4m)	Roof must be non -combustible without openings.
Q	3' (0.9m)	3' (0.9m)	See chart for wider wall dimensions.
R	6' (1.8m)	6' (1.8m)	See chart for deeper wall dimensions. The terminal shall not be installed on any wall that has an opening between the terminal and the open side of the structure.
S	12" (30.5cm)	12" (30.5cm)	Clearance under a covered balcony

Δ The terminal shall not be located less than 6 feet under a window that opens on a horizontal plane in a structure with three walls and a roof.

* Recommended to prevent condensation on windows and thermal breakage

** It is recommended to use a heat shield and to maximize the distance to vinyl clad soffits.

*** The periscope requires a minimum 18 inches clearance from an inside corner.

**** This is a recommended distance. For additional requirements, check local codes.

† 3 feet above if within 10 feet horizontally.

‡ A vent shall not terminate where it may cause hazardous frost or ice accumulations on adjacent property surfaces.

†† Permitted only if the veranda, porch, or deck is fully open on a minimum of two sides beneath the floor.

†* Recommended to prevent recirculation of exhaust products. For additional requirements, check local codes.

††* Permitted only if the balcony is fully open on a minimum of one side.

note:

Clearances are to be in accordance with local installation codes and the requirements of the gas supplier. In their absence, clearances are to be as listed above and are based on national codes.

minimum venting requirements - natural gas

3.3 horizontal termination

L VX38-1 / L VX50-1 / L VX62-1 / L VX74-1 SINGLE-SIDED & L VX38-1 / L VX50-1 SEE-THRU (NATURAL GAS ONLY)

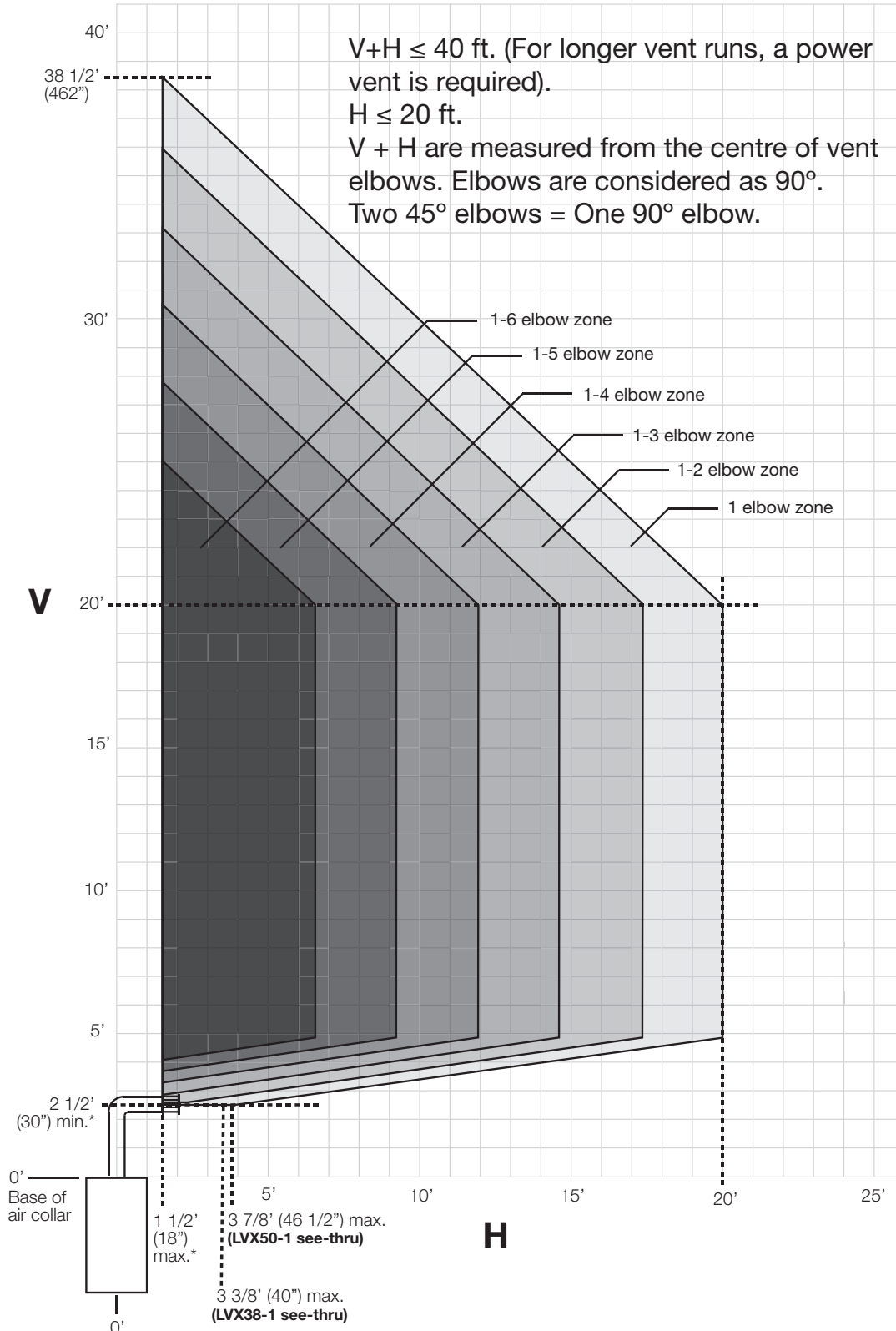

LVX62-1/ LVX74-1 SEE-THRU (NATURAL GAS ONLY)

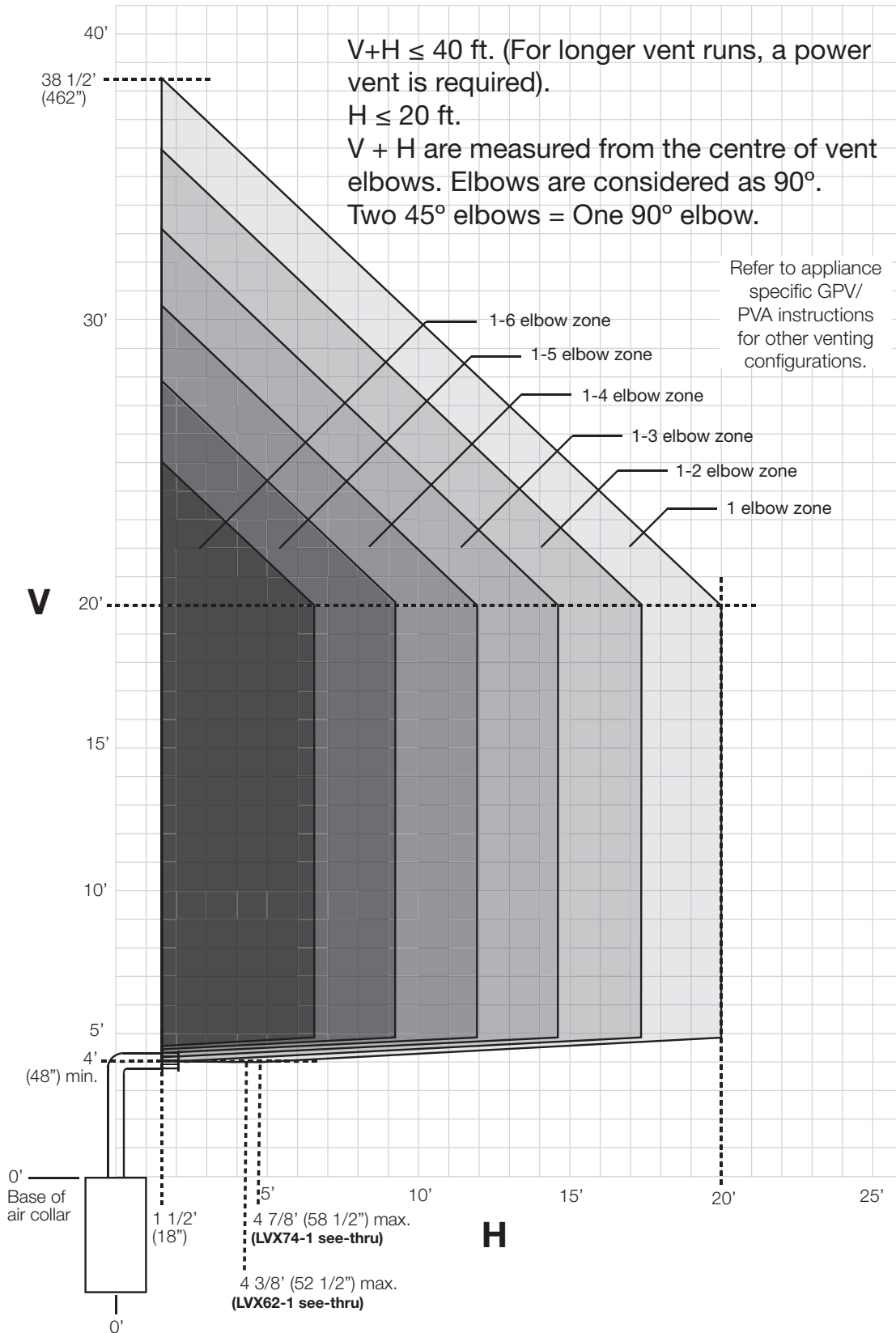

(NATURAL GAS ONLY)

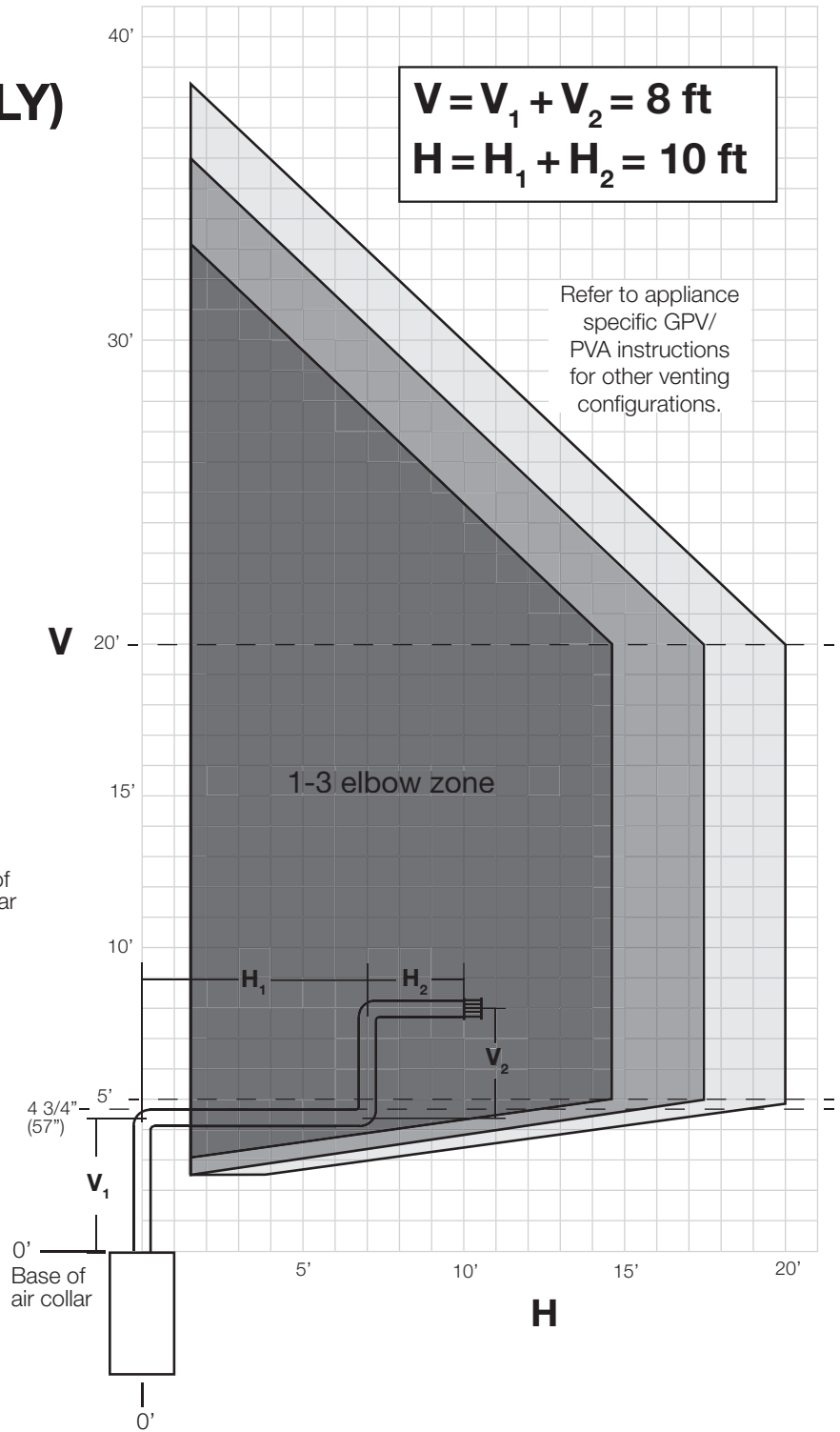
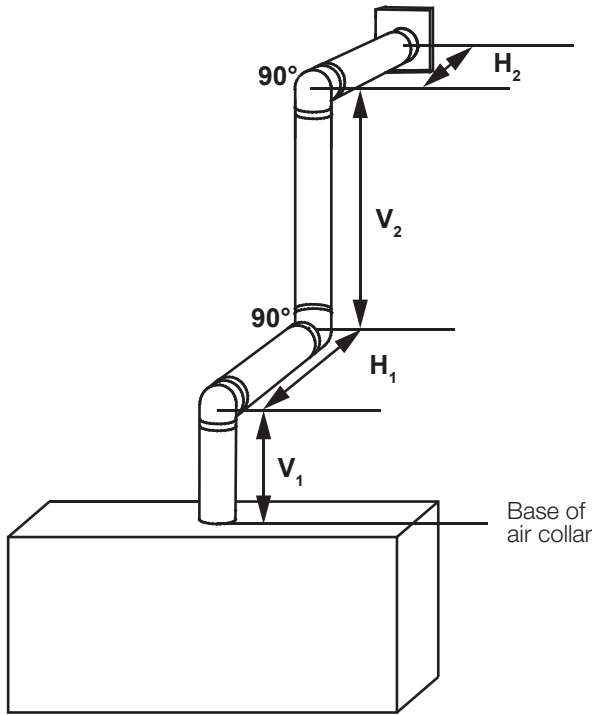

V and H are measured from the center of the vent elbows

This example represents a vent that has a maximum of three 90° elbows, a combined horizontal vent length (H) of 10 feet and a combined vertical vent length (V) of 8 feet.

Since the vent is located in the dark shaded area, it is within the acceptable vent configuration

3.4 vertical termination

**ALL APPLIANCES
(NATURAL GAS ONLY)**

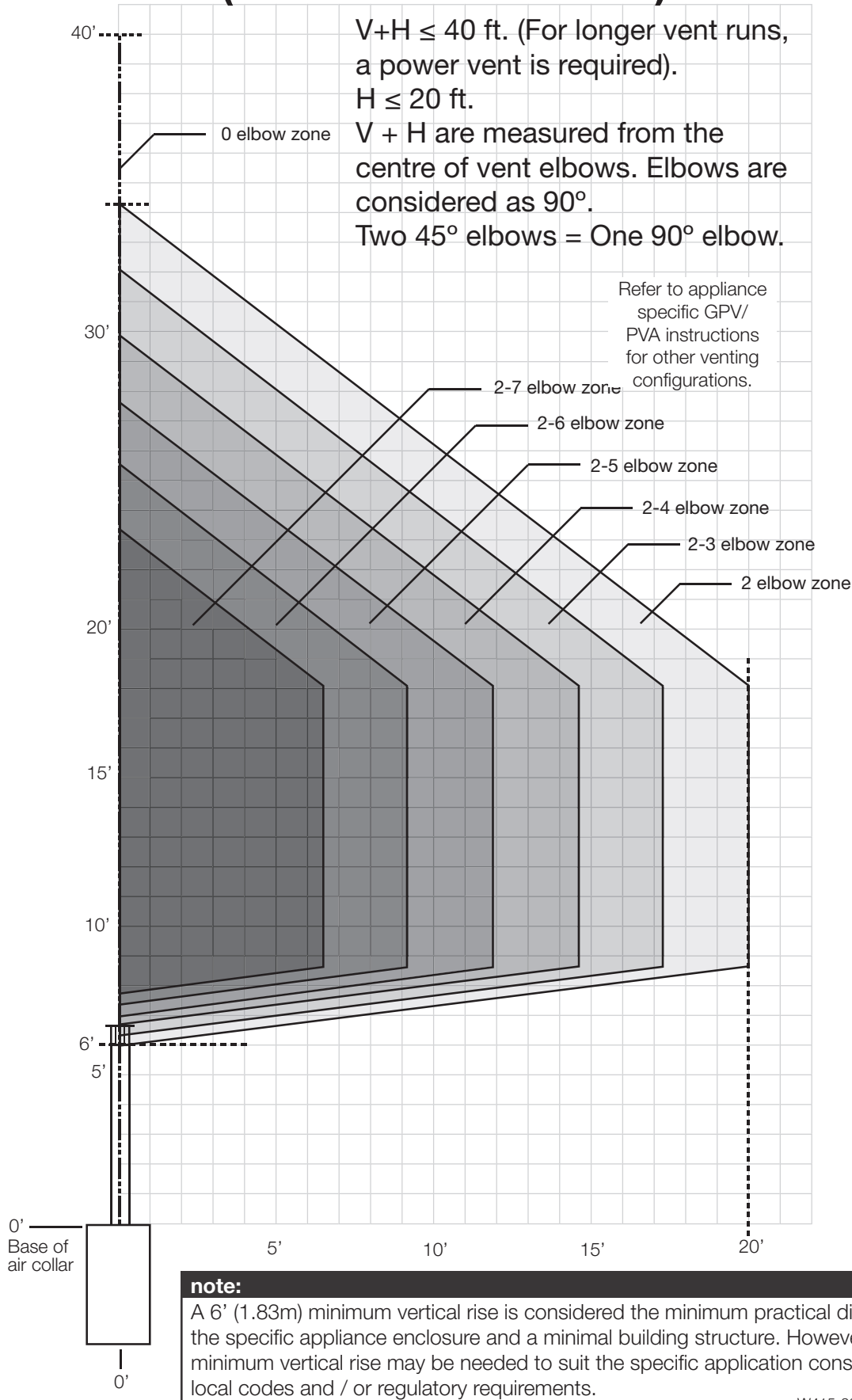

BN minimum venting requirements - propane

3.5 LVX38-1 venting configurations

(PROPANE ONLY)

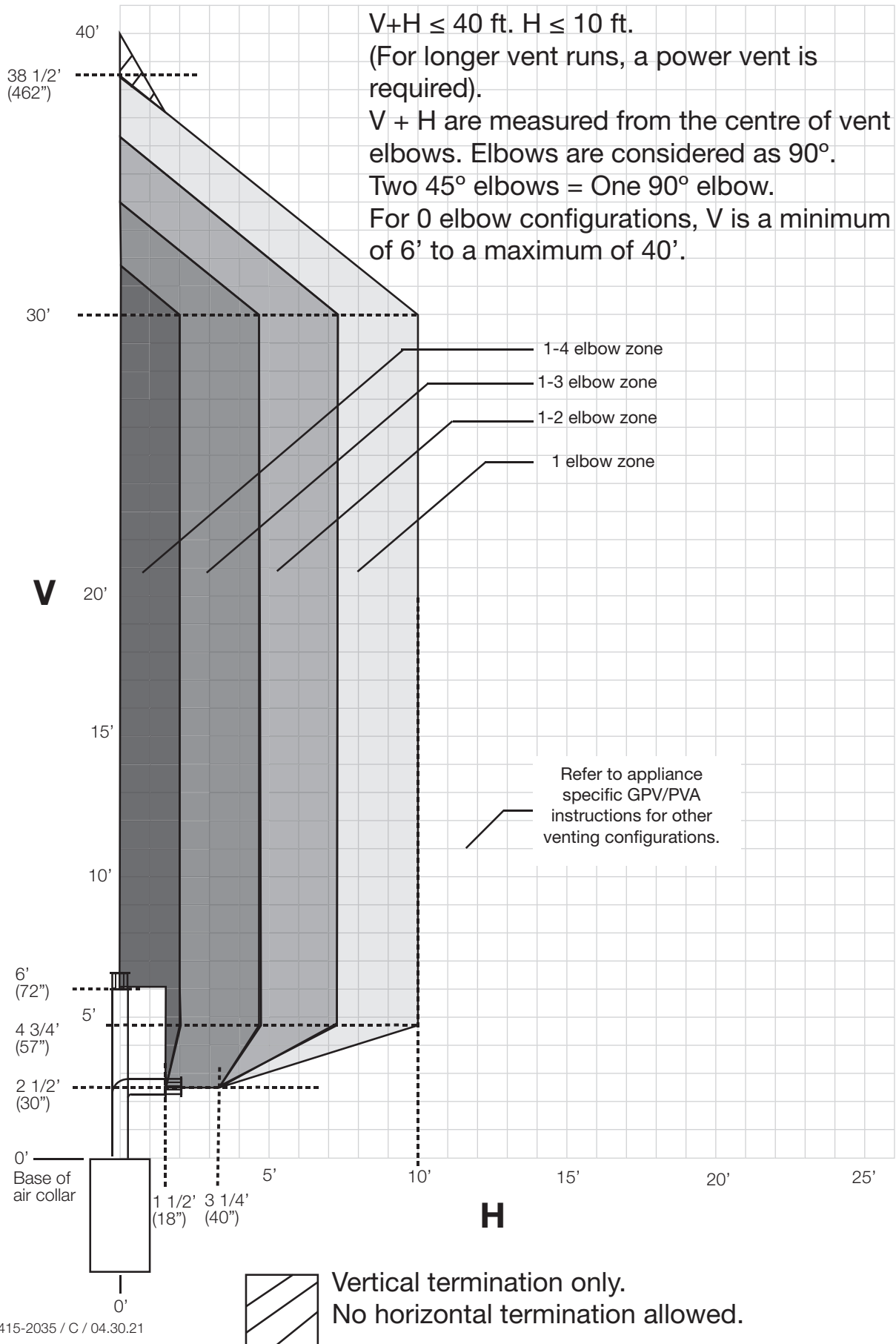

3.6 LVX50-1 / LVX62-1 venting configurations

(PROPANE ONLY)

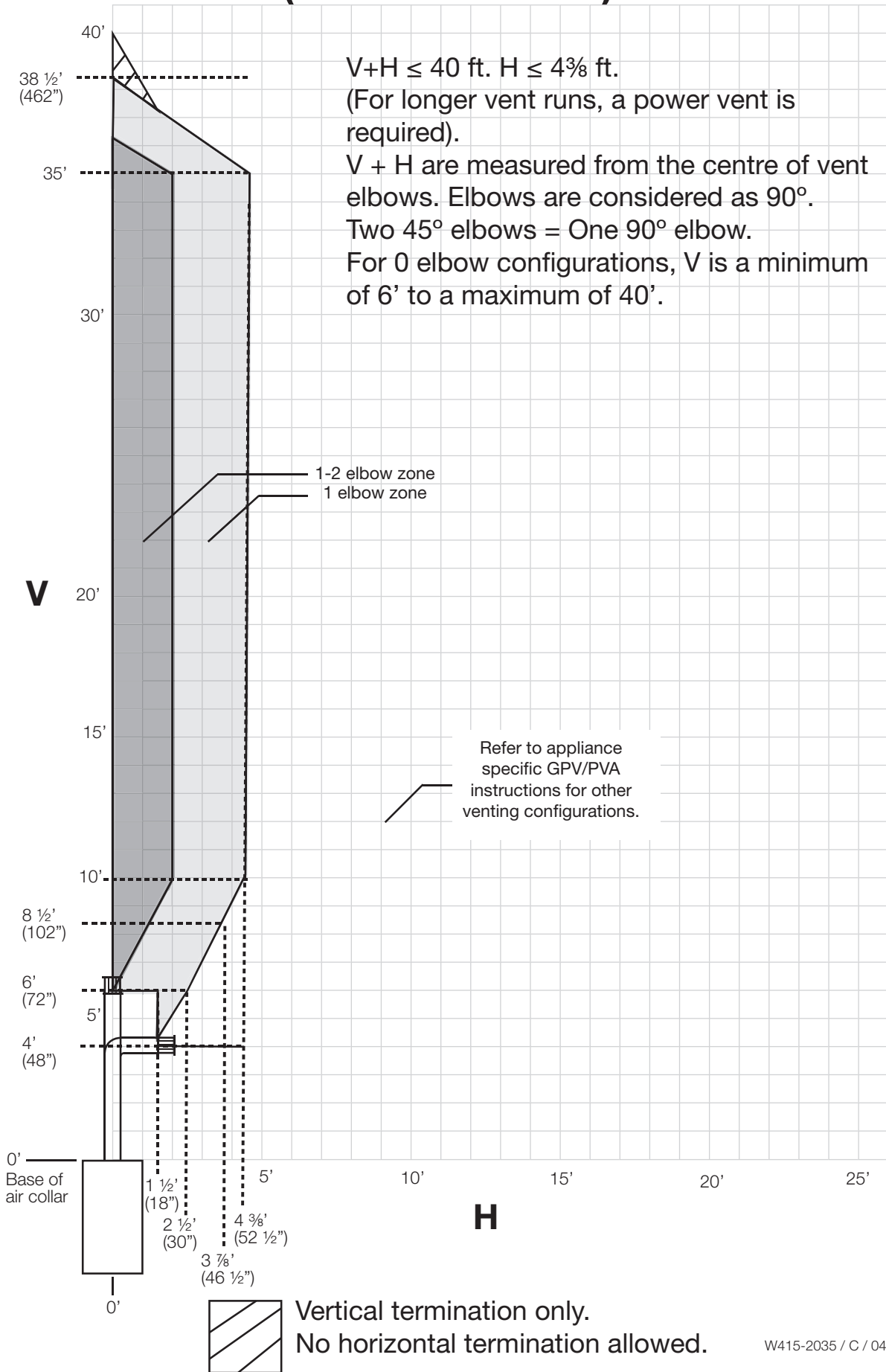

BN minimum venting requirements - propane

3.7 LVX74-1 venting configurations

(PROPANE ONLY)

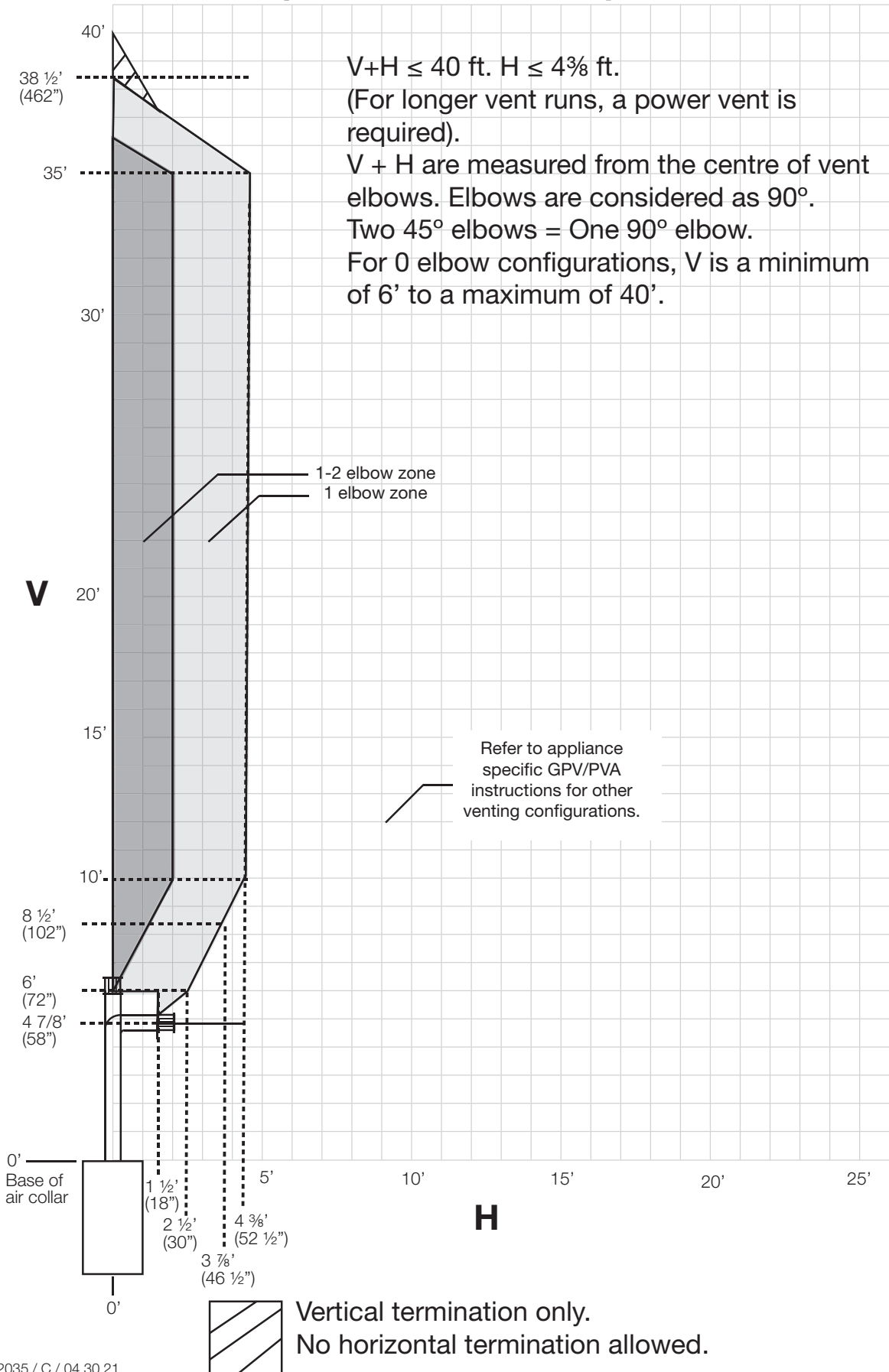

! WARNING

- Do **NOT** cover or place any items in the **Dynamic Heat Control™** air outlet. Failure to comply with these instructions will create a fire hazard.
- Ensure air flow within the air passage is not restricted in any way with the exception of approved venting.

Read Dynamic Heat Control™ section before proceeding.

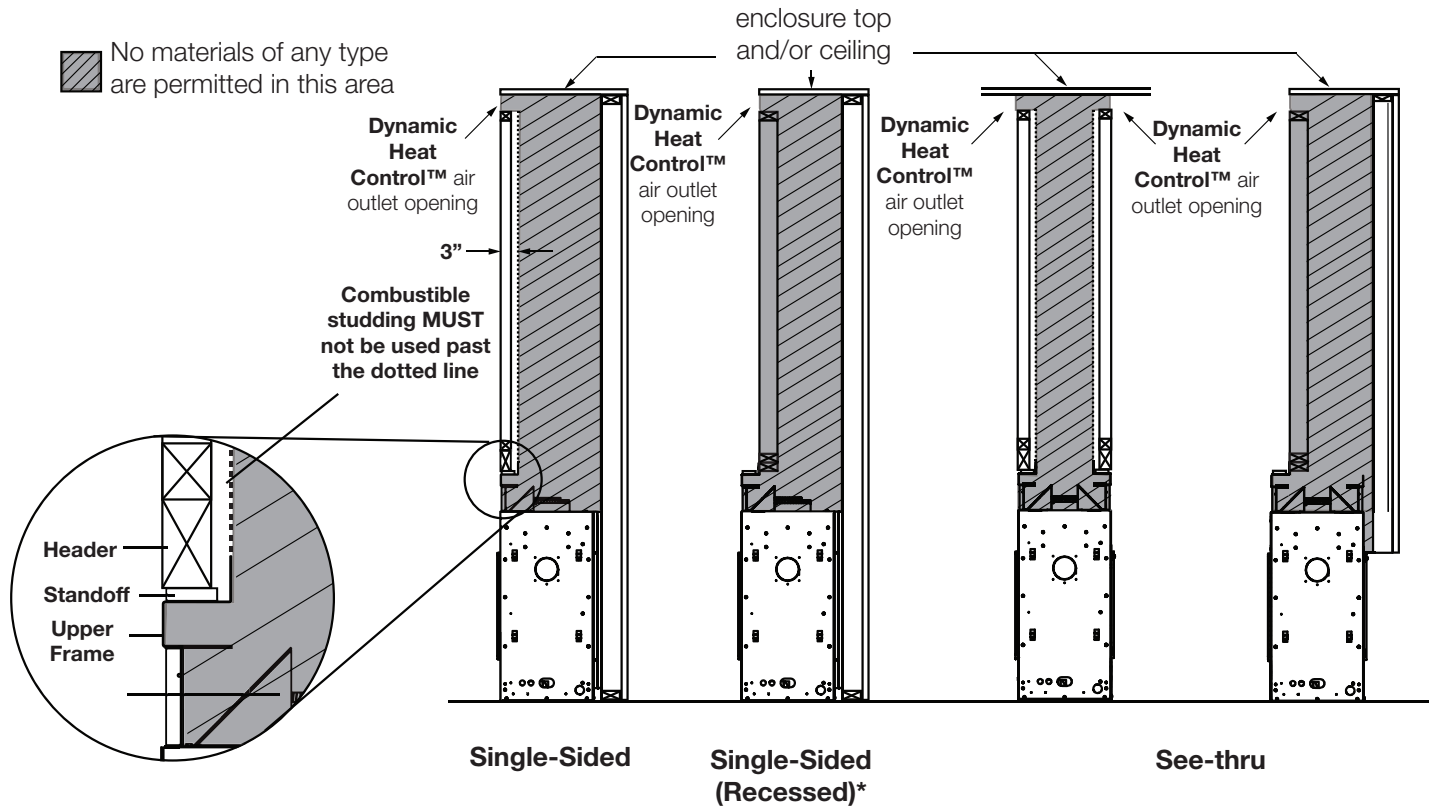

*Restrictions also apply to see-thru when one or more recess is used.

Air flow in the shaded area **must** not be restricted in any way with the exception of an approved appliance vent system. No other items are allowed in this area.

Shaded framing **must** use non-combustible materials. No combustible materials allowed in this area or the space between studs (i.e. no wiring, conduits, electrical bores, combustible framing members, AV equipment, finishing brackets, framing, etc.)

installation planning

If steel studs are used to facilitate a partial recess, they can only be used to a maximum depth of 3.5" (i.e. one stud). If the appliance is recessed further into the enclosure, the air flow will be restricted through the **DHC™** system.

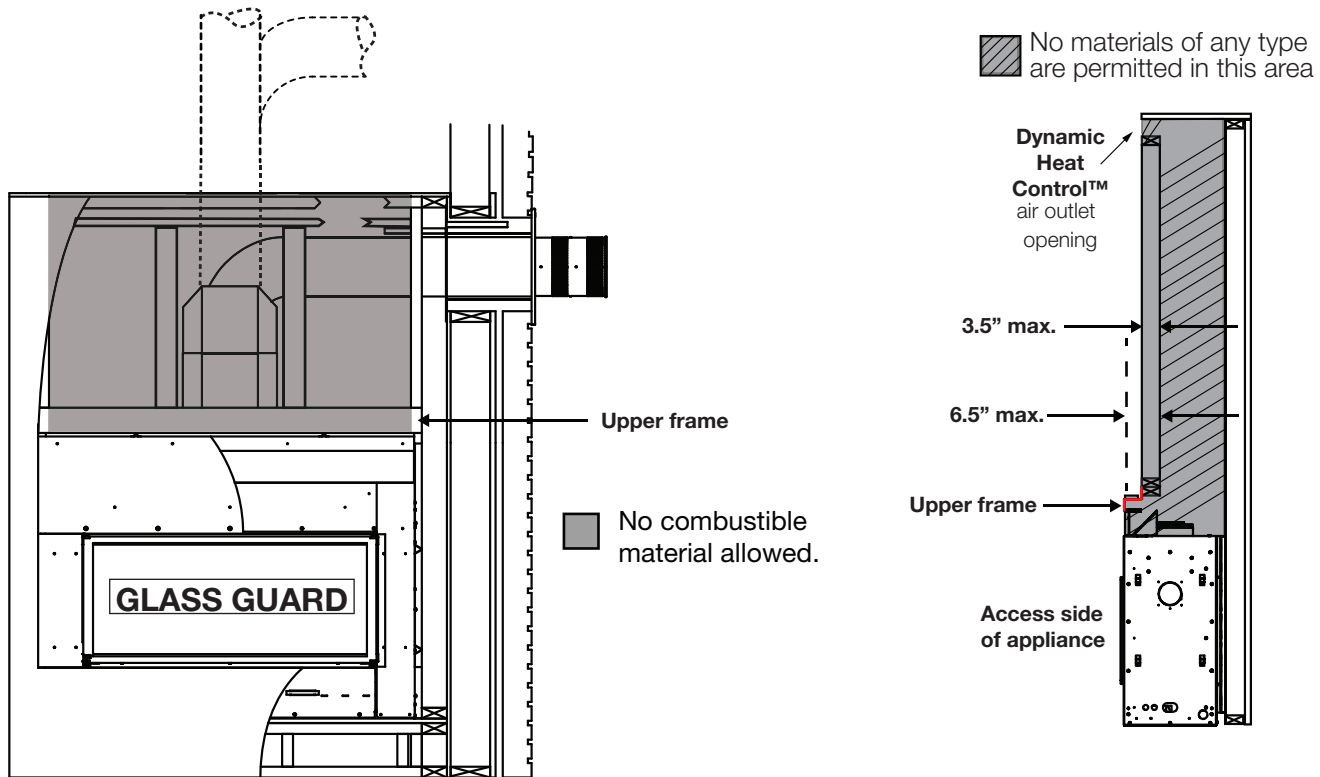

4.1 installation option 1 - open enclosure (enclosure stops short of the ceiling)

NOT Suitable for Dynamic Heat Control™ Plus

It is one option not to finish or close in the top of the enclosure to provide the necessary air circulation path for the **Dynamic Heat Control™** system. Leaving a complete air outlet opening above the enclosure has been found to be well accepted with respect to final appearance and offer minimal distraction. It also allows for efficient circulation of air within the room. This option offers the simplest method for framing and installation. (If installing **Dynamic Heat Control™ Plus**, refer to option 2 or 3 - **DHC™ Plus cannot be used with option 1**). Limit the air outlet opening height to 4" to reduce the risk of items inadvertently falling into the enclosure. **The air outlet opening must extend around the entire perimeter, or the entire front face of the enclosure, where the enclosure runs from wall to wall.**

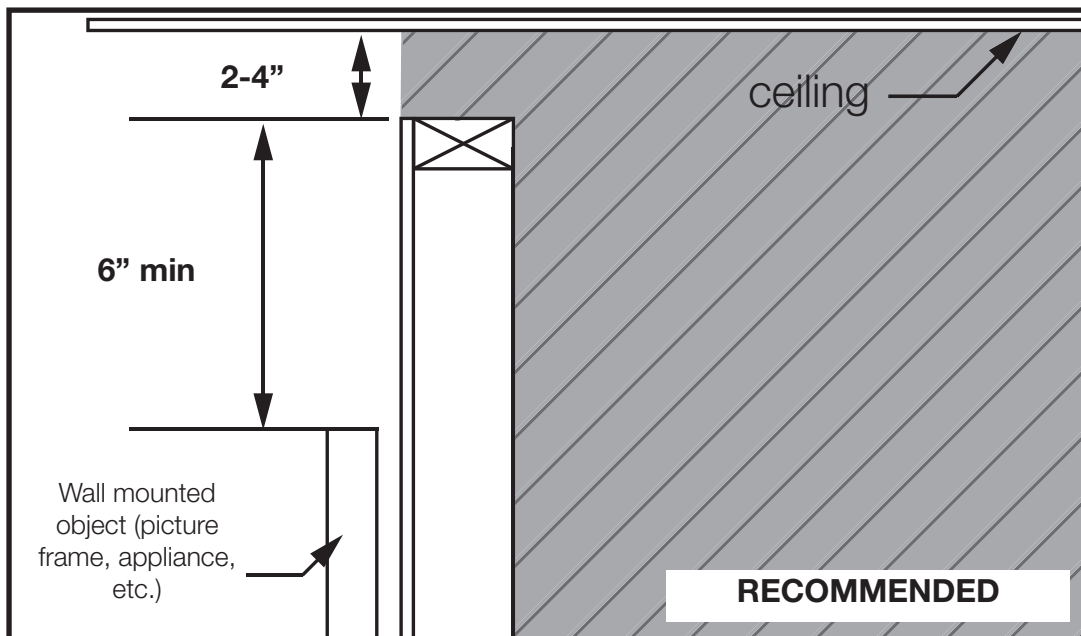
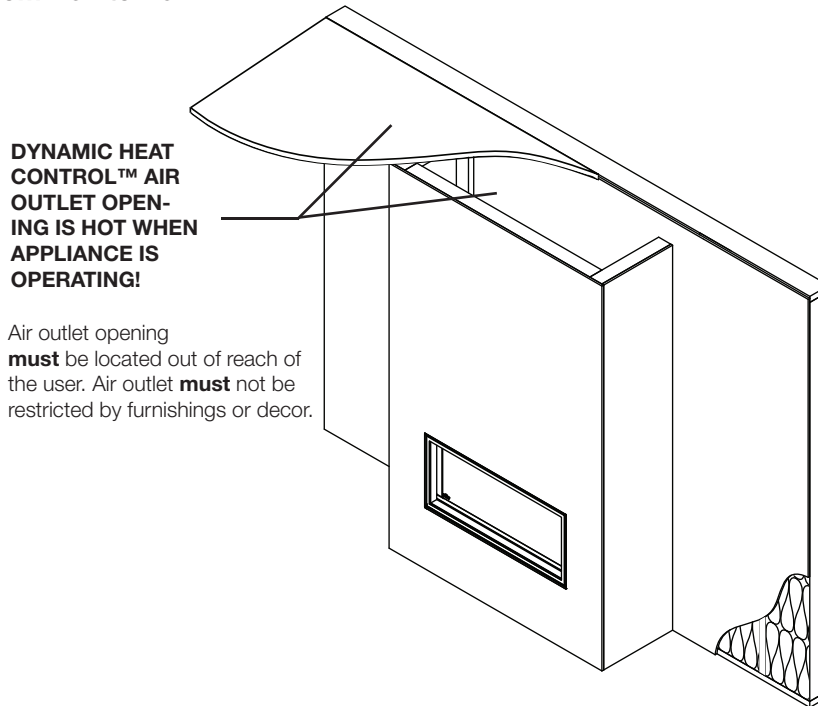

installation planning

4.2 installation option 2 - front opening

Suitable for Dynamic Heat Control™ Plus
Suitable for Dynamic Linear Trim

Minimum air outlet opening dimensions **must** be followed. The opening is required to be framed no more than 1.5" below the enclosure top (see option 2 diagram) to avoid trapping heat in the upper areas and the air outlet opening centered on the appliance center. **Framing the air outlet opening lower will overheat the appliance, the enclosure, and finishing material.**

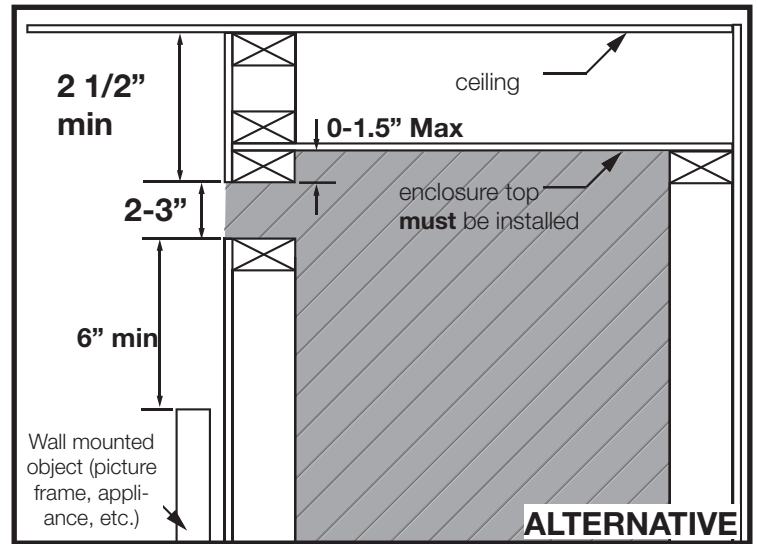
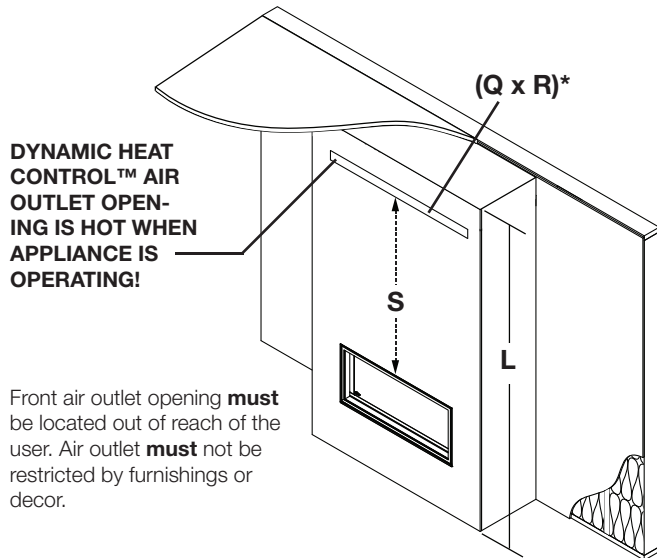

Air outlet opening is required to be centered with the appliance.

MINIMUM AIR OUTLET OPENING DIMENSIONS

	LVX38-1	LVX50-1	LVX62-1	LVX74-1
(Q x R)*	80 sq. in. minimum (Q must be 2-3")		160 sq. in. minimum (Q must be 2-3")	
S	This dimension is determined from the enclosure height (L) minus the distance to the top of the Dynamic Heat Control™ air outlet opening (0"-1.5"), height of the air opening (2"-3"), and the distance from the base of the appliance to the top of the appliance viewing area (25 11/16").			

***Free area. Any trim edging or finishing must not reduce or restrict minimum area. Grills, grates, louvres, or other unapproved covers are not permitted and will cause a fire hazard.**

4.3 installation option 3 - Rear Opening

Suitable for Dynamic Heat Control™ Plus
 Suitable for Dynamic Linear Trim

Minimum air outlet opening dimension **must** be followed. The opening is required to be framed no more than 1.5” below the enclosure top (see option 3 diagram) to avoid trapping heat in the upper areas and centered on the appliance center. **Framing the rear opening lower will overheat the appliance, the enclosure, and finishing material.**

Dynamic Heat Control™ rear air outlet opening **must** be located out of reach of the user. Opening **must** not be restricted by furnishings or decor.

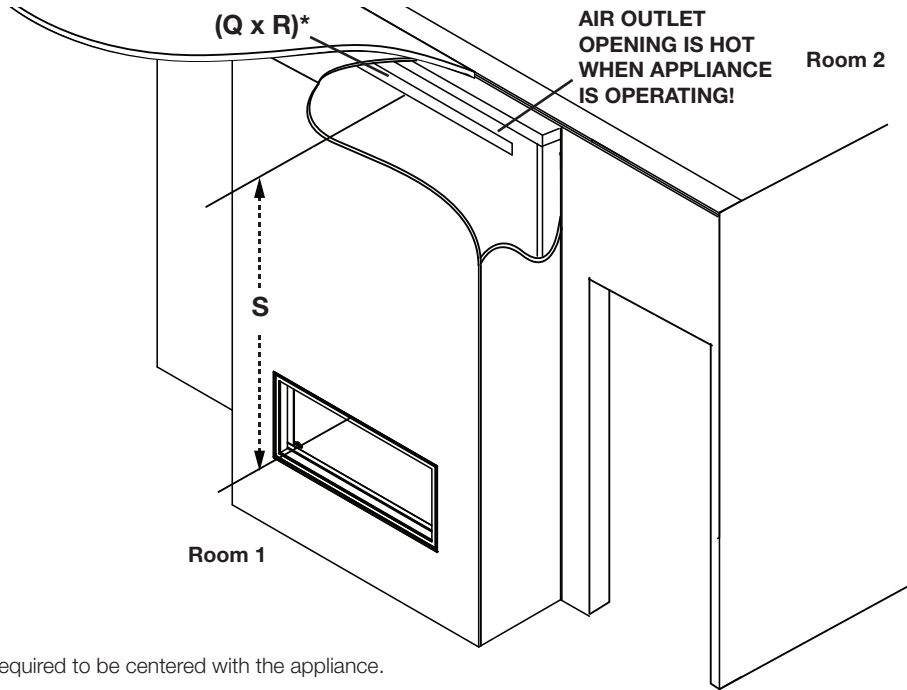

Air outlet opening is required to be centered with the appliance.

! WARNING

- When using a rear (or two-sided) air outlet opening, it is critical that the adjoining room or living spaces are in direct air communication (i.e. of an open plan configuration or connected by a permanently open doorway or archway). This prevents the appliance from being in a negative pressure more than that of the adjoining room. Failure to follow these requirements can result in reversing the Dynamic Heat Control™ air flow and will cause the appliance, glass guard assembly, and finishing materials to overheat, creating a fire hazard.

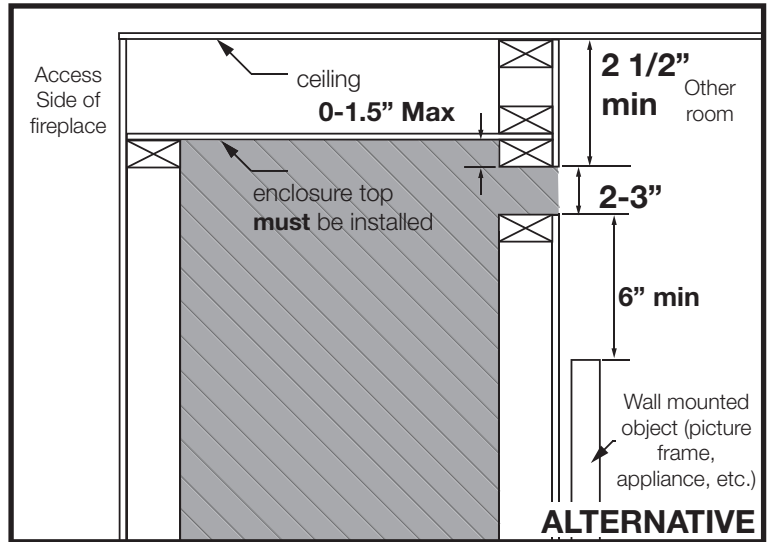

note: Increasing the air outlet opening will allow the appliance, the glass barrier, the temperatures on the surfaces above the fireplace opening, and the enclosure be at cooler temperatures. It will also allow the air to circulate more effectively in the room. **However, if the appliance is equipped with the Dynamic Heat Control™ Plus, then the opening size must be 80 sq. in. for models LVX38-1 and LVX50-1, or 160 sq. in. for models LVX62-1 and LVX74-1.**

installation planning

4.4 installation option 4 - open enclosure with hard combustible valance

NOT Suitable for Dynamic Heat Control™ Plus

Option 4 is similar to option 1 with the addition of a hard combustible valance. Minimum opening dimensions and valance dimensions **must** be followed (see option 4 diagram). **Restricting air movement within the valance area will overheat the appliance, the enclosure, and finishing material.**

NOTE: Air outlet opening must be at least continuous around the top of the enclosure for a valance to be permitted. Using the minimum air outlet opening from option 1 or 2 is not permitted and will overheat the appliance.

DYNAMIC HEAT CONTROL™ AIR OUTLET OPENING IS HOT WHEN APPLIANCE IS OPERATING!

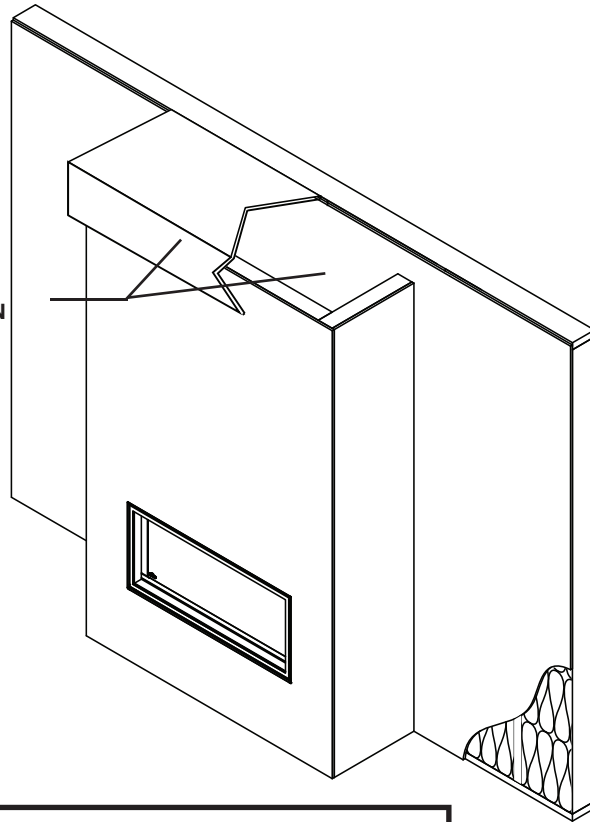

Air outlet opening must be located out of reach of the user.
Air outlet **must** not be restricted by furnishings or decor.

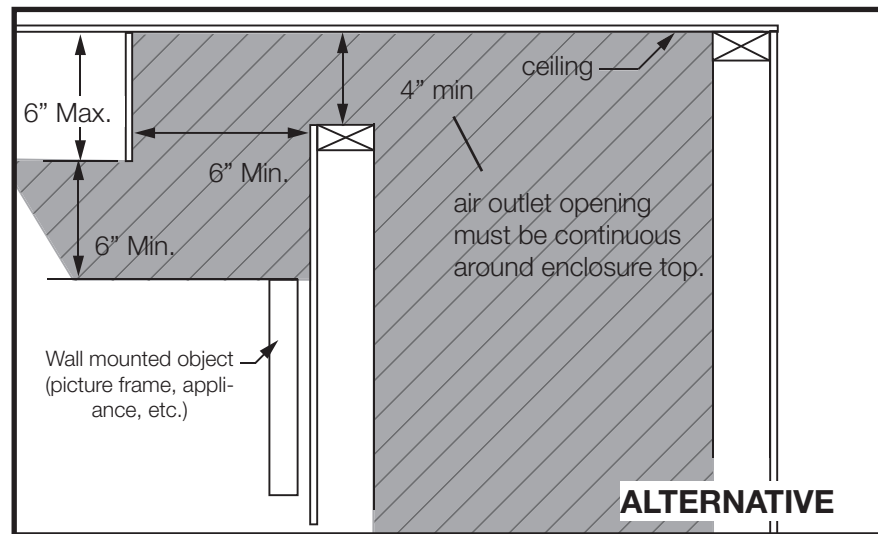

ABSOLUTELY NO OBSTRUCTION OR RESTRICTION ALLOWED IN THE ENTIRE SHADED AREA WITH THE EXCEPTION OF APPROVED VENTING

5.0 rough framing - before appliance installation

EN

note:

When using optional finishing accessories, the framing dimensions and finishing materials may differ from what is outlined in the section below; refer to the leaflet instructions supplied in the accessory kit for specific framing and finishing specifications.

WARNING

- Risk of fire!
- In order to avoid the possibility of exposed insulation or vapour barrier coming in contact with the appliance body, it is recommended that the walls of the appliance enclosure be “finished” (i.e. drywall / sheetrock), as you would finish any other outside wall of a home. This will ensure that clearance to combustibles is maintained within the cavity.
- Do not notch the framing around the appliance stand offs. Failure to maintain air space clearance may cause over heating and fire. Prevent contact with sagging or loose insulation or framing and other combustible materials. Block opening into the chase to prevent entry of blown-in insulation. Make sure insulation and other materials are secured.
- Minimum clearance to combustibles must be maintained or a serious fire hazard could result.
- The appliance requires a minimum enclosure height. Measure from the appliance base.)
- Minimum enclosure dimensions, air passages, inlets, and outlets must be maintained.

note:

For heavier finishing materials such as marble, we recommend adding extra support to the frame. Ensure there is adequate floor support for the appliance and finishing material.

rough framing - before appliance installation

5.1 minimum framing dimensions

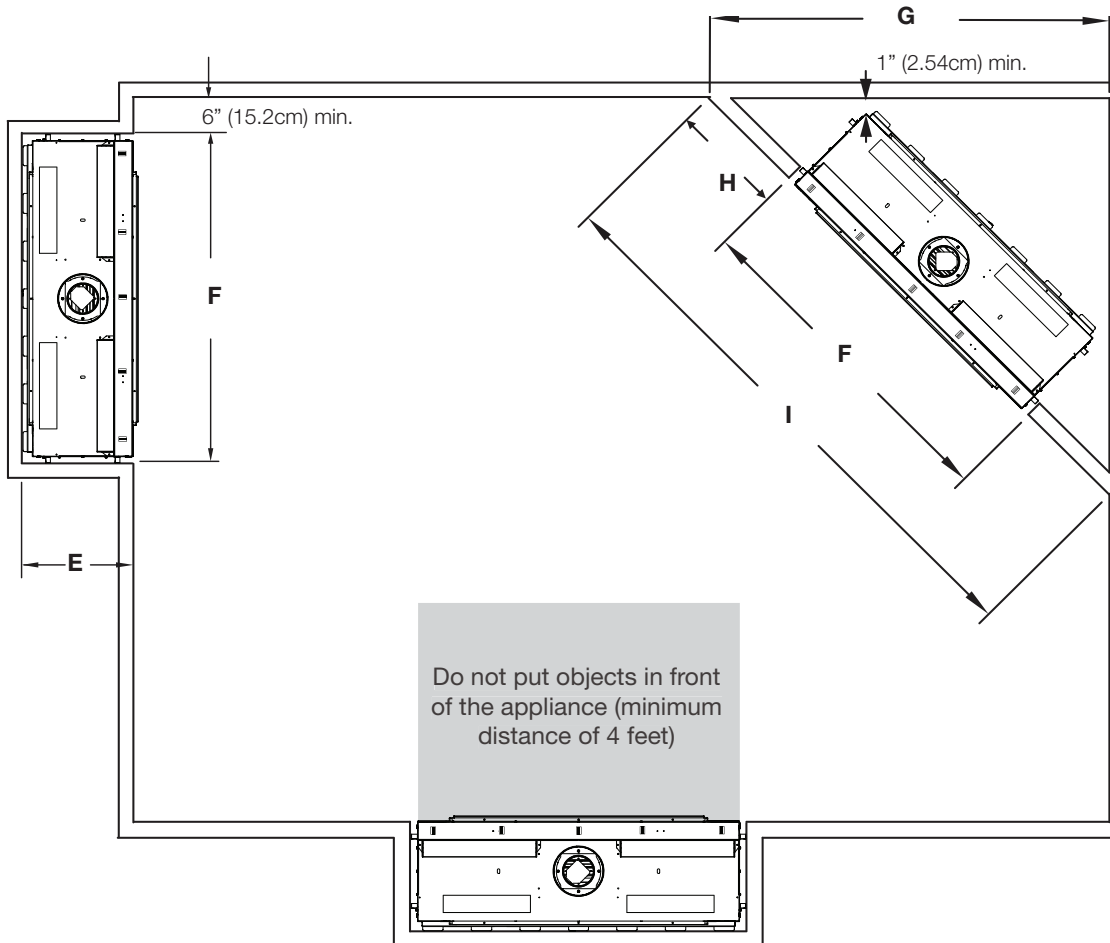

minimum framing

	LVX38-1	LVX50-1	LVX62-1	LVX74-1
*E	18" (45.7cm)**			
F	53 13/16" (136.7cm)	65 13/16" (167.2cm)	77 13/16" (197.6cm)	89 13/16" (228.1cm)
G	63 3/4" (162cm)	72 1/4" (183.5cm)	80 11/16" (205cm)	89 1/4" (226.6cm)
H	18 3/16" (46.2cm)			
I	90 3/16" (229cm)	102 3/16" (259.5cm)	114 1/8" (289.9cm)	126 1/8" (320.4cm)

Horizontal vent sections: A minimum clearance of 3" (76mm) on the top outside of the enclosure and 2" (51mm) on the sides and bottom outside of the enclosure all around the vent pipe on all horizontal runs to combustibles is required. Horizontal vent sections within enclosures require a minimum clearance of 6" (152mm) at the top of the vent pipe.

Vertical vent sections: A minimum of 1" (25mm) all around the vent pipe on all vertical runs to combustibles is required except for clearances in appliances enclosures. Vertical vent sections within enclosures require a minimum clearance of 1" (25mm) around the vent pipe.

*Single-sided model illustrated.

**Max. 21" (53.5cm)

rough framing - before appliance installation

EN

5.1.1 minimum clearance to combustible enclosures single-sided

1" [25mm] minimum all sides for sections of vertical venting.

When passing through a ceiling, use firestop spacer W500-0028 (not supplied)

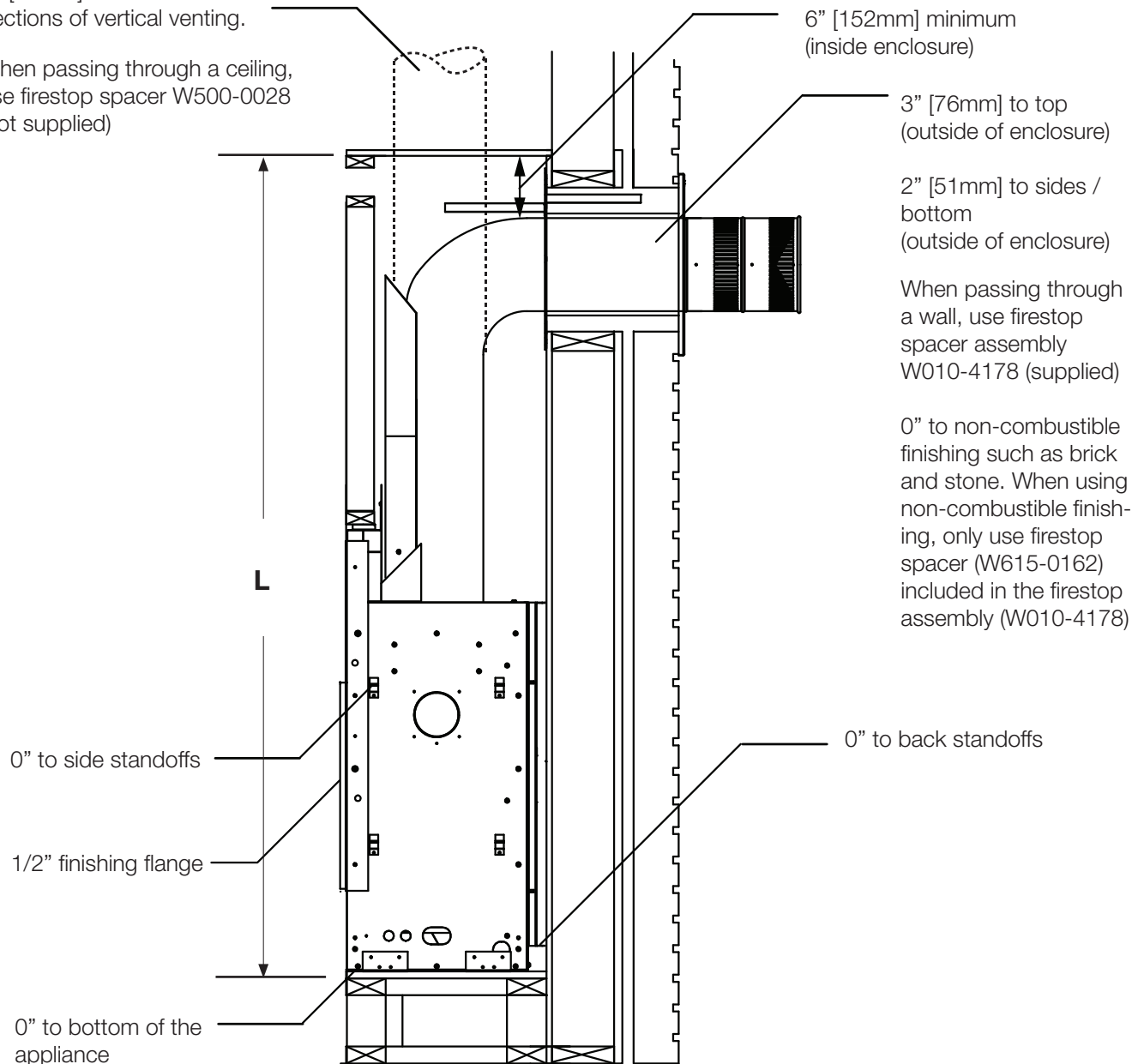

Horizontal vent sections: A minimum clearance of 3" (76mm) on the top outside of the enclosure and 2" (51mm) on the sides and bottom outside of the enclosure all around the vent pipe on all horizontal runs to combustibles is required. Horizontal vent sections within enclosures require a minimum clearance of 6" (152mm) at the top of the vent pipe.

Vertical vent sections: A minimum of 1" (25mm) all around the vent pipe on all vertical runs to combustibles is required except for clearances in appliances enclosures. Vertical vent sections within enclosures require a minimum clearance of 1" (25mm) around the vent pipe.

note:

The LVX series requires a minimum enclosure height, as illustrated (dimension L), measured from the bottom of the appliance. For temperature requirements, this area must be left unobstructed. Some venting configurations that require more vertical rise will require a larger enclosure to provide minimum vertical clearance between vent pipes and combustibles.

minimum clearance

Ref	LVX38-1	LVX50-1	LVX62-1	LVX74-1
L	73" (185.4cm)		91" (231.1cm)	

rough framing - before appliance installation

see-thru

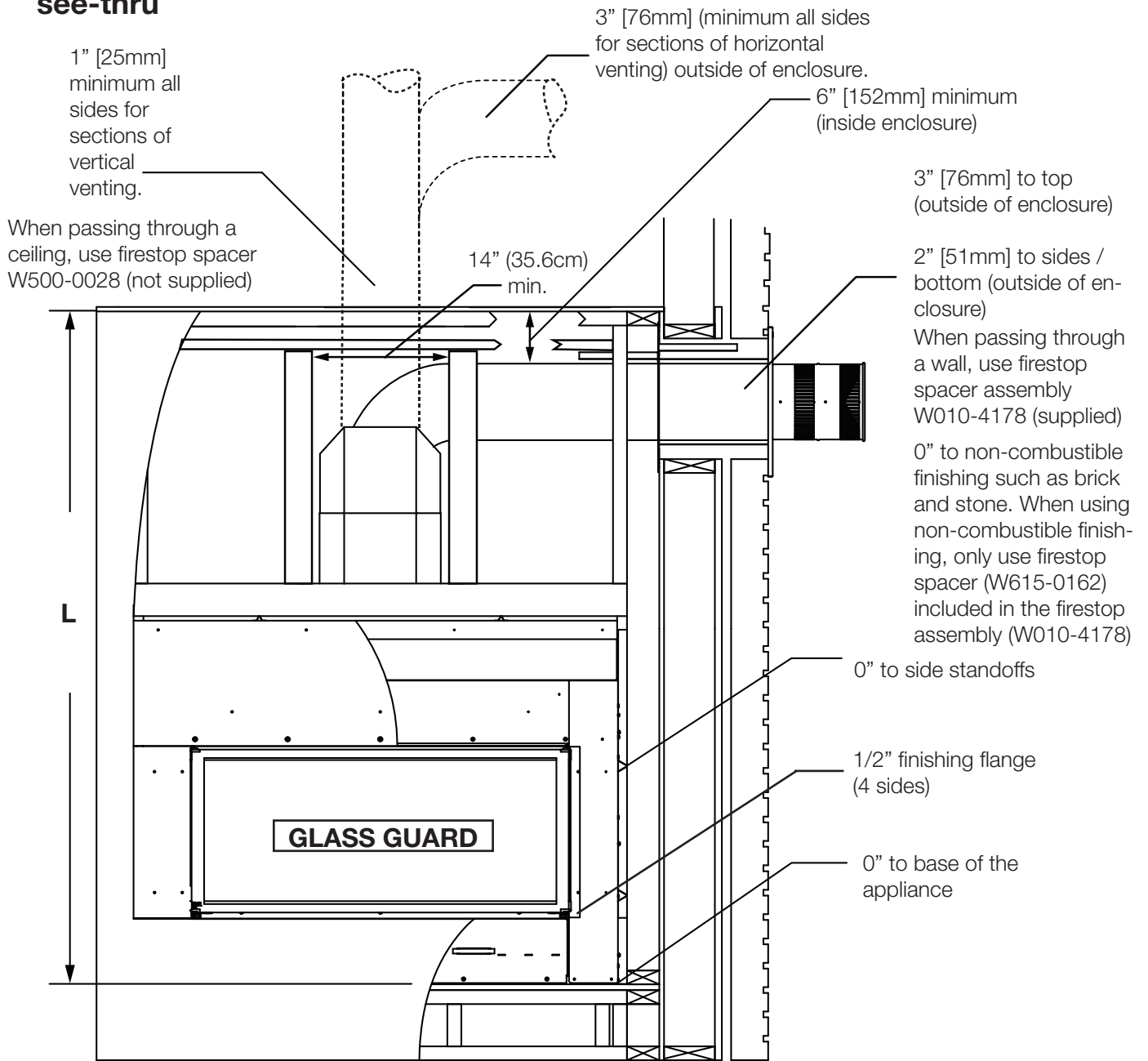

Horizontal vent sections: A minimum clearance of 3" (76mm) on the top outside of the enclosure and 2" (51mm) on the sides and bottom outside of the enclosure all around the vent pipe on all horizontal runs to combustibles is required. Horizontal vent sections within enclosures require a minimum clearance of 6" (152mm) at the top of the vent pipe.

Vertical vent sections: A minimum of 1" (25mm) all around the vent pipe on all vertical runs to combustibles is required except for clearances in appliances enclosures. Vertical vent sections within enclosures require a minimum clearance of 1" (25mm) around the vent pipe.

minimum clearance

Ref	LVX38-1	LVX50-1	LVX62-1	LVX74-1
L	73" (185.4cm)		91" (231.1cm)	

note:

The LVX series requires a minimum enclosure height, as illustrated (dimension L), measured from the bottom of the appliance. For temperature requirements, this area must be left unobstructed. Some venting configurations that require more vertical rise will require a larger enclosure to provide minimum vertical clearance between vent pipes and combustibles.

rough framing - before appliance installation

EN

Before framing your appliance, determine vent requirements before deciding the final location of the appliance. After rough framing, place the appliance in its final position.

single-sided

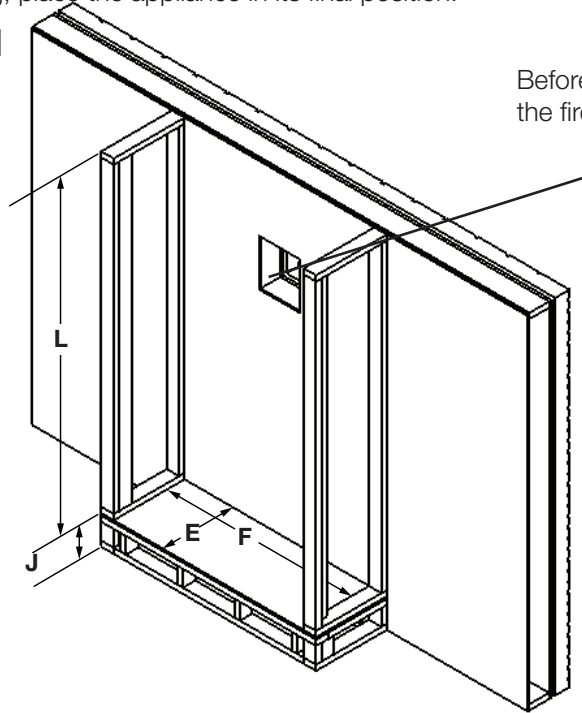

Before framing the appliance, ensure to install the firestop first.

note:

The LVX series requires a minimum enclosure height, as illustrated (dimension L), measured from the bottom of the appliance. For temperature requirements, this area must be left unobstructed. Some venting configurations that require more vertical rise will require a larger enclosure to provide minimum vertical clearance between vent pipes and combustibles.

Ref	LVX38-1	LVX50-1	LVX62-1	LVX74-1
E*	18" (45.7cm)			
F	53 13/16" (136.7cm)	65 13/16" (167.2cm)	77 13/16" (197.6cm)	89 13/16" (228.1cm)
J	Optional - Appliance does not need to be elevated above floor			
L	73" (185.4cm)		91" (231.1cm)	

*Maximum of 21" (53.5cm)

see-thru

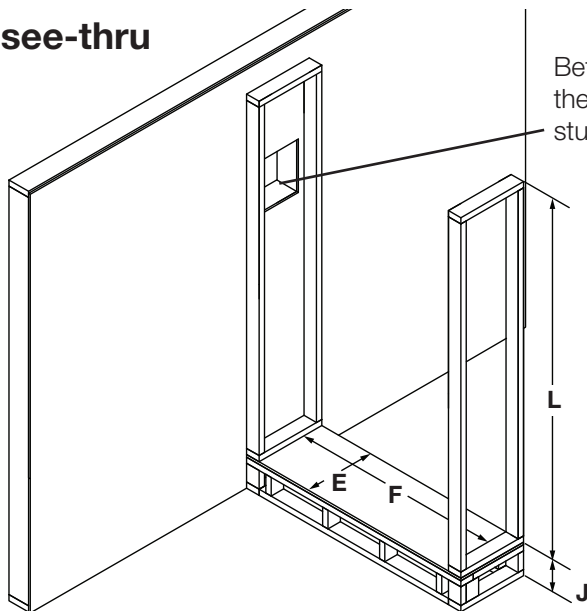

Before framing the appliance, ensure to install the firestop first as it will not fit between the studs if installed after framing.

note:

The LVX series requires a minimum enclosure height, as illustrated (dimension L), measured from the bottom of the appliance. For temperature requirements, this area must be left unobstructed. Some venting configurations that require more vertical rise will require a larger enclosure to provide minimum vertical clearance between vent pipes and combustibles.

Ref	LVX38-1	LVX50-1	LVX62-1	LVX74-1
E*	16 3/16" (41.1cm)			
F	53 13/16" (136.7cm)	65 13/16" (167.2cm)	77 13/16" (197.6cm)	89 13/16" (228.1cm)
J	Optional - Appliance does not need to be elevated above floor			
L	73" (185.4cm)		91" (231.1cm)	

*Maximum of 21" (53.5cm)

W415-2035 / C / 04.30.21

6.0 venting installation

⚠ WARNING

- Ensure to unpack all loose materials from inside the firebox prior to connecting the gas and electrical supply
- **If your appliance is supplied with a remote, ensure the remote receiver is in the "OFF" position prior to connecting the gas and electrical supply to the appliance.**
- For safe and proper operation of the appliance, follow the venting instructions exactly.
- **The appliance exhaust flue collar must be sealed using Mill Pac.** All exhaust and intake vent pipe joints must be sealed using red RTV high temp silicone sealant (W573-0002) (not supplied) or black high temp Mill Pac (W573-0007) (not supplied).
- If using pipe clamps to connect rigid vent components, a minimum of 3 screws must also be used to ensure the connection cannot slip off.
- Do not clamp the flexible vent pipe.
- Risk of fire, explosion, or asphyxiation. Improper support of the entire venting system may allow vent to sag and separate. Use vent run supports and connect vent sections per installation instructions.
- Risk of fire, do not allow loose materials or insulation to touch the vent pipe. Remove insulation to allow for the installation of the attic shield and to maintain clearances to combustibles.
- Do not fill the space between the vent pipe and enclosure with any type of material. Do not pack insulation or combustibles between ceiling firestops. Always maintain specified clearances around venting and firestop systems. Install wall shields and firestops as specified. Failure to keep insulation or other materials away from vent pipe may cause fire.
- **For gas stoves only:** If the appliance is installed directly on carpeting, vinyl tile, or other combustible material other than wood flooring, the appliance shall be installed on a metal or wood panel extending the full width and depth, unless otherwise tested.

For optimum performance, it is recommended that all horizontal runs have a minimum of 1/4" (6mm) rise per foot using flexible venting.

note:

The vent shield is telescopic and must be adjusted to shield the first 30" (76.2cm) of vertical vent when applicable.

For vent shield installation, see section "vent shield installation"

Power vent system available with reduced vent pipe diameter and longer vent runs.

6.1 firestop spacer assembly

1. Install standoffs onto the firestop spacer (**Figure 1**).
2. Install one vent shield onto the standoff on one side of the firestop spacer (**Figure 2**).
3. Install the other vent shield on the opposite side of the firestop spacer (**Figure 3**).



#1 (x18)

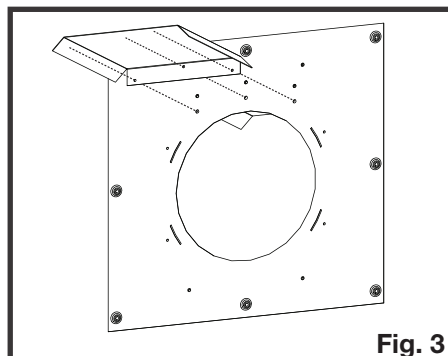
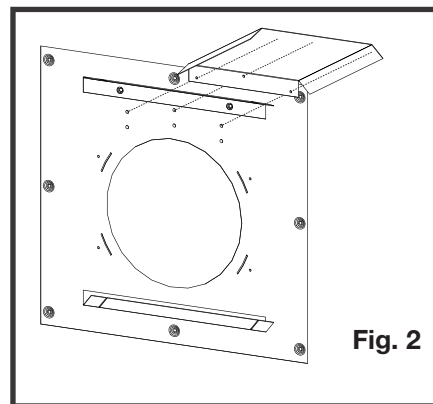
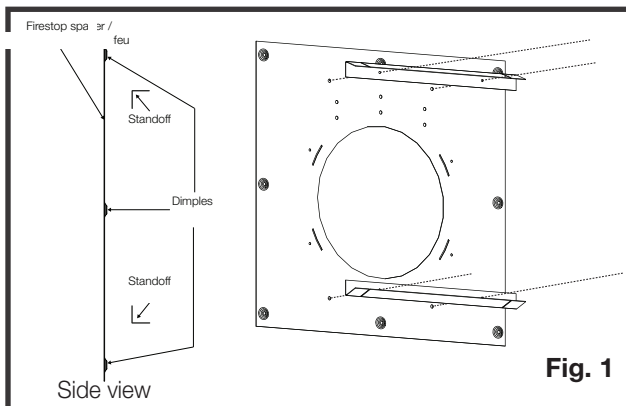

- 1. Roll the vent sleeve as shown and ensure to clip the ends together (Figure 4).
- 2. Ensure both ends line up and secure ends with clip and fasteners (Figure 5).

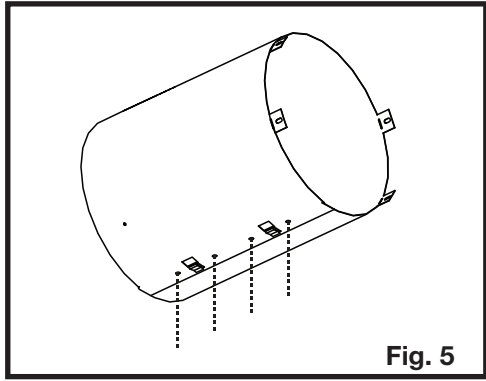
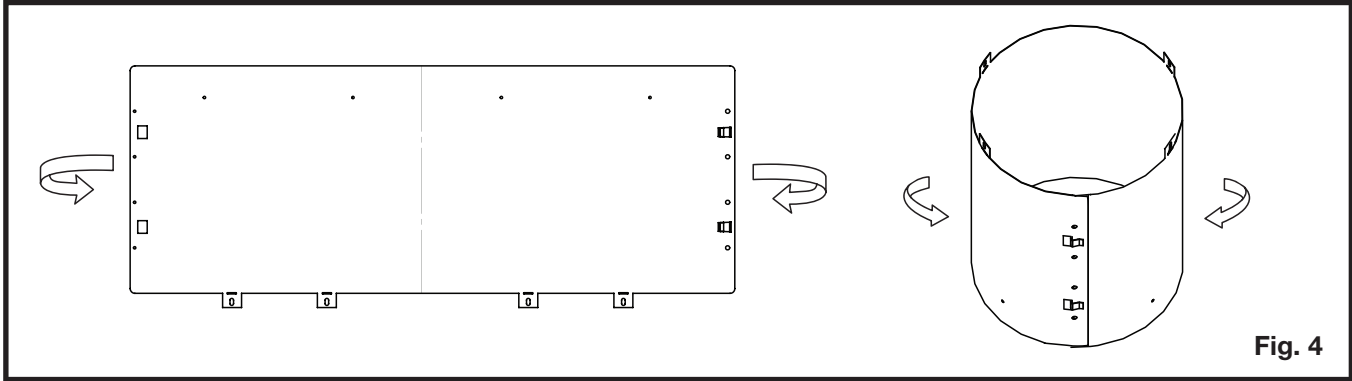

- 3. Insert the vent sleeve tabs into the firestop spacer slots then bend the tabs over to secure to the firestop spacer along with 4 supplied fasteners (Figure 6).

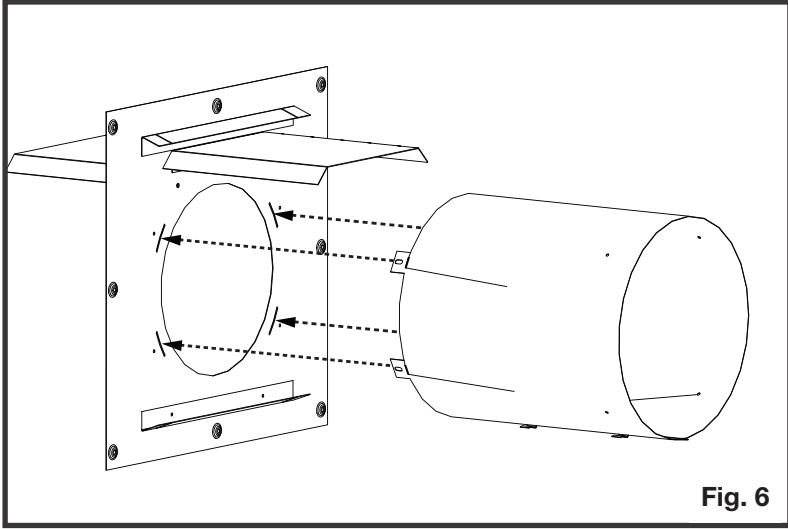

note:
Note orientation of dimples and standoffs.

venting installation

6.2 horizontal installation

! WARNING

- The firestop assembly must be installed with the vent shield to the top.
- Terminals must not be recessed into a wall or siding more than the depth of the return flange of the mounting plate.

This application occurs when venting through an exterior wall. Having determined the correct height for the air terminal location, cut and frame a hole in the exterior wall, as illustrated, to accommodate the firestop assembly. Dry fit the firestop assembly before proceeding to ensure the brackets on the rear surface fit to the inside surface of the horizontal framing.

The length of the vent shield may be cut shorter for combustible walls that are less than 8 1/2" (215.9mm) thick but the vent shield must extend the full depth of the combustible wall.

note:

Do not fill the air space between the firestop spacer and the exterior wall with any type of insulating material (i.e. spray foam).

- Apply a bead of caulking (not supplied) around the outer edge of the hole of the firestop assembly, fit the firestop assembly to the hole and secure using 4 screws.
- Once the vent pipe is installed in its final position, apply red RTV silicone (W573-0002) (not supplied) between the pipe and the firestop.

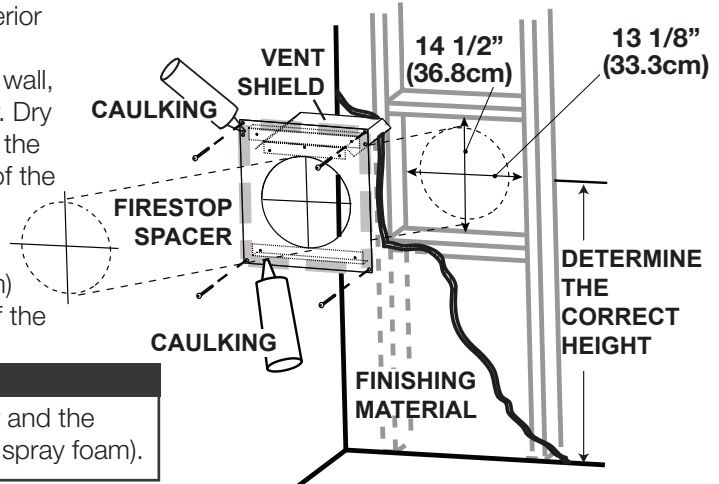

note:

The above is for illustration purposes only. Vents do not always pass through center of frame.

6.3 vertical installation

This application occurs when venting through a roof. Installation kits for various roof pitches are available from your authorized dealer / distributor. See the "accessories" section to order specific kits required.

- Determine the air terminal location, cut and frame a square opening, as illustrated, in the ceiling and the roof to provide the minimum 1" (25mm) clearance between the vent pipe and any combustible material. Try to center the vent pipe location midway between two joists to prevent having to cut them. Use a plumb bob to line up the center of the openings. A vent pipe shield will prevent any materials such as insulation, from filling up the 1" (25mm) air space around the pipe. Nail headers between the joist for extra support.
- Apply a bead of caulking (not supplied) to the framework or to the Wolf Steel vent pipe shield plate or equivalent (in the case of a finished ceiling), and secure over the opening in the ceiling. A firestop must be placed on the bottom of each framed opening in a roof or ceiling that the venting system passes through. Apply a bead of caulking all around and place a firestop spacer over the vent shield to restrict cold air from being drawn into the room or around the fireplace. Ensure that both spacer and shield maintain the required clearance to combustibles. Once the vent pipe is installed in its final position, apply red RTV silicone (W573-0002) (not supplied) between the pipe and the firestop assembly.
- In the attic, slide the vent pipe collar down to cover up the open end of the shield and tighten. This will prevent any materials, such as insulation, from filling up the 1" (25mm) air space around the pipe.

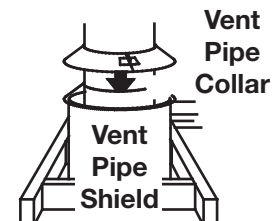
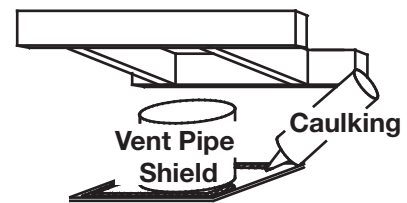
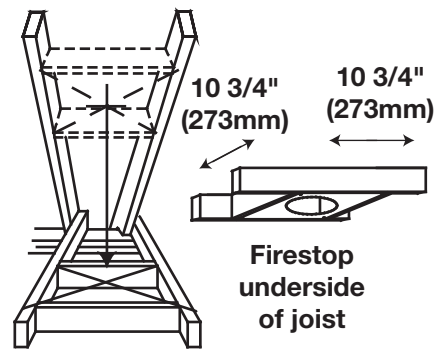

6.4 using flexible vent components

! WARNING

- Do not allow the inner flex pipe to bunch up on horizontal or vertical runs and elbows. Keep it pulled tight.
- Spacers are attached to the inner flex pipe at predetermined intervals to maintain an even air gap to the outer flex pipe. This gap is required for safe operation. A spacer is required at the start, middle, and end of each elbow to ensure this gap is maintained. These spacers must not be removed.

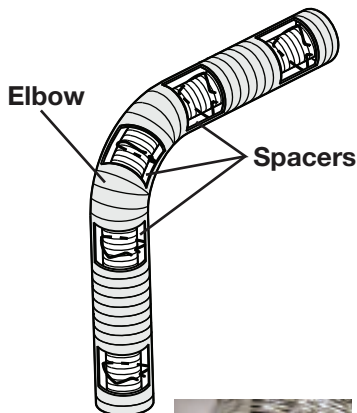

For safe and proper operation of the appliance, follow the venting instructions exactly.

The vent system must be supported approximately every 3 feet (0.9m) for both vertical and horizontal runs. Use Wolf Steel Ltd. support ring assembly or equivalent noncombustible strapping to maintain the minimum clearance to combustibles for both vertical and horizontal runs.

All inner flex pipe and outer flex pipe joints may be sealed using high temperature red RTV silicone W573-0002 (not supplied) or the high temperature sealant W573-0007 Mill Pac (not supplied). However, the high temperature sealant W573-0007 Mill Pac (not supplied) must be used on the joint connecting the inner flex pipe and the exhaust flue collar.

Use only approved flexible vent pipe kits marked:



“Wolf Steel Approved Venting” or “E2” as identified by the stamp only on the flex pipes.

6.4.1 horizontal air terminal installation

- Stretch the inner flex pipe to the required length taking into account the additional length needed for the finished wall surface. Apply a heavy bead of the red RTV silicone (W573-0002) (not supplied) to the inner sleeve of the air terminal. Slip the vent pipe a minimum of 2" (50.8mm) over the inner sleeve of the air terminal and secure with a minimum of 3 screws.
- Using the outer flex pipe, slide over the outer combustion air sleeve of the air terminal and secure with a minimum of 3 screws. Seal using red RTV silicone (W573-0002) (not supplied).
- Insert the vent pipes through the firestop maintaining the required clearance to combustibles. Holding the air terminal (lettering in an upright, readable position), secure to the exterior wall and make weather tight by sealing with caulking (not supplied).
- If more vent pipe needs to be used to reach the fireplace, couple them together, as illustrated. The vent system must be supported approximately every 3 feet (0.9m) for both vertical and horizontal runs. Use non-combustible strapping to maintain the minimum clearance to combustibles.

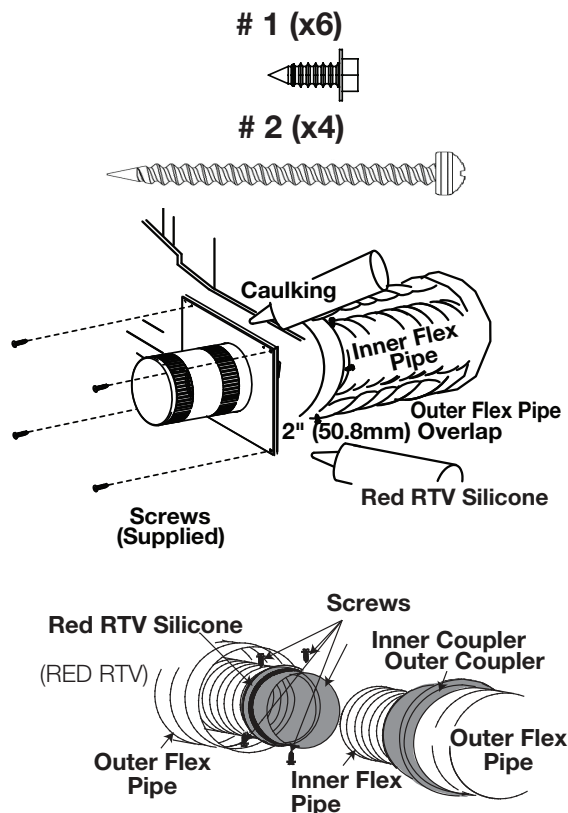

The air terminal mounting plate may be recessed into the exterior wall or siding no greater than the depth of its return flange.

venting installation

6.5 vertical air terminal installation

! WARNING

- Maintain a minimum 2" (51mm) space between the air inlet base and the storm collar.

note:

Fastening hardware provided with appropriate roof terminal and liner kits.

- Fasten the roof support to the roof using 6 screws. The roof support is optional. In this case, the venting is to be adequately supported using either an alternate method suitable to the authority having jurisdiction or the optional roof support.
- Stretch the inner flex pipe to the required length. Slip the inner flex pipe a minimum of 2" (51mm) over the inner pipe of the air terminal connector and secure with a minimum of three screws, when 4/7, 5/8 and 3/5 venting is used and a minimum of six screws when using 8/10 or 8/11 venting. Seal using a heavy bead of red RTV silicone sealant (W573-0002) (not supplied).
- Repeat using the outer flex pipe, using a heavy bead of red RTV silicone sealant (W573-0002) (not supplied) and a minimum of three screws, when 4/7, 5/8 and 3/5 venting is used and a minimum of six screws when using 8/10 or 8/11 venting.
- Thread the air terminal connector / vent pipe assembly down through the roof. The air terminal must be positioned vertically and plumb. Attach the air terminal connector to the roof support, ensuring that the top of the air terminal is 16" (40.6cm) above the highest point that it penetrates the roof.
- Remove nails from the shingles, above and to the sides of the air terminal connector. Place the flashing over the air terminal connector leaving a min. 3/4" (19mm) of the air terminal connector showing above the top of the flashing. Slide the flashing underneath the sides and upper edge of the shingles. Ensure that the air terminal connector is properly centered within the flashing, giving a 3/4" (19mm) margin all around. Fasten to the roof. Do not nail through the lower portion of the flashing. Make weather-tight by sealing with caulking. Where possible, cover the sides and top edges of the flashing with roofing material.
- Aligning the seams of the terminal and air terminal connector, place the terminal over the air terminal connector making sure the vent pipe goes into the hole in the terminal. Secure with a minimum of three screws, when 4/7, 5/8 and 3/5 venting is used and a minimum of six screws when using 8/10 or 8/11 venting.
- Apply a heavy bead of weatherproof caulking 2" (51mm) above the flashing. Install the storm collar around the air terminal and slide down to the caulking. Tighten to ensure that a weather-tight seal between the air terminal and the collar is achieved.
- If more vent pipe needs to be used to reach the appliance, see "**horizontal air terminal installation**" section.

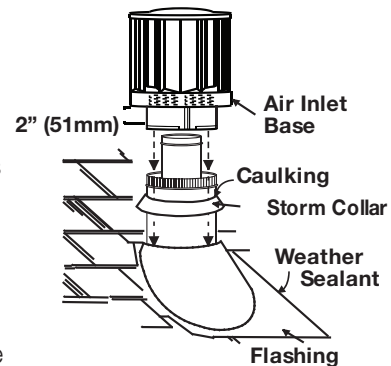
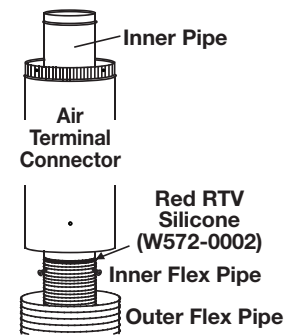
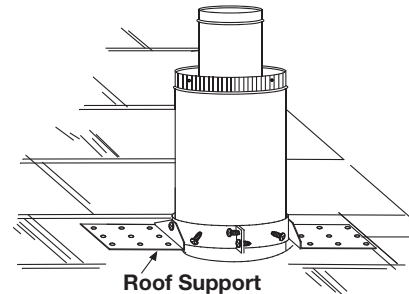

6.5.1 appliance vent connection

- Install the inner flex pipe to the appliance. Secure with a minimum of three screws when installing 3"/5", 4"/7" or 5"/8" venting, or six screws when installing 8"/10" or 8"/11" venting. Seal the joint and screw holes using Mill Pac sealant (W573-0007) (not supplied).
- Install the outer flex pipe to the appliance. Secure with a minimum of three screws when installing 3"/5", 4"/7" or 5"/8" venting, or six screws when installing 8"/10" or 8"/11" venting. Seal the joints using high temperature red RTV silicone (W573-0002) (not supplied).

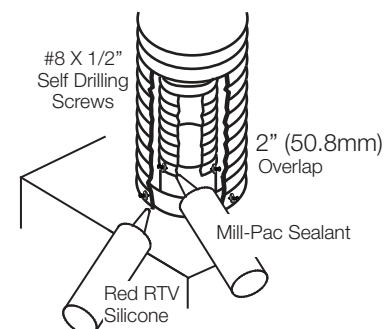

6.6 restricting vertical vents

Vertical installations may display a very active flame. If this appearance is not desirable, the exhaust outlet may be restricted with a Wolf Steel approved restrictor kit. This kit is not recommended for short vertical vent runs.

Depending on the model and/or year of your appliance, mounting holes may not exist.

6.6.1 LVX38-1 / LVX50-1

- A. If mounting holes exist, remove the screws from the firebox top, align the restrictor plate as illustrated and secure.
- B. If mounting holes do not exist, align the restrictor plate as illustrated and secure using the two screws (supplied).
- C. Ensure the plate will pivot at the slot up into the exhaust outlet.
- D. Depending on the amount of restriction desired, the restrictor plate can be left flat for most restriction or bent up for varying degrees of restriction.

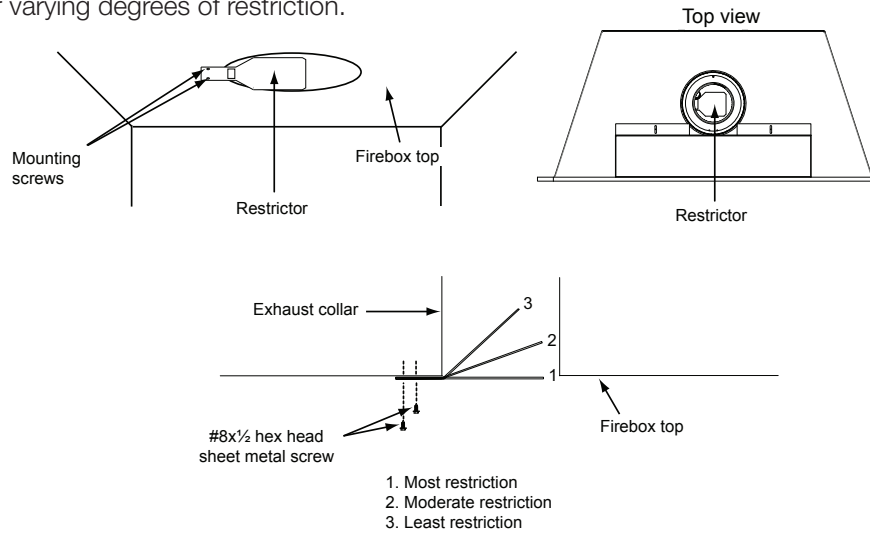

6.6.2 LVX62-1 / LVX74-1

- A. Secure 5" restrictor to mounting plate using 2 screws (supplied).
- B. Remove baffle by removing 1 screw from firebox. Set screw and baffle aside.
- C. Align mounting plate clearance holes (4) over existing screws protruding into firebox. For ease of access, ensure restrictor and mounting plate are installed with screws installed in Step A facing upwards (into exhaust collar).
- D. Install 4 self-drilling screws (supplied) (2 per side).

note:

For ease of installation, the mounting plate was designed with 2 fixed holes and 2 slotted holes.

- E. Reinstall baffle using screw removed in step B.

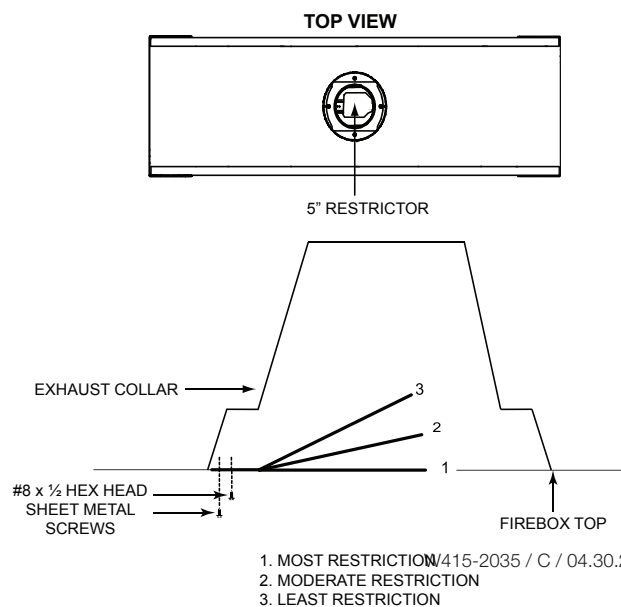
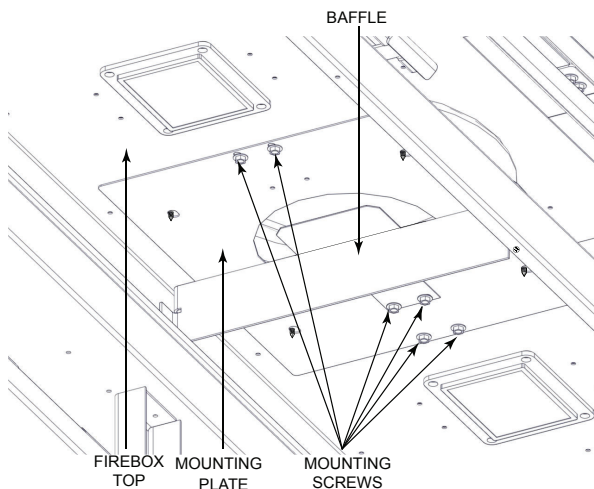

venting installation

6.7 vent shield installation

important:

For ease of installation, the front frame can be removed. The front frame must be reinstalled prior to installing the nailing tabs.

note:

The vent shield is telescopic and must be adjusted to shield the first 30" of vertical vent always used.

1. Loosen the fasteners on the vent shield assembly. DO NOT DISCARD FASTENERS (Figure 1).
2. Adjust vent shield to its maximum vertical (Figure 2).
3. Tighten the fasteners to lock the vent shield height (Figure 3).

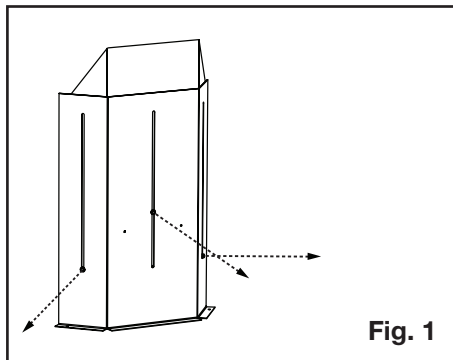

Fig. 1

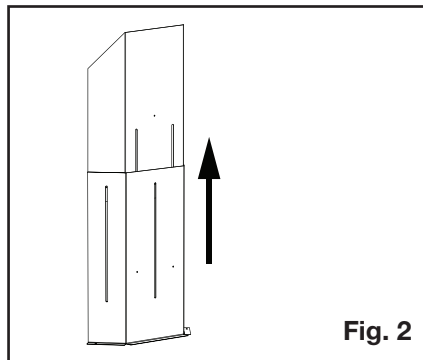

Fig. 2

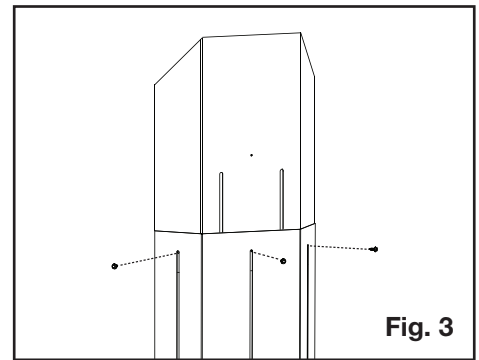

Fig. 3

4. Remove the fasteners as shown (Figure 4). DO NOT DISCARD FASTENERS
5. Align the vent shield with the holes and replace above screws (Figure 5).
6. Secure the vent shield with two fasteners (supplied) to the front upper frame (Figure 6).

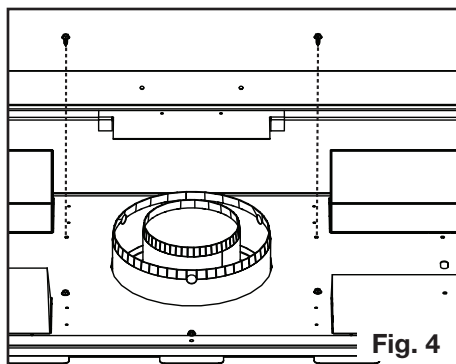

Fig. 4

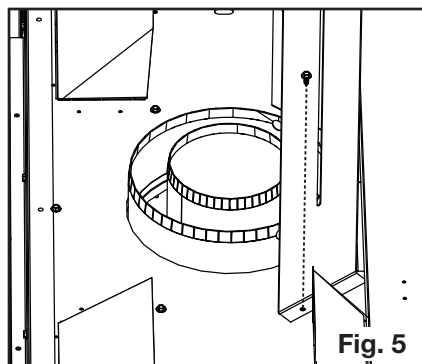

Fig. 5

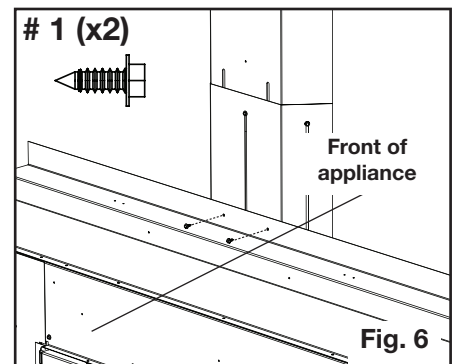
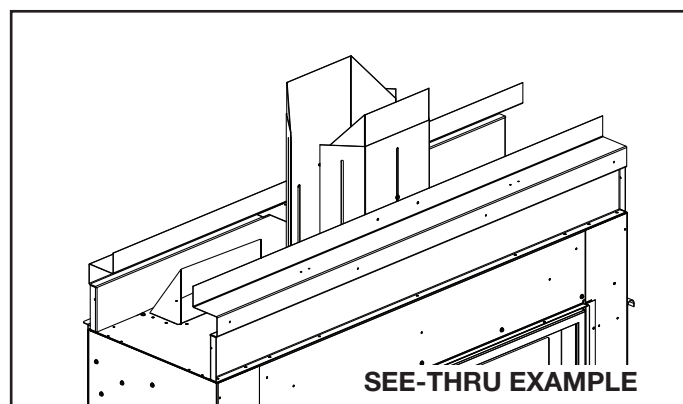

Fig. 6

FOR SEE-THRU APPLIANCES, REPEAT STEPS WITH THE OPPOSITE SIDE (2 vent shields required)



SEE-THRU EXAMPLE

7.1 hard wiring connection

It is necessary to hard wire this appliance.

Permanently framing the appliance with an enclosure, requires the appliance junction box to be hard wired. This appliance must be electrically connected and grounded in accordance with local codes. In the absence of local codes, use the current CSA C22.1 Canadian Electrical Code in Canada or the ANSI/NFPA 70-1996 National Electrical Code in the United States.

7.2 receptacle wiring diagram

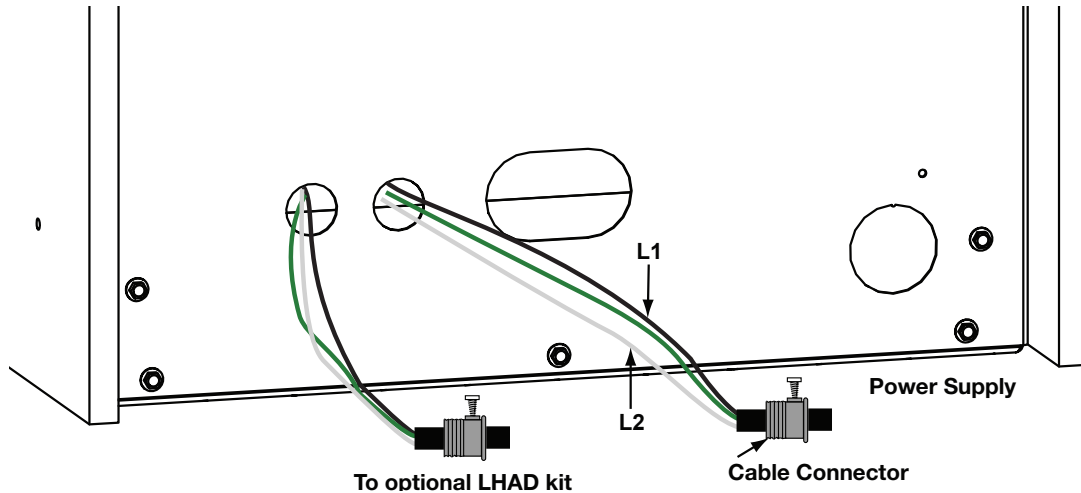

7.3 in the event of a power failure

If the battery holder/switch is equipped with batteries, the appliance will still have ON/OFF functions during a power failure. Refer to “operation” section in the Owner’s manual when communications between battery holder/switch and remote have been lost. The battery holder/switch will emit a “beep” sound to confirm programming has been successful once power is restored. During a power failure, if the fireplace was on, the flame height will stay at the setting prior to the failure. If off when the failure occurs and then turned on, the flame height will come on at “HI”. The flame height can then be controlled by the remote.

In most cases, your appliance will operate with simple functions available until power is restored. All other electrical features / accessories will not work during a power failure.

electrical information

7.4 battery holder/switch installation

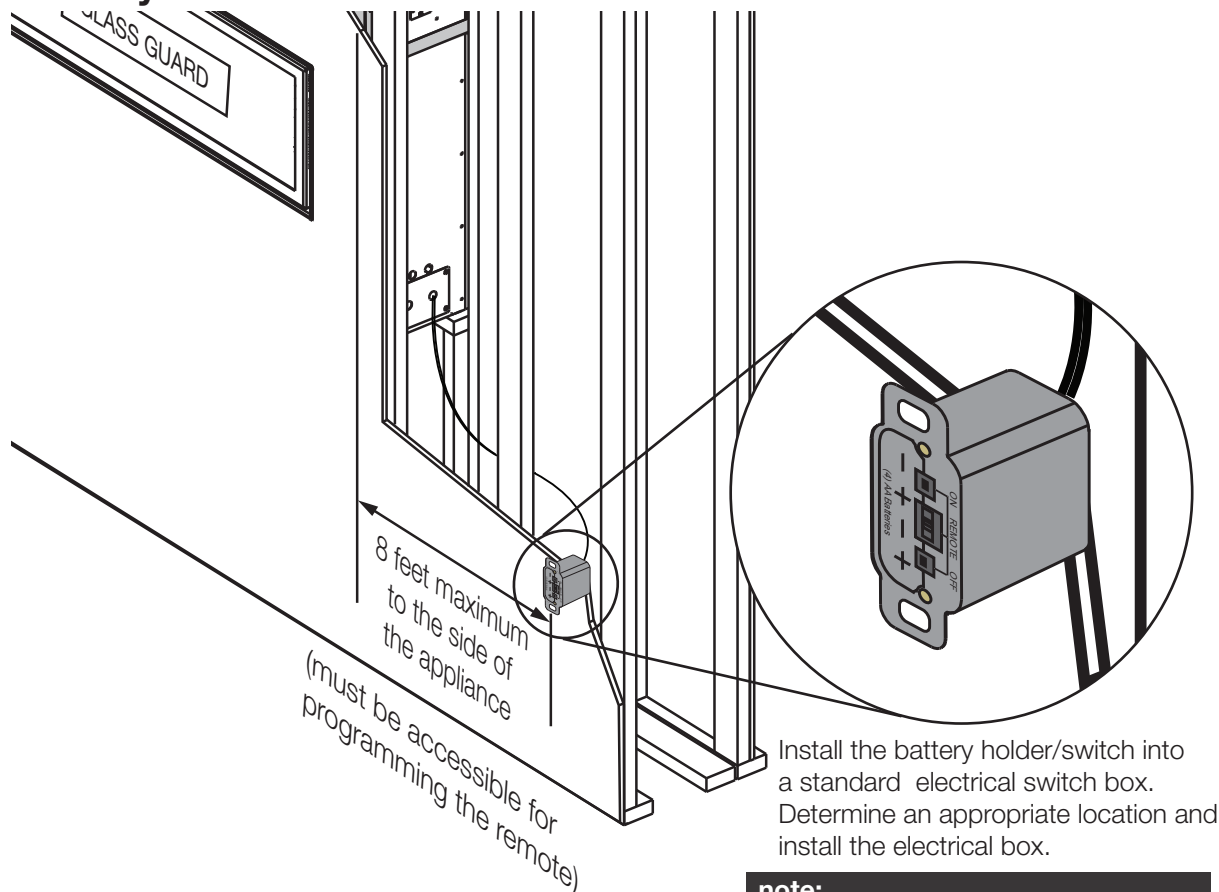

note:

Ensure the 3 position slider switch is in the "REMOTE" position (middle).

7.5 initializing the battery holder/switch for the first time

note:

The initializing process must be completed within 10 seconds of pressing the reset / program (PRG).

- A. Install the 4 AA batteries into the holder, note the polarity of the batteries and insert as indicated on the cover (+/-).
- B. Ensure the 3 position slider switch is switched to the "REMOTE" position (middle position).
- C. Press the reset/programming button, use a small object such as a paper clip in order to reach the button marked PRG, as shown in the illustration below.
- D. The battery holder will beep 3 times to indicate that it's ready to synchronize with the remote.
- E. Install the 3 AAA batteries into the remote, as shown in the photograph below, then press the ON button, The battery holder will beep 4 times to indicate that the remote's command is accepted.

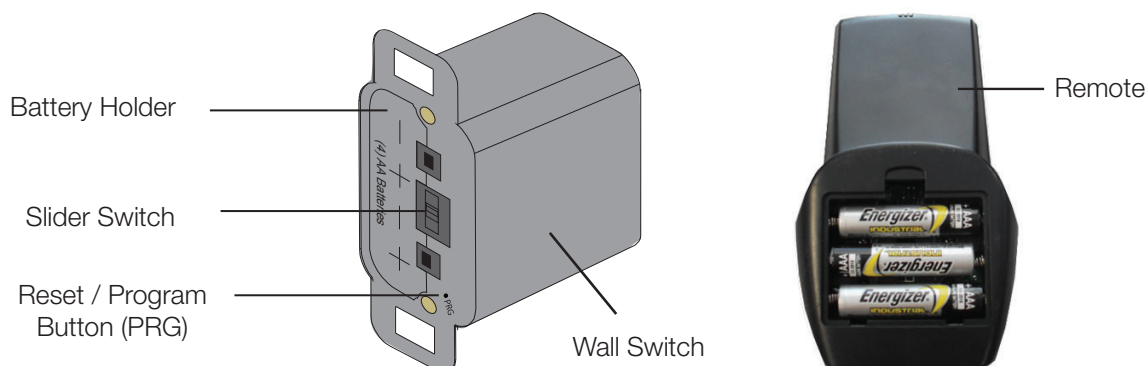

7.6 wiring diagram

WARNING

- Do not wire 110 volts to the valve or wall switch.

note:

This appliance is equipped with a three-prong (grounding) plug for protection against shock hazard and should be connected into a properly grounded circuit. Do not cut or remove the grounding prong from the plug.

7.7 eFire controller application

When fully equipped, the eFIRE application allows you to create every imaginable color, selecting the one that fits your current mood, or your décor with ease, the simple colour wheel tool swiftly scrolls through the full color spectrum. Napoleon's eFIRE app controls every function of your fireplace including; on/off, flame height and a timer to create a schedule for your fireplace that works for you.

Using the instructions on the eFIRE controller application website <http://napoleon.com/efire>, install the app and enjoy the features the eFIRE Controller app offers.

note:

The remote control is considered the master control for the appliance and can always be used to turn the appliance off (for example, in the event the user who's eFIRE controller app was controlling the appliance leaves the home).

electrical information

7.7.1 LVX38-1/ LVX50-1 wiring diagram

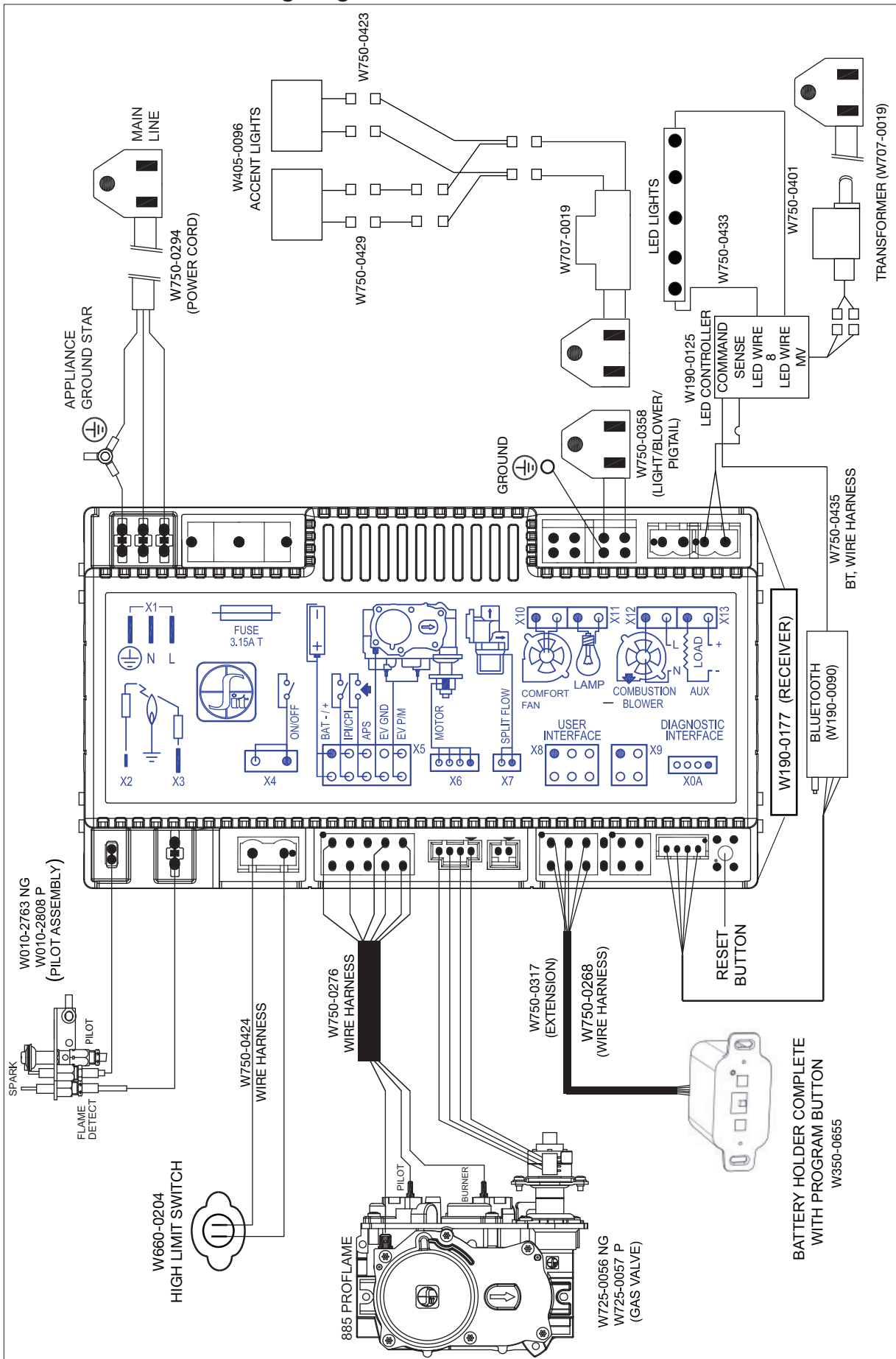

7.7.2 LVX62-1/ LVX74-1 wiring diagram

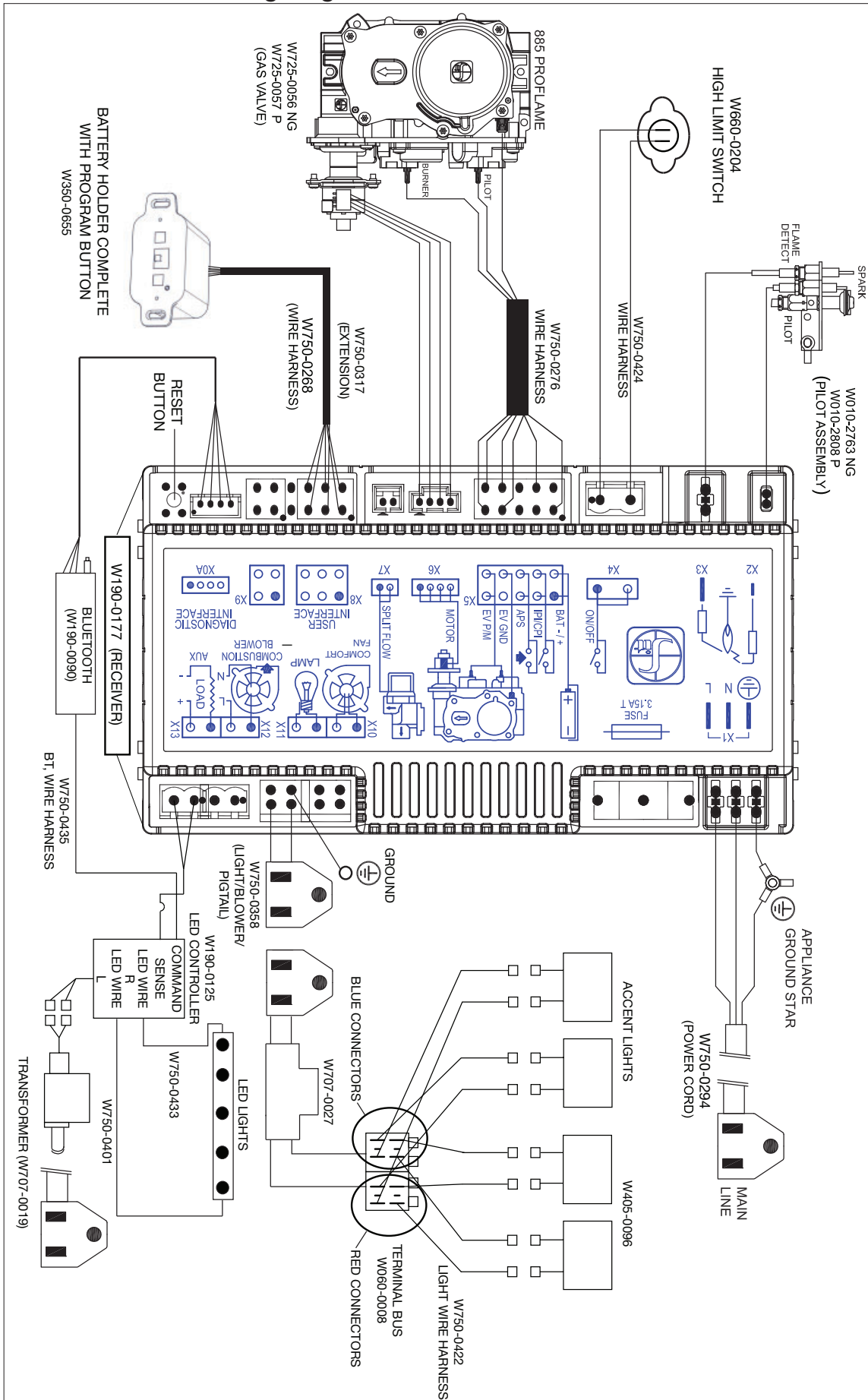

electrical information

7.8 access panel

! WARNING

- Do not use this appliance if any part has been under water. Call a qualified service technician immediately to have the appliance inspected for damage to the electrical circuit.
- Risk of electrical shock or explosion. Do not wire 110V to the valve or to the appliance wall switch. Incorrect wiring will damage controls.
- All wiring should be done by a qualified electrician and shall be in compliance with local codes. In the absence of local codes, use the current CSA22.1 Canadian Electric Code in Canada or the current National Electric Code ANSI/NFPA NO. 70 in the United States.
- Always light the pilot whether for the first time or if the gas supply has run out, with the glass door opened or removed.

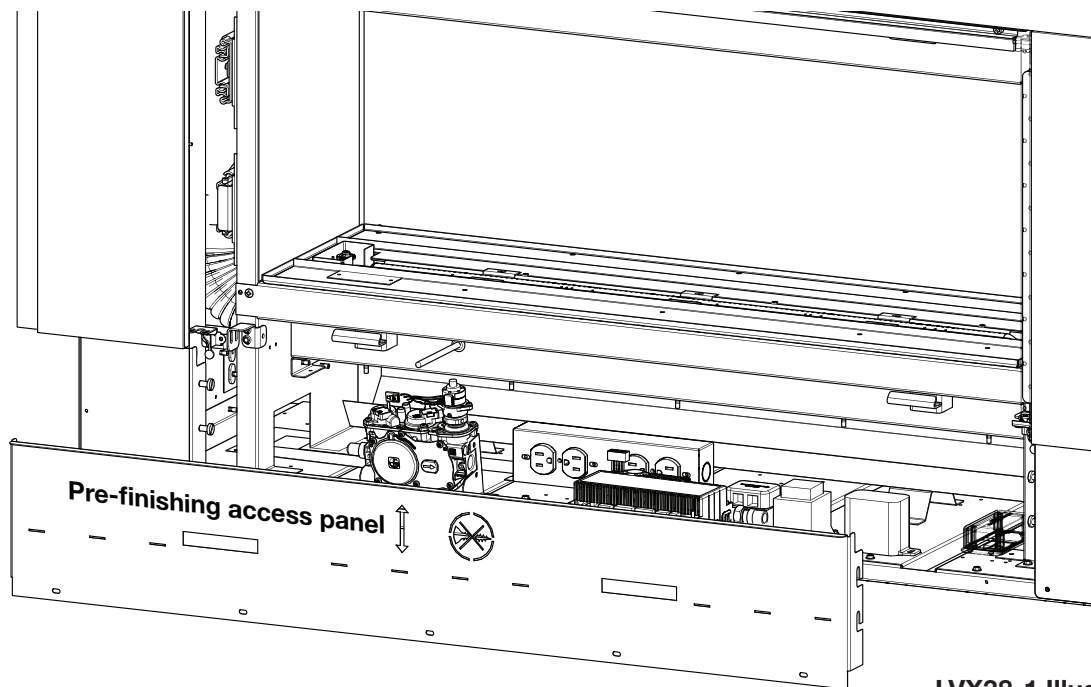

LVX38-1 Illustrated

Before finishing in the appliance, test the operation using the remote control, cycling it through all of its different modes, see “operation” section in the owner’s manual. Once finished in, access to the control components can only be done through the inside of the appliance.

! WARNING

- Risk of fire, explosion, or asphyxiation. Ensure there are no ignition sources such as sparks or open flames.
- Support gas control when attaching gas supply pipe to prevent damaging gas line.
- Always light the pilot whether for the first time or if the gas supply has run out with the glass door opened or removed. Purging of the gas supply line should be performed by a qualified service technician. Ensure that a continuous gas flow is at the burner before closing the door. Ensure adequate ventilation. For gas and electrical locations, see “dimensions” section.
- All gas connections must be contained within the appliance when complete (**gas fireplaces only**).
- High pressure will damage valve. Disconnect gas supply piping before testing gas line at test pressures above 1/2 PSIG.
- Valve settings have been factory set, do not change.

Installation and servicing to be done by a qualified installer.

- Move the appliance into position and secure.
- If equipped with a flex connector, the appliance is designed to accept a 1/2” (13mm) gas supply. Without the connector, it is designed to accept a 3/8” (9.5mm) gas supply. The appliance is equipped with a manual shut off valve to turn off the gas supply to the appliance.
- Connect the gas supply in accordance to local codes. In the absence of local codes, install to the current CAN/CSA-B149.1 Installation Code in Canada or to the current National Fuel Gas Code, ANSI Z223.1 / NFPA 54 in the United States.
- When flexing any gas line, support the gas valve so that the lines are not bent or kinked.
- The gas line flex-connector should be installed to provide sufficient movement for shifting the burner assembly on its side to aid with servicing components.
- Check for gas leaks by brushing on a soap and water solution. **Do not use open flame.**

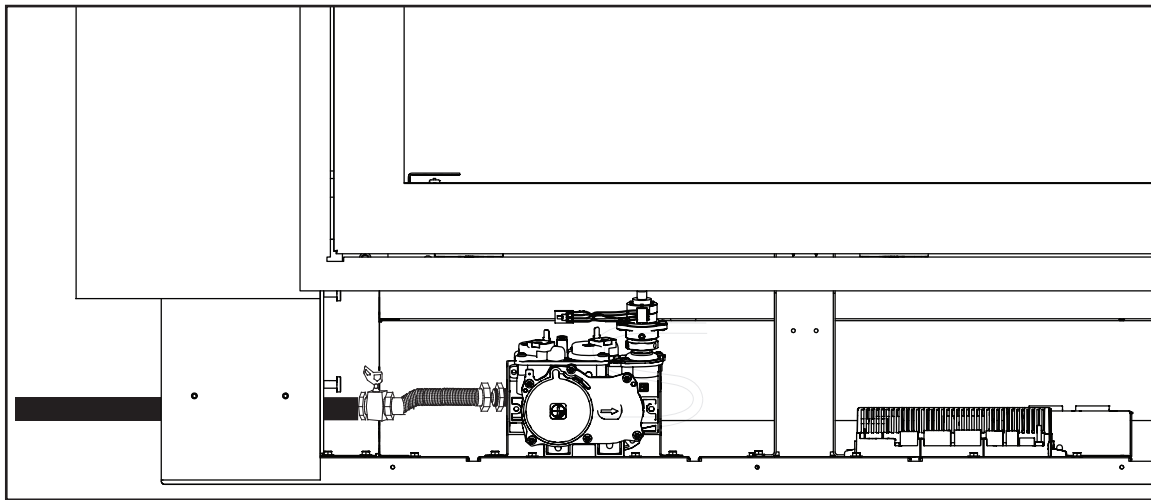
**note:**

Connect the gas supply to the 1/2” (13mm) shut off and flex connector (supplied). Ensure gas supply is secured.

After installing the electrical wiring and gas lines, ensure to test the appliance before finishing the framing and finishing the appliance.

Before finishing in the appliance test the operation using the remote control, cycling it through all of its different modes, see “operation” section in the Owner’s manual. Should troubleshooting be required, access to the controls can be made through the pre-finishing access panel. All other functions, excluding the burner operation, will not operate during the event of a power failure.

9.0 operation

WARNING

- If you do not follow these instructions exactly, a fire or explosion may result causing property damage, personal injury, or loss of life.
- If applicable, always light the pilot whether for the first time or if the gas supply has run out with the glass door opened or removed.

Ensure that a continuous gas flow is at the burner before installing the door. When lit for the first time, the appliance will emit an odor for a few hours. This is a normal temporary condition caused by the “burn-in” of paints and lubricants used in the manufacturing process and will not occur again. After extended periods of non-operation, such as, following a vacation or warm weather season, the appliance may emit a slight odor for a few hours. This is caused by dust particules in the heat exchanger burning off. In both cases, open a window to sufficiently ventilate the room.

FOR YOUR SAFETY READ BEFORE LIGHTING

- Do not turn on if children or other at risk individuals are near the appliance.
- This appliance is equipped with an ignition device which automatically lights the pilot. Do not try to light the pilot by hand.
- Before operating, smell all around the appliance area for gas and next to the floor because some gas is heavier than air and will settle on the floor.
- Do not use this appliance if any part has been under water. Immediately call a qualified service technician to inspect the appliance and replace any part of the control system and any gas control which has been underwater.

WHAT TO DO IF YOU SMELL GAS

- Turn off all gas to the appliance.
- Open windows.
- Do not try to light any appliance.
- Do not touch any electric switch; do not use any phone in your building
- Immediately call your gas supplier from a neighbour's phone. Follow the gas supplier's instructions.
- If you cannot reach your gas supplier, call the fire department.

LIGHTING INSTRUCTIONS

note:

This appliance is equipped with an ignition device which automatically lights the pilot. Do not try to light the pilot by hand.

- Stop! Read the above safety information on this label.
- Remove batteries from the transmitter and set thermostat to lowest setting, if equipped.
- Turn off all electrical power to the appliance.
- Open the glass door, if equipped.
- Turn the manual shut-off valve clockwise to the “OFF” position. (Shut-off valve is located on the flex connector).
- Wait five (5) minutes to clear out any gas. If you smell gas including near the floor, **STOP!** Follow the instructions above in the “WHAT TO DO IF YOU SMELL GAS” section. If you don't smell gas; close the glass door and go to the next step.
- Turn the manual shut-off valve counter clockwise to the “ON” position.
- Turn on all electrical power to the appliance and re-install the batteries into the transmitter. Set thermostat to desired setting, if equipped.
- Turn on the remote wall switch to the appliance.
- If the appliance will not operate, follow instructions “TO TURN OFF GAS” and call your service technician or gas supplier.

TO TURN OFF GAS

- Set thermostat to lowest setting, if equipped.
- Turn off the remote wall switch to the appliance.
- Turn off all electric power to the appliance if service is to be performed.
- Turn manual shutoff valve clockwise to the “OFF” positon. Do not force.

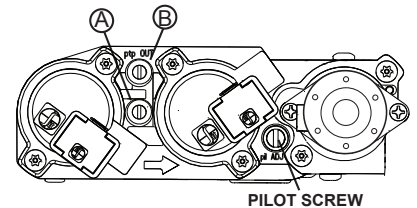
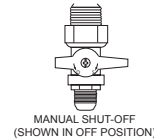

9.1 pilot-on-demand

This appliance is equipped with an “On Demand” intermittent pilot ignition system (IPI) which also includes a continuous pilot ignition (CPI) mode with an integrated seven day timer. This system minimizes your appliance’s carbon footprint as well as reducing its annual fuel consumption and operating costs.

In IPI mode, the pilot will ignite prior to the main burner, when the appliance is turned on using a switch, remote or from a call for heat with the thermostat (if equipped). Once the appliance is turned off (or the call for heat is satisfied), the main burner and pilot flame will shut down.

The continuous (CPI) mode is intended to enhance the performance of the appliance during the startup phase in colder climates and extreme weather by keeping the system warm when the main burner is not in use. However, the timer feature provides the convenience that the appliance automatically switches off the pilot when the appliance has not been used for seven days to save unnecessary fuel consumption.

When the CPI function is turned on, the pilot will remain on after the main burner is turned off. A timer will then begin the countdown for approximately seven days before shutting off the pilot if the appliance is not used. This countdown will reset anytime the appliance main burner is used. Therefore, if the appliance is regularly used day to day, the pilot will remain on. However, this system does not require the user to remember to turn the pilot off as summer approaches and avoids unnecessary fuel consumption while still readily turned back on when the cold weather returns.

Your appliance may be equipped with an ACS or remote control device which enables you to select IPI or CPI modes.

If your appliance is equipped with an ACS switch, it has the option to change modes. If installed with the blue wire facing up, flipping the switch UP turns on the continuous pilot with timer and flipping the switch DOWN turns on the intermittent pilot ignition. If installed with the white wire facing up, the opposite is true.

If your appliance is equipped with a remote control device capable of selecting IPI / CPI modes, refer to remote operating instructions.

In order to start your pilot, turning the main burner on with the switch, remote or thermostat and then turning it off will reactivate the continuous pilot mode and reset the seven day timer.

For further information, refer to www.napoleon.com/pilotondemand.



10.0 nailing tab installation

important:

If the front frame was removed, it **must** be reinstalled prior to installing the nailing tabs.

1

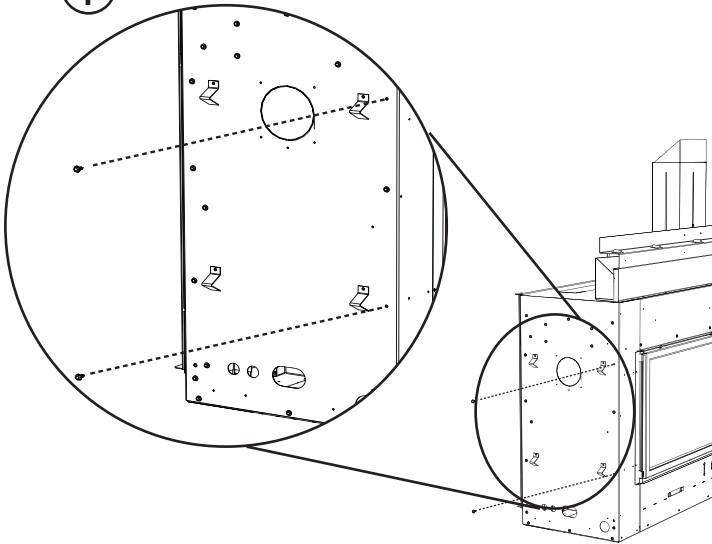

REMOVE THE SCREWS FROM THE APPLIANCE.
DO NOT DISCARD.

2

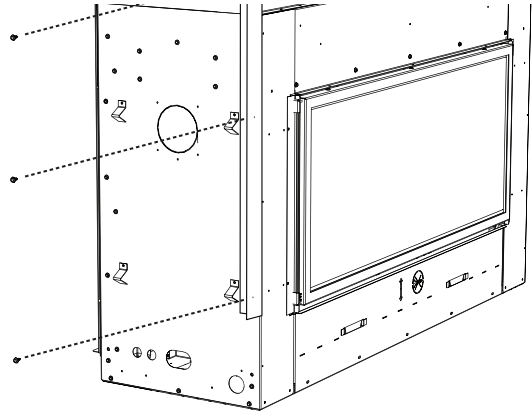

ALIGN THE NAILING TAB WITH THE HOLES ON THE APPLIANCE,
SECURE WITH THE SCREWS FROM STEP 1.

3

1 (x2)

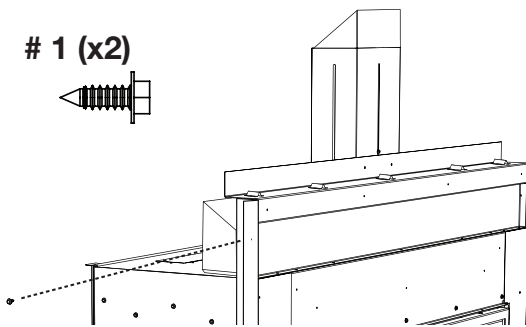

SECURE WITH SCREW SUPPLIED IN THE MANUAL BAGGIE TO
THE UPPER FRONT FRAME

TO INSTALL NAILING TABS FOR SEE-THRU APPLIANCES, REPEAT STEPS WITH THE OPPOSITE SIDE.

note:

See "venting", "electrical information" and "gas installation" sections prior to finish framing.

11.0 finish framing - after appliance installation

11.1 framing with Dynamic Heat Control™

note:

Appliances can be built in with combustible framing and finishing unless stated.

There are various methods to ventilate the enclosure. Refer to “Dynamic Heat Control™” and “installation planning” sections.

The appliance must be installed at this point of framing. Appliance is not shown to better illustrate finish framing.

single-sided flush

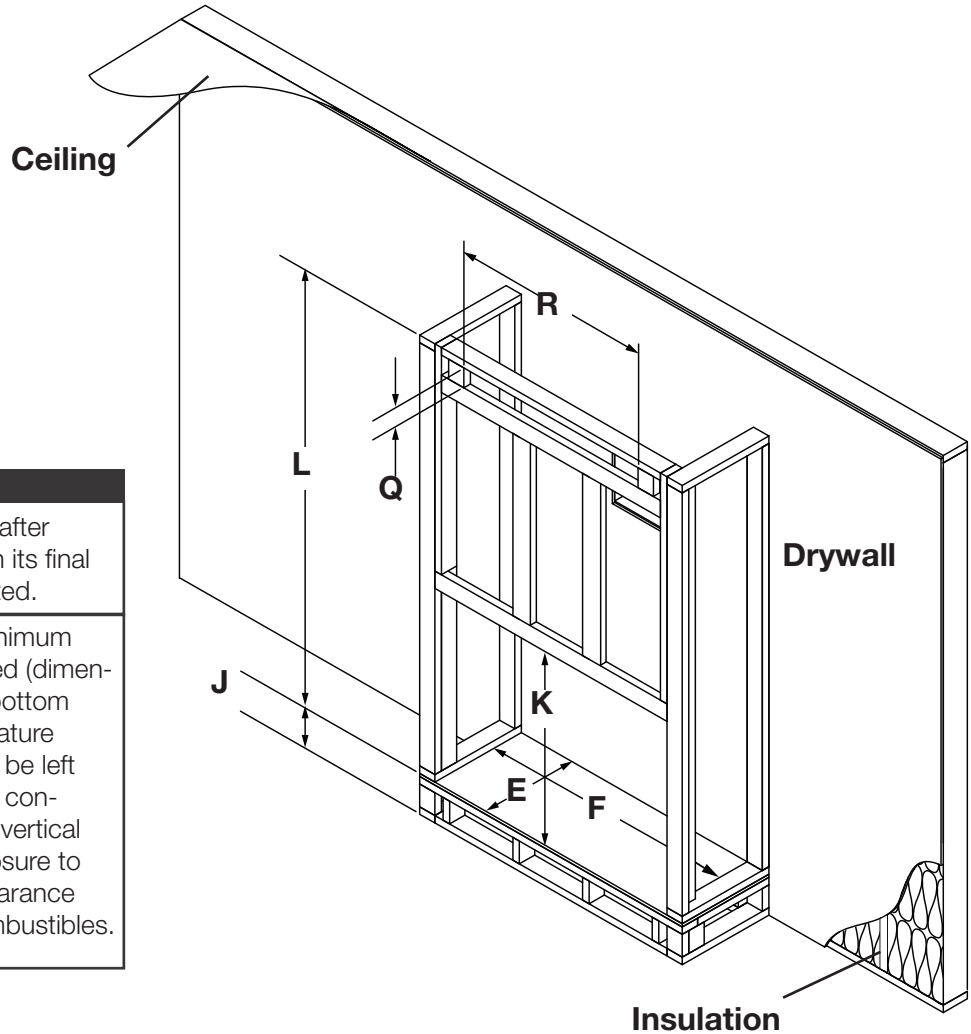

note:

Finish framing **must** be built after appliance has been placed in its final position and venting connected.

The LVX series requires a minimum enclosure height, as illustrated (dimension L), measured from the bottom of the appliance. For temperature requirements, this area must be left unobstructed. Some venting configurations that require more vertical rise will require a larger enclosure to provide minimum vertical clearance between vent pipes and combustibles.

Option 2 illustrated (appliance not shown)

minimum framing

Ref	LVX38-1	LVX50-1	LVX62-1	LVX74-1
K	39 15/16" (101.4cm)			
E**	18" (45.7cm)			
F	53 13/16" (136.7cm)	65 13/16" (167.2cm)	77 13/16" (197.6cm)	89 13/16" (228.1cm)
J	Optional - Appliance does not need to be elevated above floor			
L	73" (185.4cm)		91" (231.1cm)	
Q*	2" min and 3" max			
(Q x R)*	80 sq. in.		160 sq. in.	

* ONLY APPLICABLE TO OPTION 2 AND 3 - Opening **must** be centered in enclosure on appliance. Dimensions represent finished sizes and where applicable should be adjusted to include finish material thickness.

**Max. 21" (53.5cm).

finish framing - after appliance installation

single-sided recessed

! WARNING

- Shaded components (finish framing) **must** be non-combustible materials.

note:
 Finish framing **must** be built after appliance has been placed in its final position and venting connected.

This configuration also requires recess area to use non-combustible facing due to close proximity to vent.

The LVX series requires a minimum enclosure height, as illustrated (dimension L), measured from the bottom of the appliance. For temperature requirements, this area must be left unobstructed. Some venting configurations that require more vertical rise will require a larger enclosure to provide minimum vertical clearance between vent pipes and combustibles.

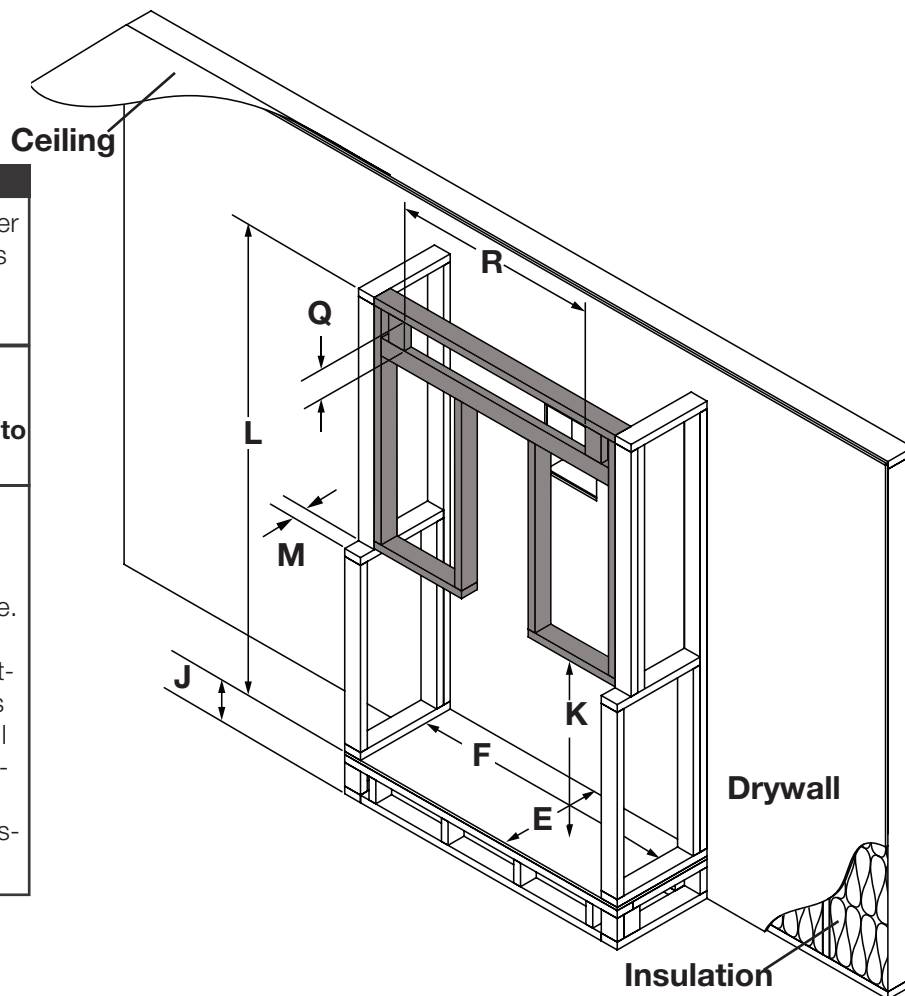

Option 2 illustrated (appliance not shown)

minimum framing

Ref	LVX38-1	LVX50-1	LVX62-1	LVX74-1
K	39 15/16" (101.4cm)			
E***	18" (45.7cm)			
F	53 13/16" (136.7cm)	65 13/16" (167.2cm)	77 13/16" (197.6cm)	89 13/16" (228.1cm)
J	Optional - Appliance does not need to be elevated above floor			
L	73" (185.4cm)		91" (231.1cm)	
Q*	2" min and 3" max			
(Q x R)*	80 sq. in.		160 sq. in.	
M**	3" (76mm)			

* ONLY APPLICABLE TO OPTION 2 AND 3 - Opening **must** be centered in enclosure on appliance. Dimensions represent finished sizes and where applicable should be adjusted to include finish material thickness.

** Can only be increased to 4" max by building a protrusion.

***Max. 21" (53.5cm).

see-thru flush

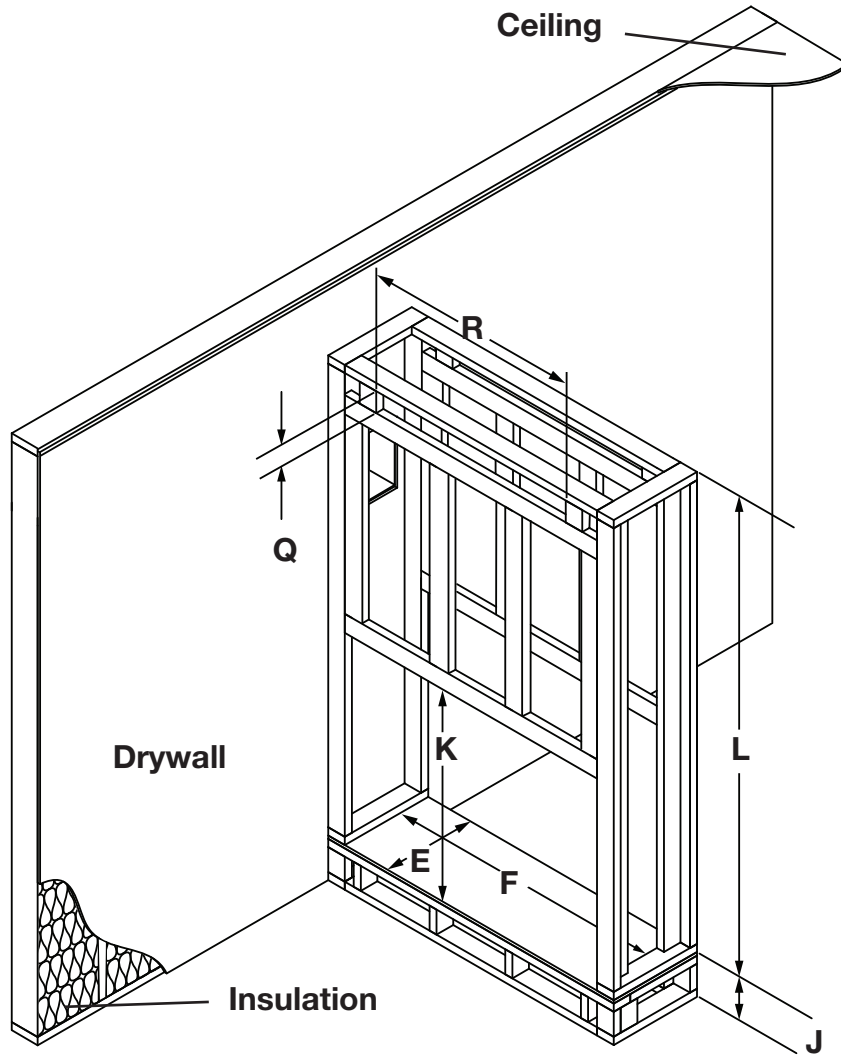

note:

Finish framing **must** be built after appliance has been placed in its final position and venting connected.

The LVX series requires a minimum enclosure height, as illustrated (dimension L), measured from the bottom of the appliance. For temperature requirements, this area must be left unobstructed. Some venting configurations that require more vertical rise will require a larger enclosure to provide minimum vertical clearance between vent pipes and combustibles.

Option 2 illustrated (appliance not shown)

minimum framing

Ref	LVX38-1	LVX50-1	LVX62-1	LVX74-1
K	39 15/16" (101.4cm)			
E**	16 3/16" (41.1cm)			
F	53 13/16" (136.7cm)	65 13/16" (167.2cm)	77 13/16" (197.6cm)	89 13/16" (228.1cm)
J	Optional - Appliance does not need to be elevated above floor			
L	73" (185.4cm)		91" (231.1cm)	
Q*	2" min and 3" max			
(Q x R)*	80 sq. in.		160 sq. in.	

* ONLY APPLICABLE TO OPTION 2 AND 3 - Opening **must** be centered in enclosure on appliance. Dimensions represent finished sizes and where applicable should be adjusted to include finish material thickness.

**Max. 21" (53.5cm).

finish framing - after appliance installation

see-thru built out

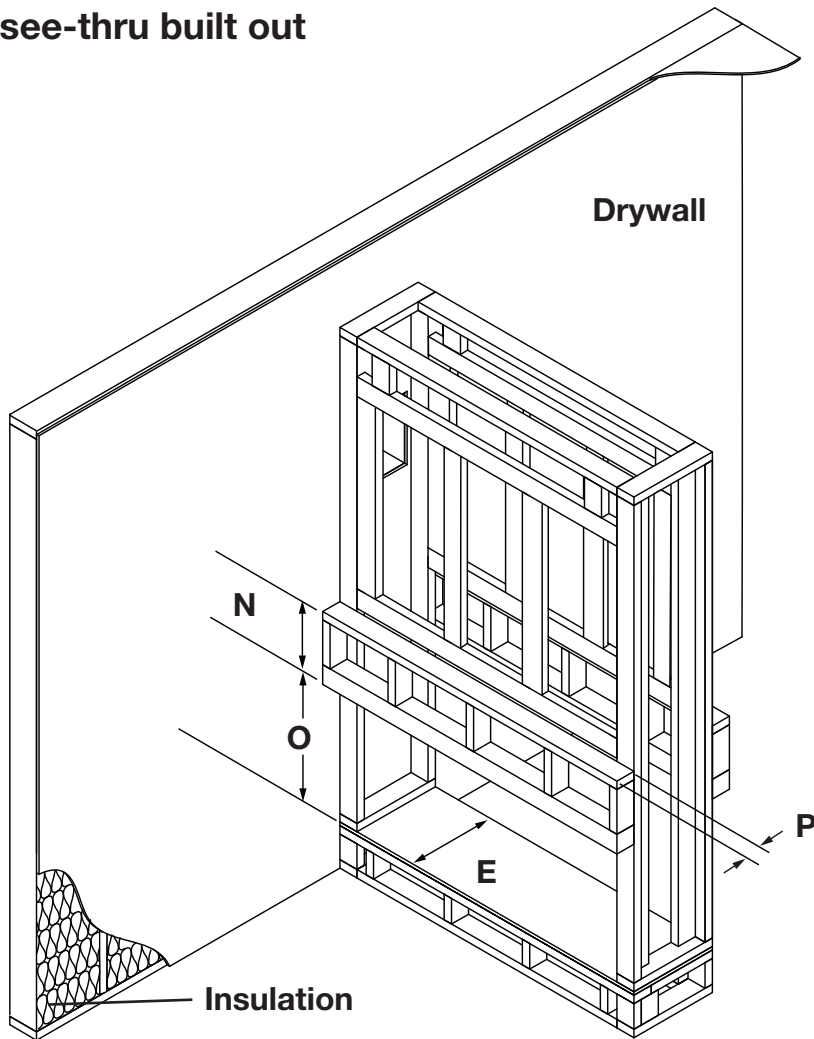

note:
Finish framing **must** be built after appliance has been placed in its final position and venting connected.

Option 2 illustrated (appliance not shown)

minimum framing

Ref	LVX38-1	LVX50-1	LVX62-1	LVX74-1
E***		16 3/16" (41.1cm)		
N* / **		14 1/4" (36.2cm)		
O*		25 11/16 (65.2cm)		
P*		4" (10.1cm) Max		

* Thickness of finishing material **must** be considered when constructing the framing for the protrusion (i.e. Dimensions such as N, O, & P includes framing and finish material). If desired, side and bottom protrusions are also permitted with 4" (10.1cm) Max. (finishing material not illustrated)

** This is a recommended dimension when mounting electronics above the appliance. Otherwise, it can be as minimal as construction permits.

***Max. 21" (53.5cm).

note:
When finished, **protrusions must never encroach inside the appliance finishing flange** as this will impede the fitment of the barrier and safe operation. See "finishing" section in the installation manual.

note:
The LVX series requires a minimum enclosure height, as illustrated (dimension L), measured from the bottom of the appliance. For temperature requirements, this area must be left unobstructed. Some venting configurations that require more vertical rise will require a larger enclosure to provide minimum vertical clearance between vent pipes and combustibles.

wiring locations

TV applications were tested with the minimum enclosure dimensions and the maximum recess permissible. This data is provided in good faith and is not a guarantee for every application and television. Care and consideration should be taken when planning these installations to ensure the temperatures around the TV meet all manufacturer's recommended operating temperatures. Increasing the height of the mantel and/or TV above the fireplace opening, the protrusion of mantel and the volume of the enclosure all have the effect of reducing the temperature above the fireplace.

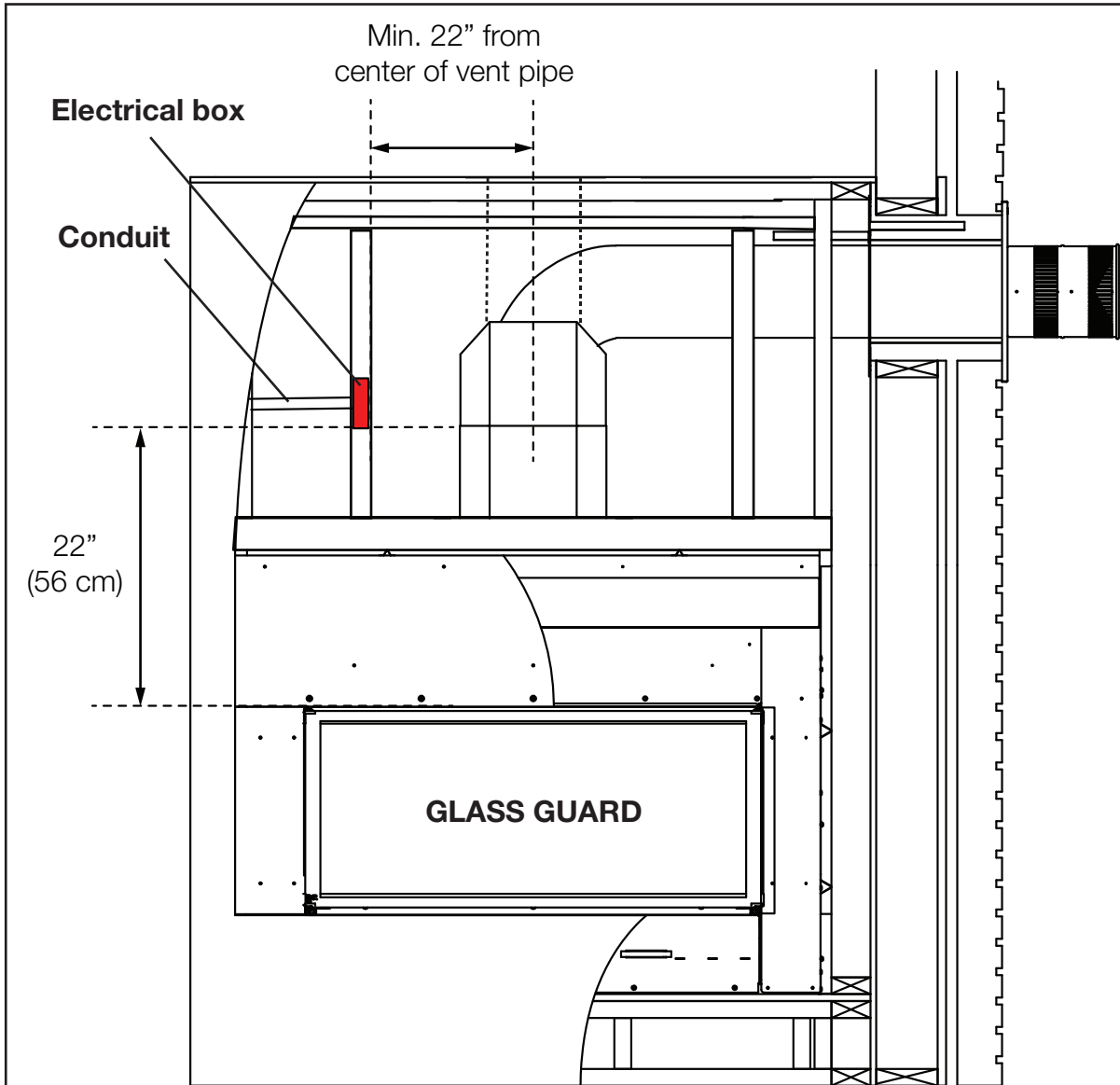

12.0 finishing

! WARNING

- Risk of fire!
- Never obstruct the front opening of the appliance.
- The front of the appliance must be finished with any non-combustible materials such as brick, marble, granite, etc., provided that these materials do not go below the specified dimension, as illustrated.
- Do not strike, slam, or scratch. Do not operate appliance with glass removed, cracked, or scratched.
- Facing and/or finishing material must never overhang into the appliance opening.
- The glass door assembly is a safety device designed to pivot forward when relieving excess pressure that might occur. Finishing or other materials must not be located in the opening surrounding the door as this will interfere with the doors ability to relieve pressure.

12.1 fastener placement restriction

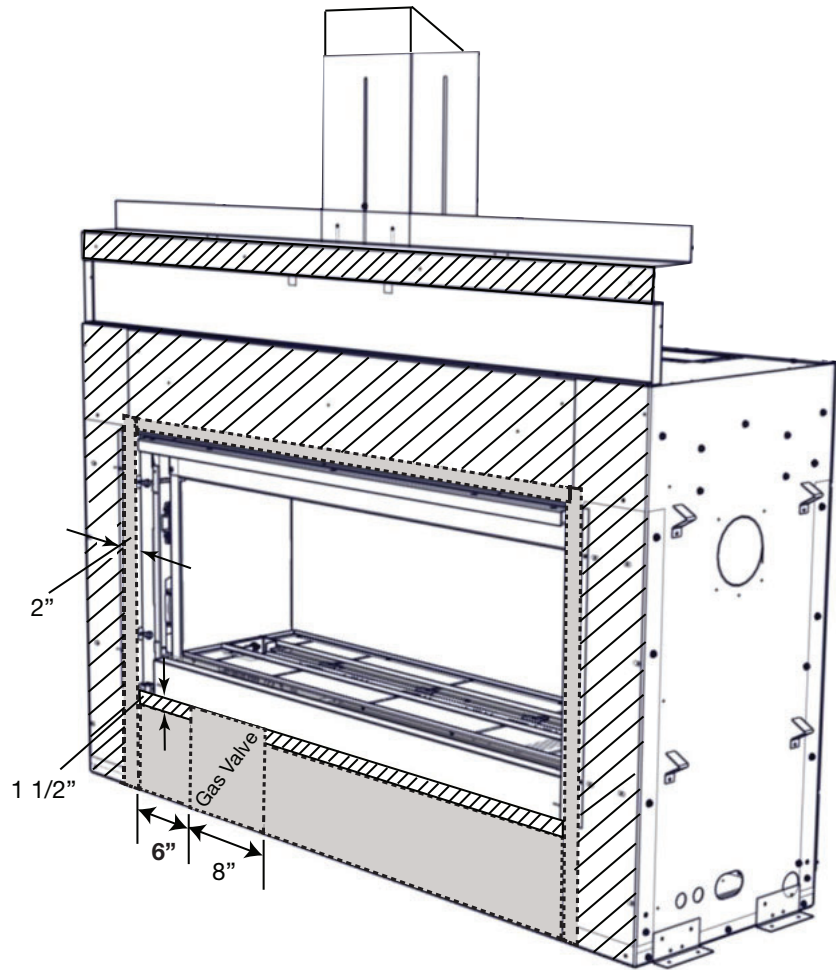

No fasteners permitted.



No fasteners permitted with greater than 3/4" penetration into appliance.

When securing non-combustibles, we suggest using high temperature construction adhesive within 2" (5.08cm) above and to the sides from the appliance opening and 8" (20.3cm) below the appliance opening. **DO NOT SCREW IN THE RESTRICTED AREA AS THIS COULD DAMAGE THE INTERNAL COMPONENTS OF THE APPLIANCE THAT CAN CAUSE INJURY OR DEATH.**

This applies to both single-sided and see-thru appliances.

Maximum screw length to be used outside the restricted screw area is 3/4" greater than finishing material thickness.(i.e. no fastener permitted that penetrates the appliance more than 3/4"

12.2 enclosure design

Additional openings in the closure are not acceptable since the DHC™ system relies on the “chimney effect” created through the appliance and the enclosure.

By adding additional air inlet(s) to an enclosure, air can bypass the appliance, which increases the operating temperature of the appliance and around the appliance opening. This is counterproductive when trying to demonstrate the benefits of heat management to potential customers. In extreme cases, the appliance may become hot enough for the high limit switch to shut down the appliance.

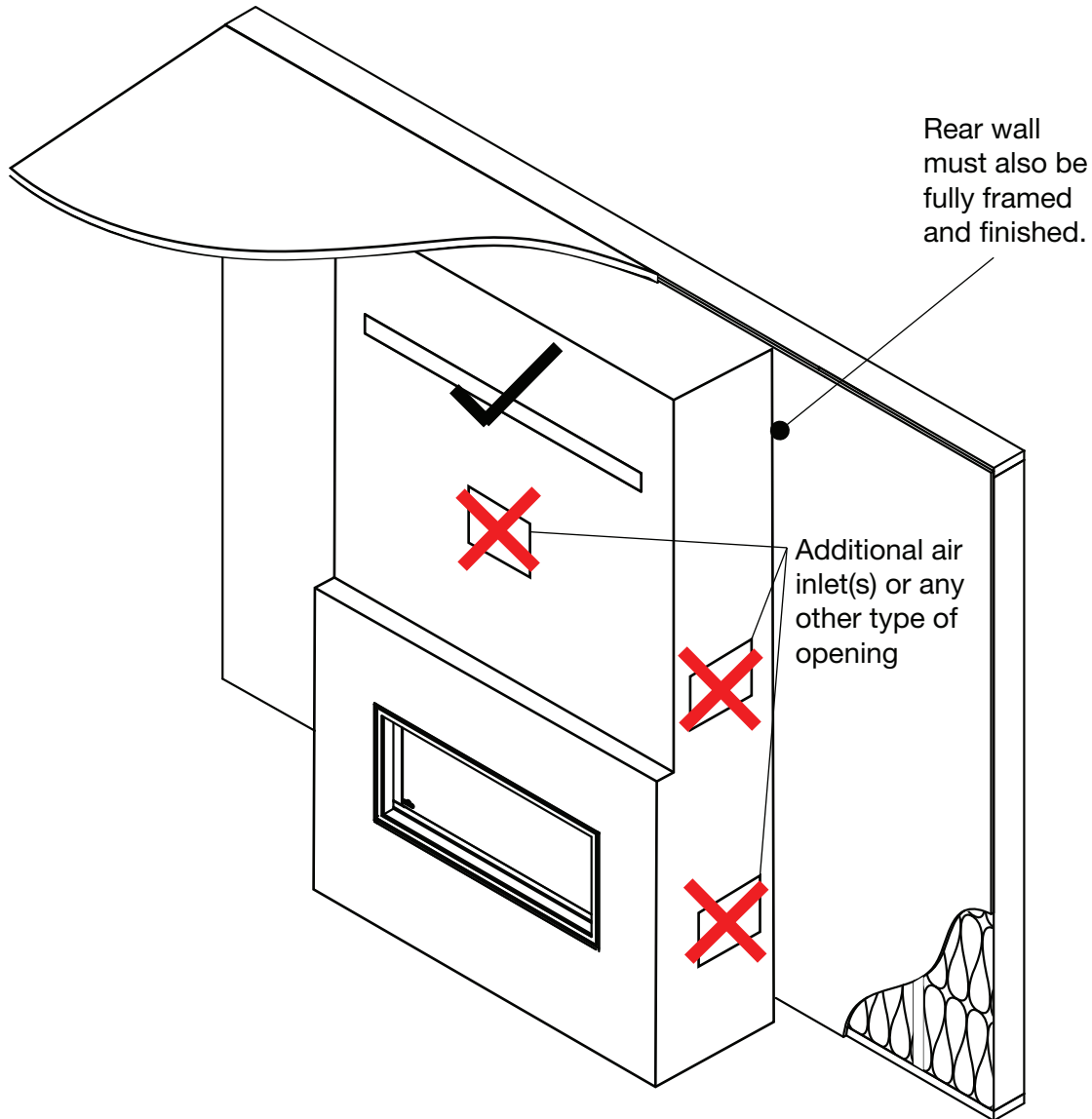
**note:**

The outside of the enclosure must be finished on all four sides and must include a complete floor.

finishing

12.3 finishing with combustibles

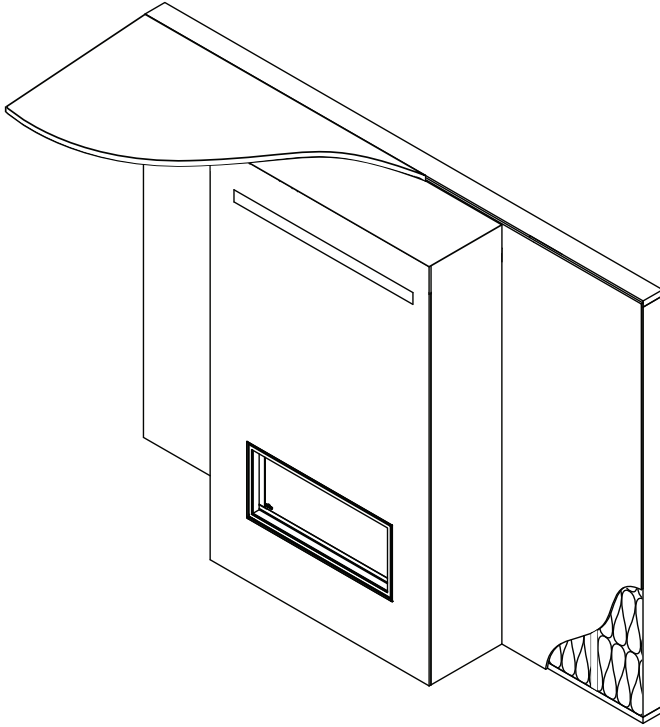

With Dynamic Heat Control™, you can finish the appliance with any combustible materials except appliances with recessed installation. Air outlet opening must be located out of reach of the user. Air outlet opening **must** not be restricted by furnishings or decor.

Recessed installation with Dynamic Heat Control™

! WARNING

- Shaded area must be non-combustible materials.

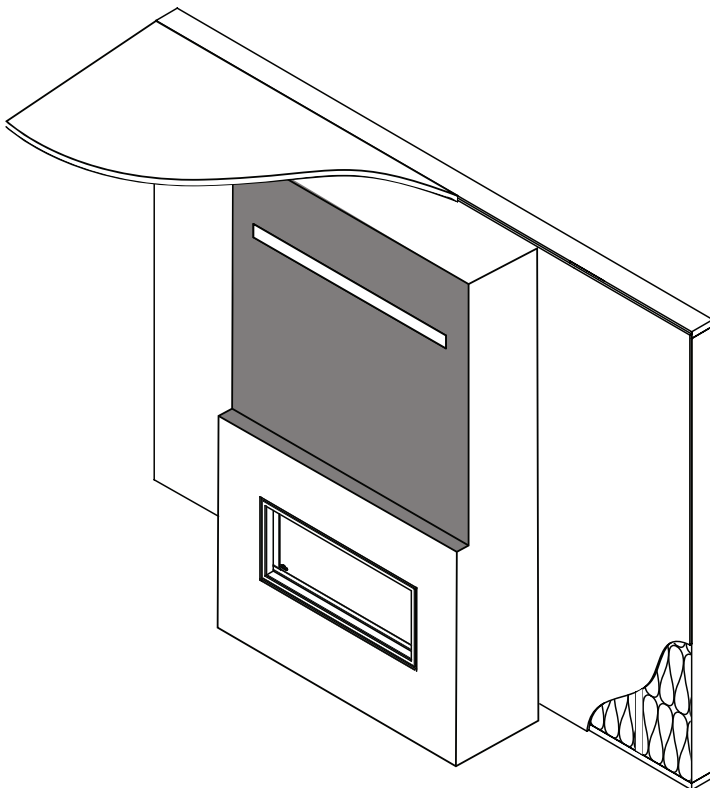

SHADED AREA MUST BE NON-COMBUSTIBLE MATERIALS. Recessed installation **requires** recess material to use non-combustible facing due to close proximity to vent. Air outlet opening must be located out of reach of the user. Air outlet opening **must** not be restricted by furnishings or decor.

! WARNING

- Finishing material tight to the frame around the glass guard assembly frame must not project more than 4" (10cm) from the face of the glass guard (above the door and sides only).

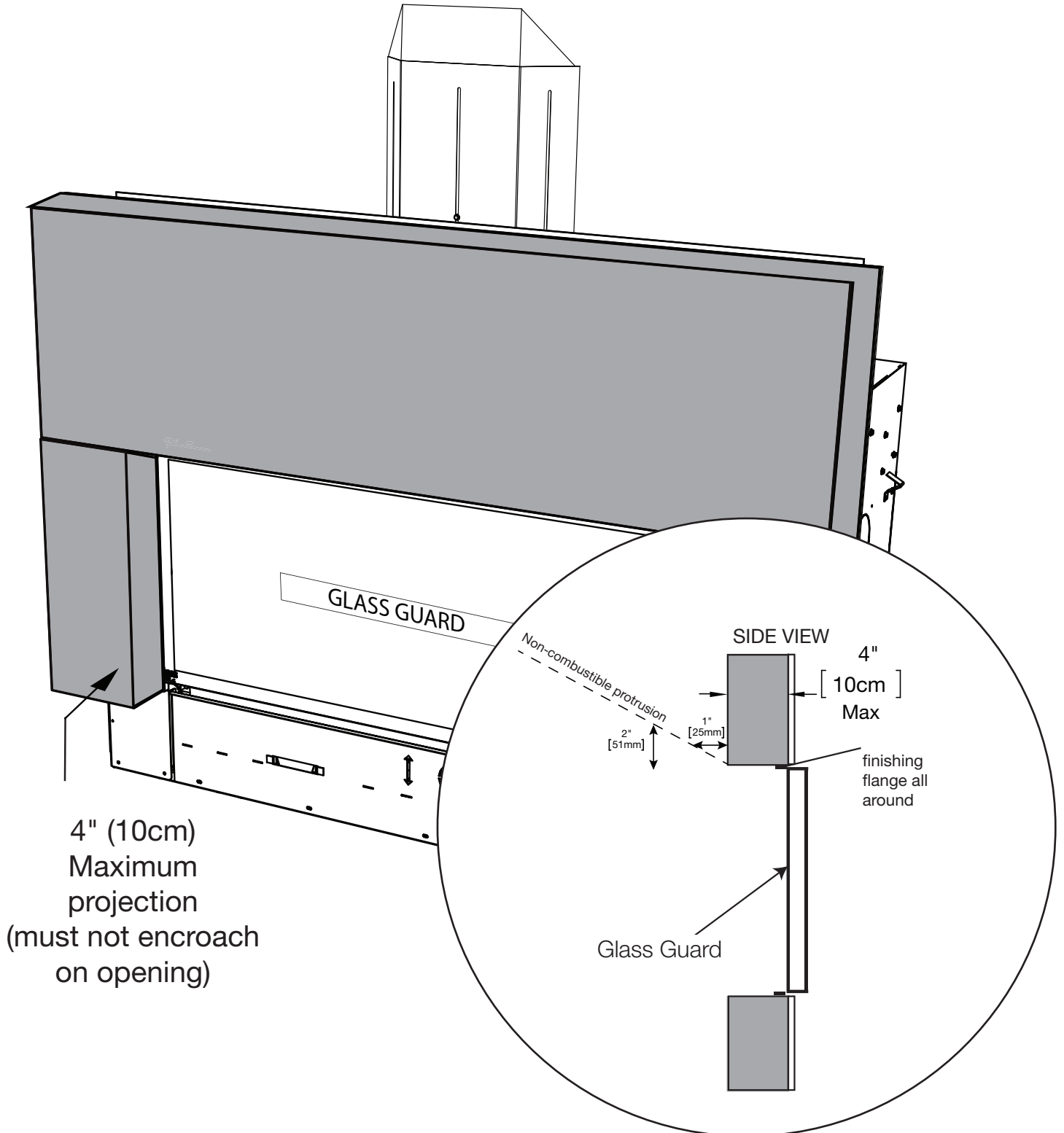

finishing

12.4 minimum combustible mantel clearances

! WARNING

- Risk of fire. Maintain all specified air space clearances to combustibles. Failure to comply with these instructions may cause a fire or cause the appliance to overheat. Ensure all clearances (i.e. back, side, top, vent, mantel, front, etc.) are clearly maintained.
- When using paint or lacquer to finish the mantel, the paint or lacquer must be heat resistant to prevent discolouration.
- Installing a television or other electronics above the appliance may cause discolouration, melting, or damage to the electronics. Use clearances as guidelines and refer to your TV manufacturer's instructions for further information.

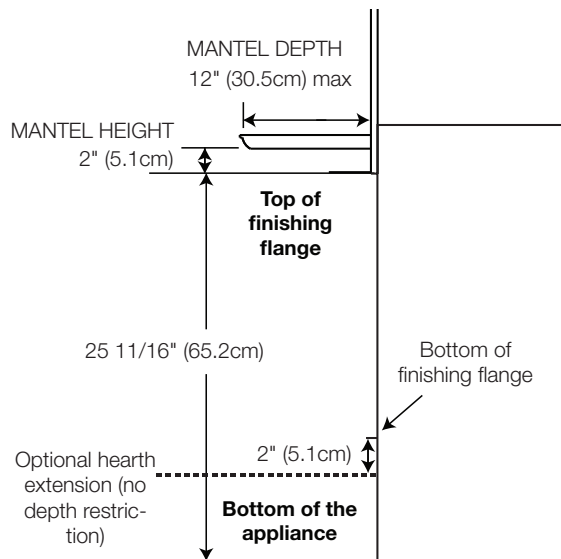

Installing a mantel between this appliance and electronics or other materials that may be sensitive to heat, will reduce the effect of direct heat on them. Follow mantel height and depth instructions for proper clearance information.

A non-combustible mantel is considered a non-combustible protrusion, see "finishing" for protrusion restrictions.

Electronics, picture frames, decors, or other wall-mounted objects must be 6" below the air outlet opening and 6" above the finishing flange.

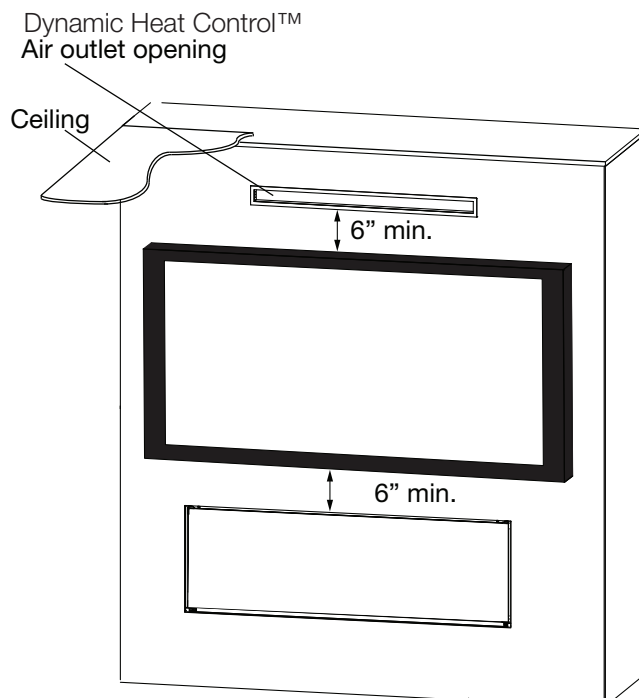

12.5 optional trim finishing

When the appliance is installed with the front (or rear) air outlet opening, a decorative trim kit is available to finish your installation. The trim kit can be painted as an accent colour or to blend in with room decor.

The minimum air opening area must be maintained after the finishing material has been installed.

Contact your local authorized dealer for more information.

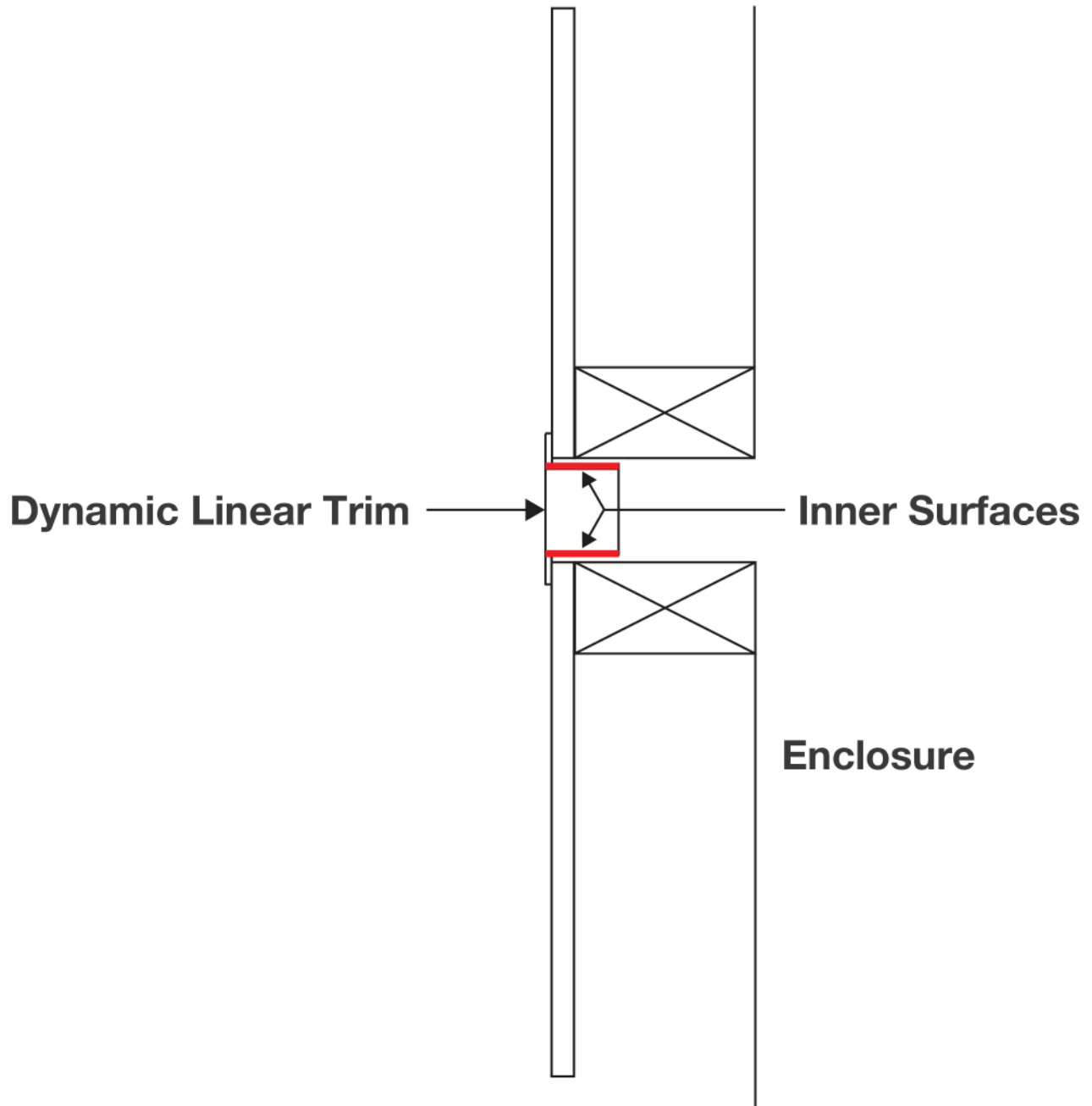

note:

The inner surfaces may be visible.

12.6 glass guard installation / removal

! WARNING

- The polystyrene / styrofoam packaging materials may scratch the glass if the GGA-1 is not covered by the plastic layer.
- Adequate steps must be taken to protect the appliance and Dynamic Heat Control™ (DHC) openings from dirt, debris and damage during finishing.
- The GGA-1 installation and/or removal will require 2 people.
- The GGA-1 should be preliminarily fitted and adjusted before finish framing and finishing the appliance. It is much easier to make adjustments with the appliance pre-finishing access panel removed. It is recommended that the GGA-1 is removed after preliminary adjustment and stored safely in the original packaging whilst finishing is complete. Take precautions to protect the appliance during finishing.

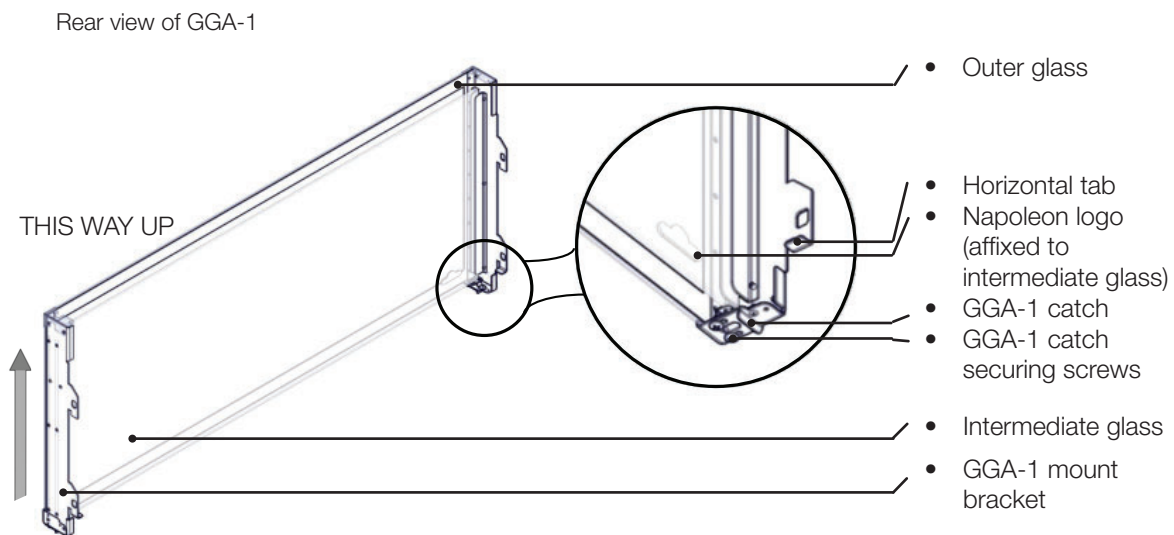
Key Components**Fig. 1**

Access side view of appliance

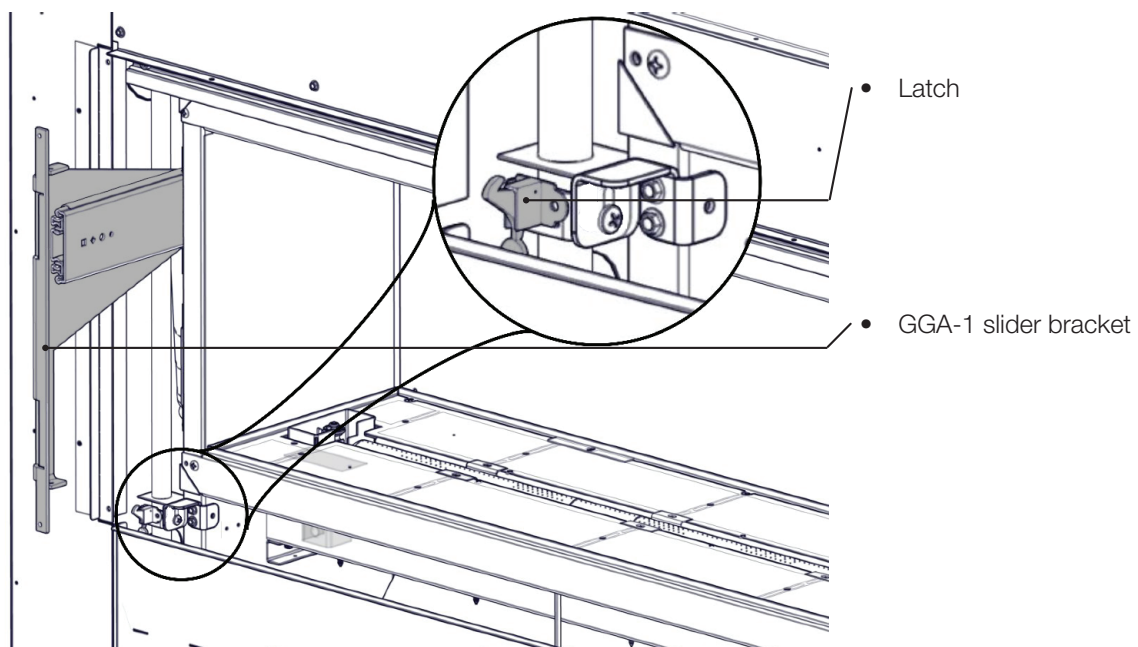
**Fig. 2**

1. Unpack the GGA-1 and keep packaging materials to store the GGA-1 after test fitting.
2. Ensure to handle the GGA-1 as shown **(Fig. 1)** as the floating intermediate glass might fall out of the assembly if handled incorrectly.
3. For ease of installation during preliminary adjustment, remove the door trim, control cover and access panel **(Fig. 3)**.

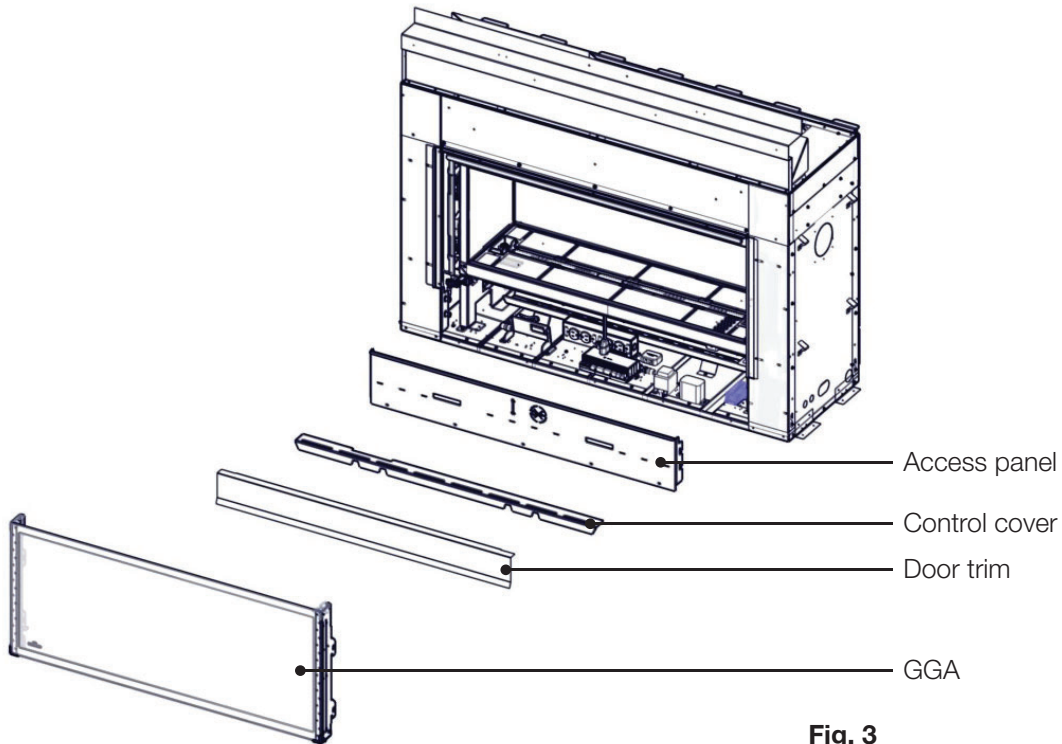
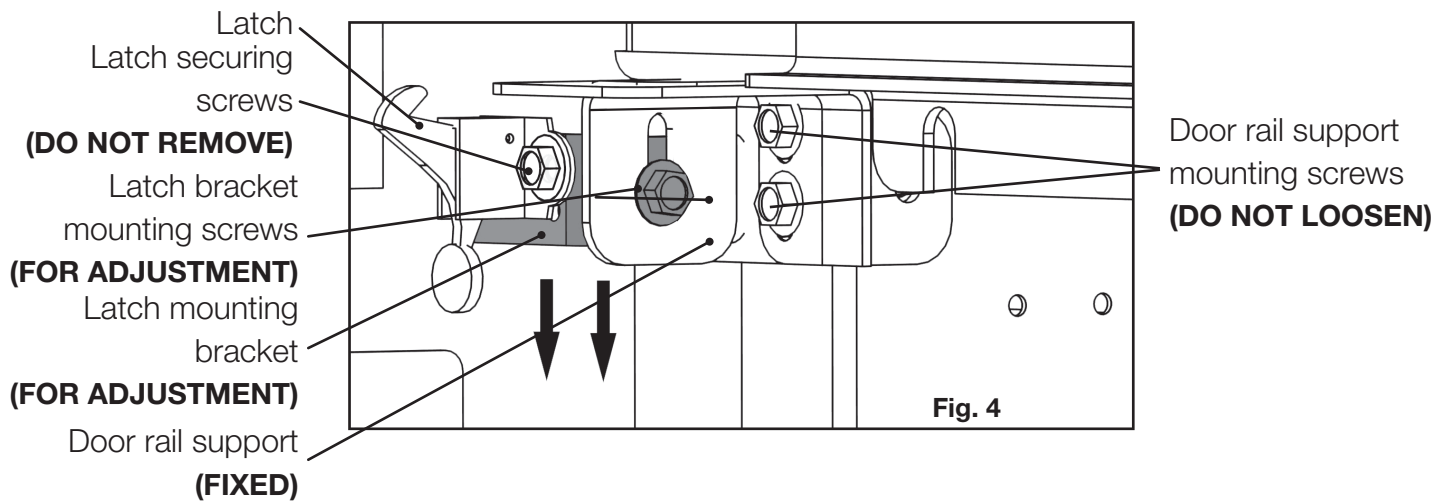

Fig. 3

4. For ease of fitting, the latch securing screws should be located at the bottom of their slots. It may be necessary to loosen the latch securing screws and slide them all the way down. Retighten the latch securing screws loosely taking care not to overtighten **(Fig. 4)**. Repeat for other end of GGA-1.

note:
DO NOT OVERTIGHTEN.



finishing

5. Fully extend the two GGA-1 slider brackets of the appliance outward (**Fig. 5**).
6. Carefully hook GGA-1 onto GGA-1 slider brackets by aligning the horizontal tabs on the GGA-1 with the horizontal slots in the bottom of the GGA-1 slider brackets and moving the GGA-1 back into the GGA-1 slider brackets (**A**). Ensure both top and bottom tabs of the GGA-1 engage with hooks of the GGA-1 slider brackets (**B**) (**Fig 5**).
7. Install 2 vertical adjustment screws underflush of GGA-1 slider bracket surface (**C**) (**Fig. 6**).

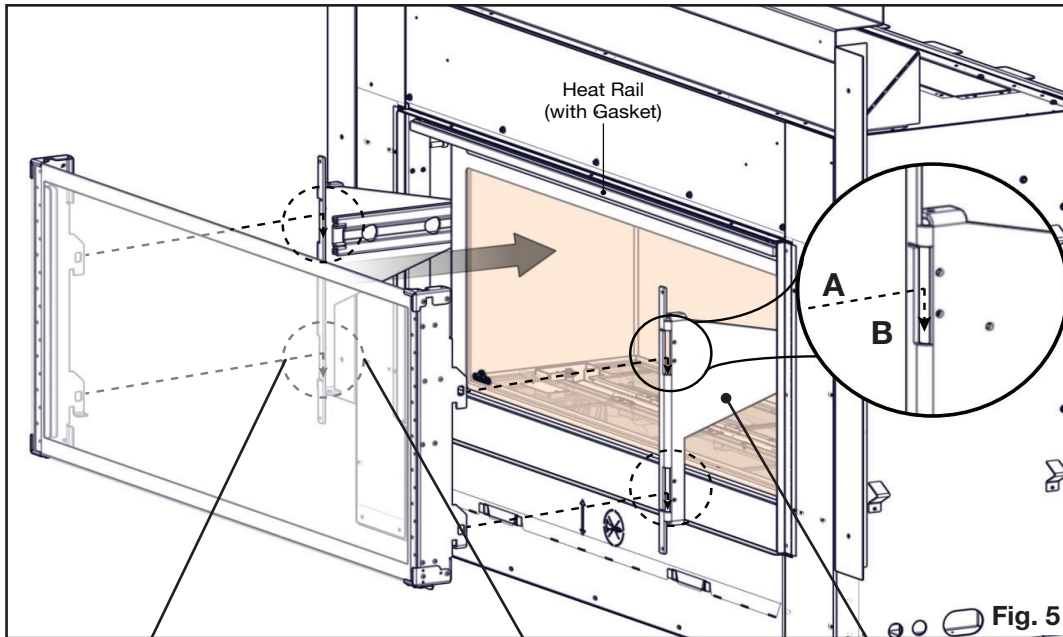

GGA-1 slider bracket

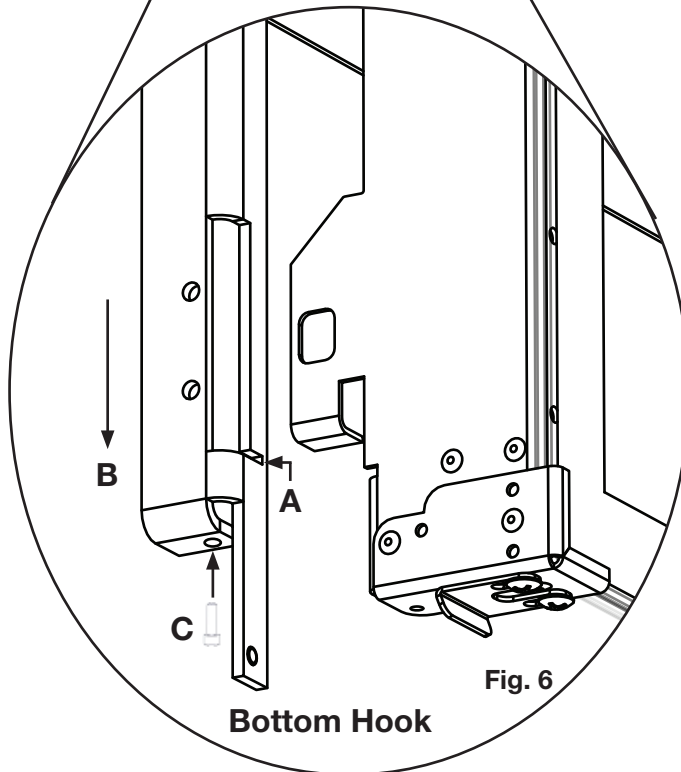

8. The GGA-1 mount bracket holes should be lined up with the screw holes of the GGA-1 slider brackets to ensure a clear line of sight (**Fig. 8**). It is typically necessary to raise the GGA-1 on both sides using the vertical adjustment screws. Raising the GGA-1 approximately 1/8" typically provides the optimum preliminary fit (**Fig. 9**). Repeat on other end of GGA-1.

DO'S

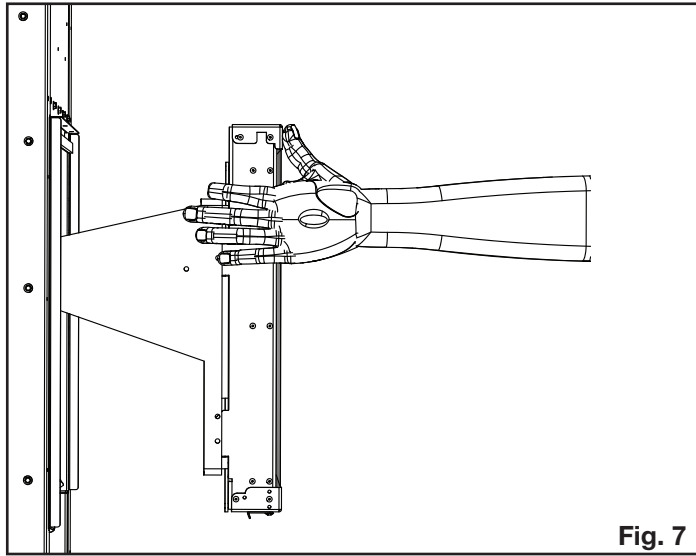

Fig. 7

Hold GGA-1 and GGA-1 slider bracket together firmly whilst tightening fasteners. Repeat on other end of GGA-1.

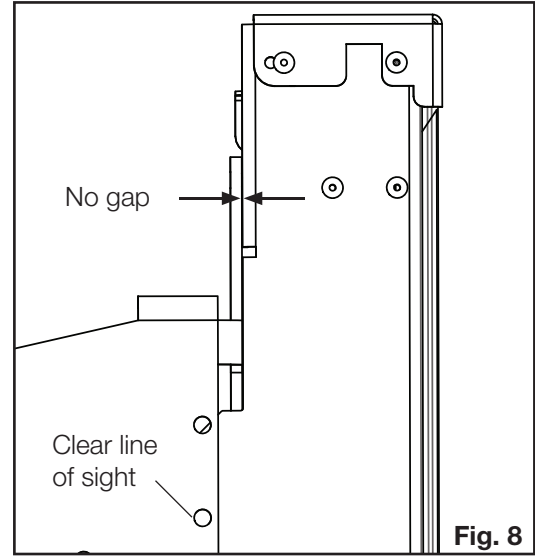

Fig. 8

Ensure there is no gap between back of GGA-1 and GGA-1 slider bracket at top and/or bottom. Repeat on other end of GGA-1.

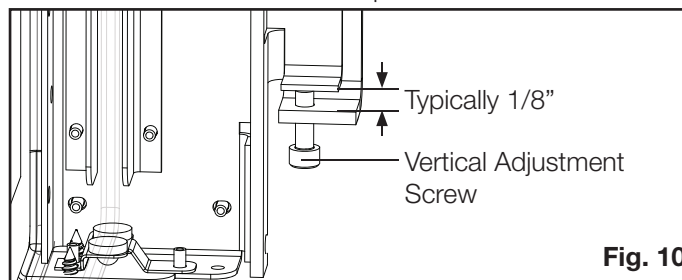

Fig. 10

DON'TS

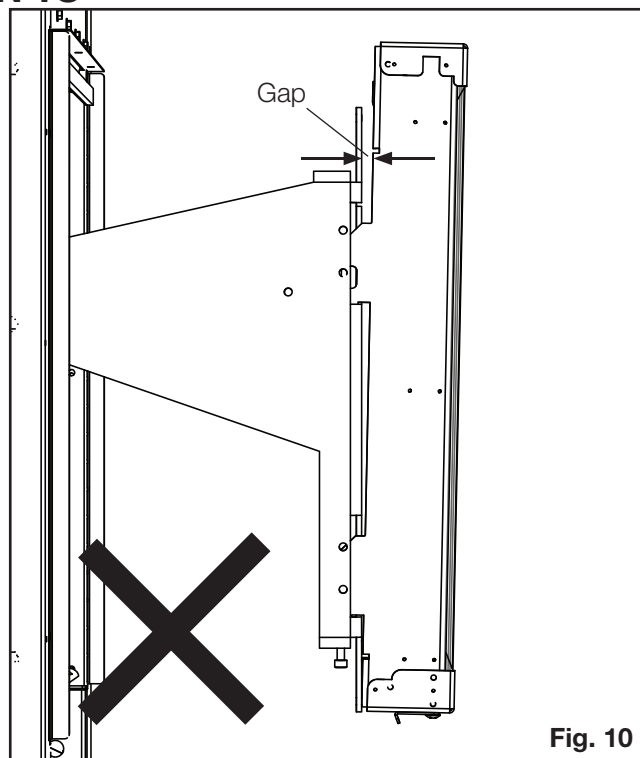

Fig. 10

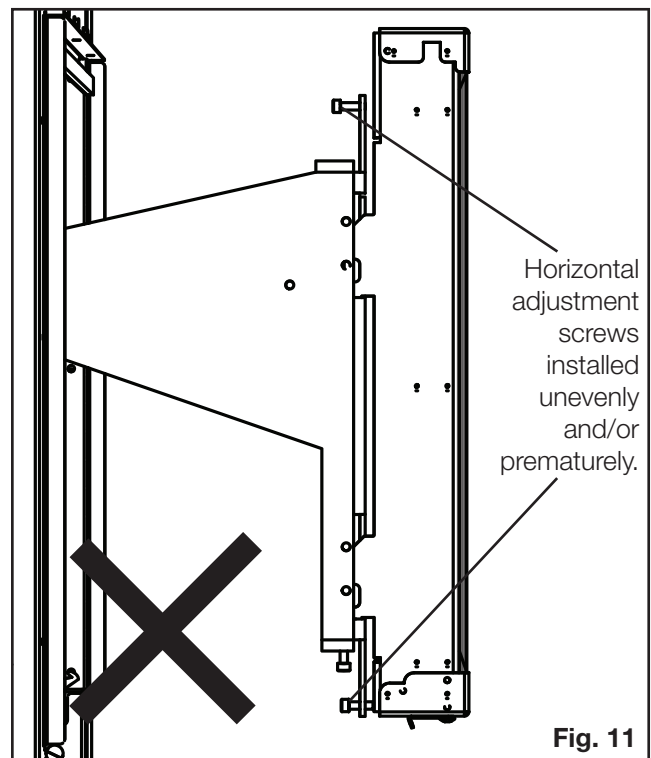

Fig. 11

finishing

9. Secure GGA-1 with 1 fastener and 1 washer on top and bottom of each GGA-1 slider bracket (total of 4) holding the GGA-1 tight to the GGA-1 slider bracket surface throughout **(Fig. 12)**. Tighten firmly enough to hold GGA-1 against GGA-1 slider bracket. Do not fully tighten until adjustment is complete and during final GGA-1 installation.

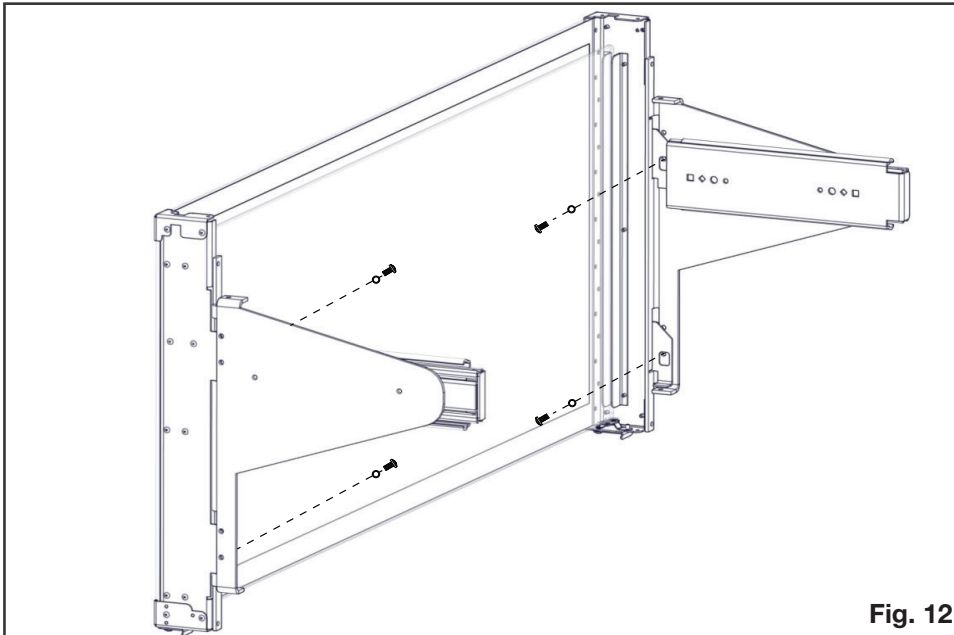

Fig. 12

10. The GGA-1 catches should be installed toward the appliance. It may be necessary to loosen the GGA-1 catch securing screws on the bottom of both sides of the GGA-1 and slide them all the way towards the back of the GGA-1. Retighten securing screws **(Fig. 13)**.

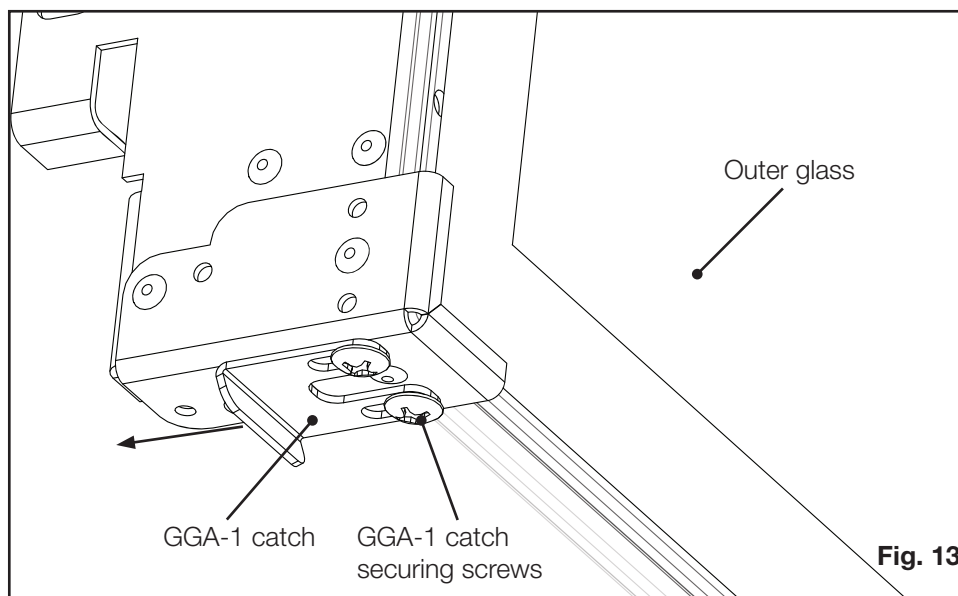

Fig. 13

- Slide the GGA-1 into the appliance until outer glass panel makes contact with heat rail gasket. The glass surface should contact the heat rail at each end (**Fig. 15**). The GGA-1 must 'click' into latches when secure. The GGA-1 must be retained by the latches and not open, if pulled. If GGA-1 does not smoothly engage with latches, an adjustment may be required, see step 13.

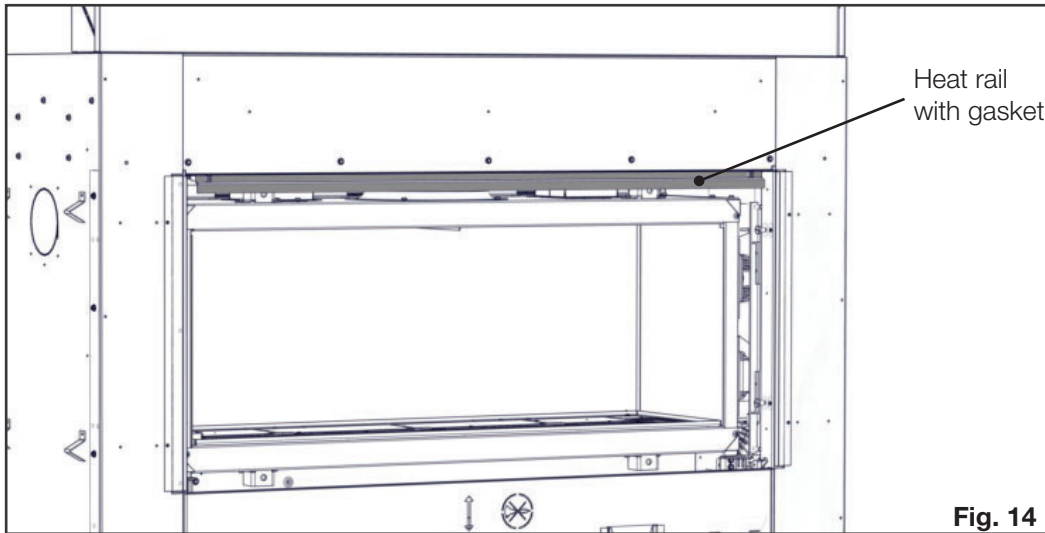

Fig. 14

important:

Ensure that the heat rail gasket is touching the both ends of the back of the outer glass as shown.

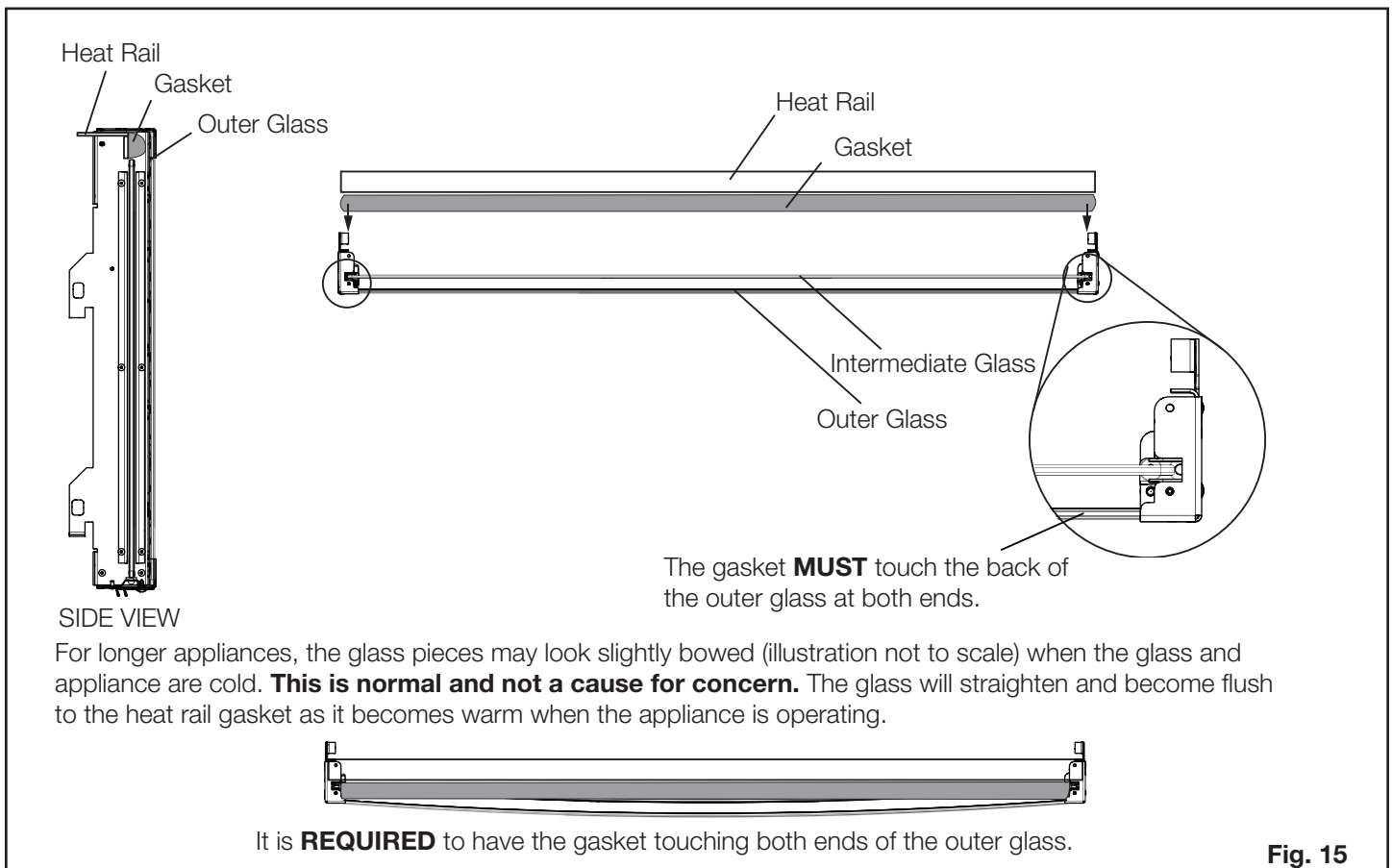

Fig. 15

! WARNING

- Normally there is no need to adjust the position of the heat rail. Contact your authorized Napoleon dealer before attempting any adjustment of the heat rail.

finishing

12. Check if the GGA-1 plane is straight. Adjust with horizontal adjustment screws on both ends, if necessary (**Fig. 16**).

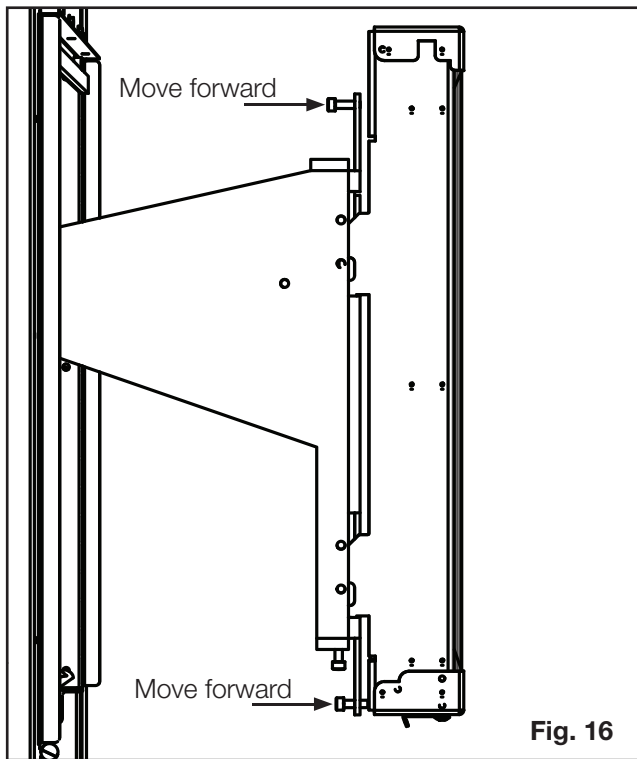

note:

If facing material is not installed plumb and square, it may be necessary to make final horizontal GGA-1 adjustments after finishing.

13. Check if the latches are correctly positioned (**Fig. 17**). Adjust latches, if necessary. Retighten the screws securely but do not overtighten.

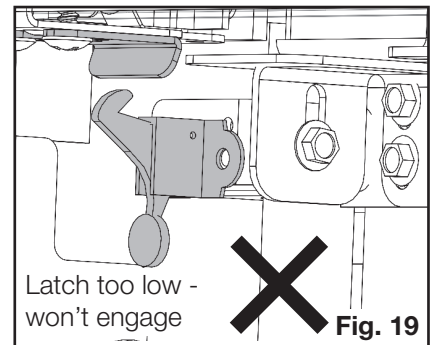
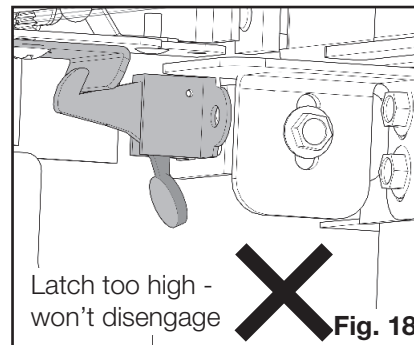
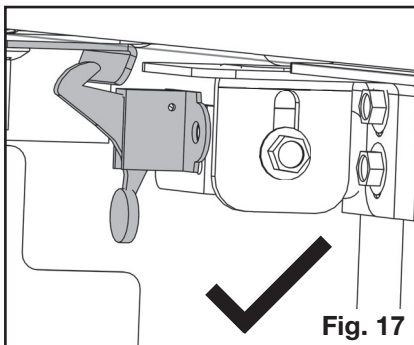

14. Recheck if the outer glass of the GGA-1 is touching the heat rail gasket on both ends.
15. Check for any excessive play by lightly pulling the GGA-1 outwards. The play (rattle / movement) should be negligible in the system when the GGA-1 is held in position by the latches.
16. If there is excessive play, the GGA-1 catches on the bottom of the GGA-1 should be adjusted forward to reduce the play to a minimal amount. This is to ensure GGA-1 can still be secured and released smoothly without excessive force **(Fig. 20)**.

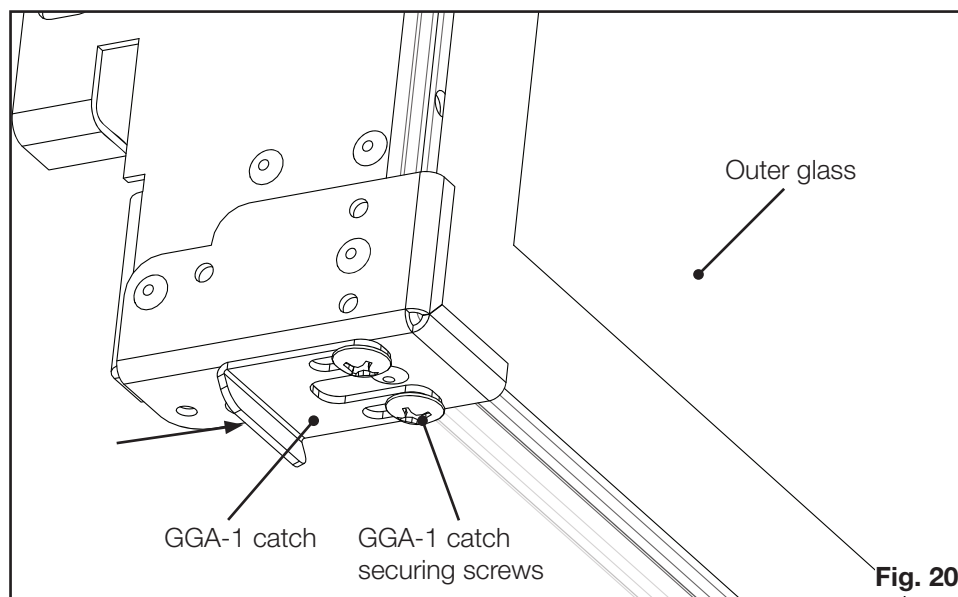
**note:**

The GGA-1 should slide smoothly back and latch with a 'click'. Front to back play should be negligible. The GGA-1 should unlatch smoothly without the need for excessive force. Continue to adjust the GGA-1 catches and/or latches until the GGA-1 can be moved correctly. Tighten all screws securely but do not overtighten.

17. Remove GGA-1 (see, "to remove GGA-1" section) and safely store the GGA-1 after preliminary adjustment. Ensure GGA-1 is placed on a non-abrasive material to avoid scratches. It is recommended to store the GGA-1 in the original packaging taking care to ensure glass surfaces are protected from scratches.
18. Re-install GGA-1 after the appliance finishing then re-check alignment.
19. Secure GGA-1 by tightening the GGA-1 slider bracket screws on both ends securely.

For see-thru models, repeat instructions for second GGA-1 to be installed on the fixed side.

finishing

To remove GGA-1

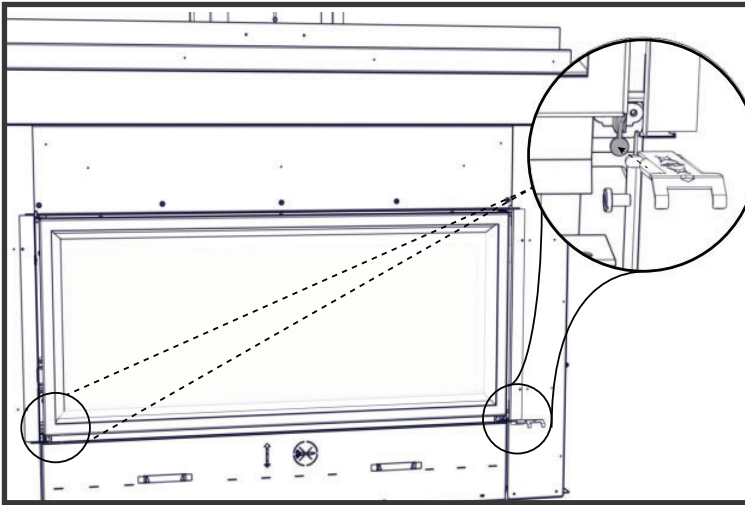

1. To open, release the latches from the GGA-1 using the release tool. Push the release tool against bottom of latch until it disengages from GGA-1. Pull gently on GGA-1 while releasing the latch.

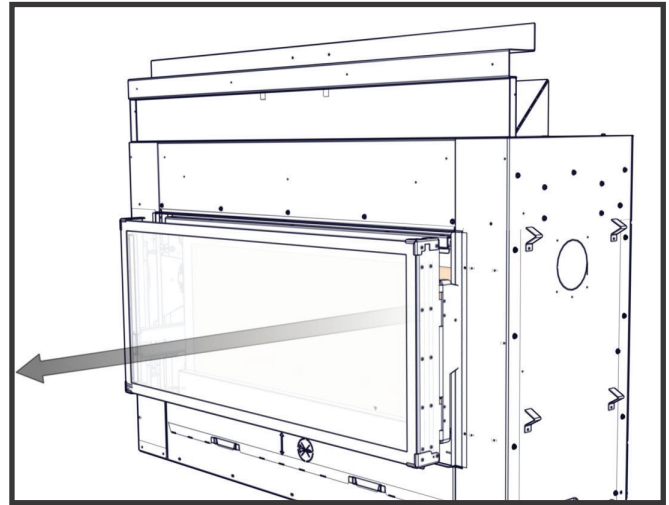

2. Pull both sides of GGA-1 keeping it parallel to the appliance.

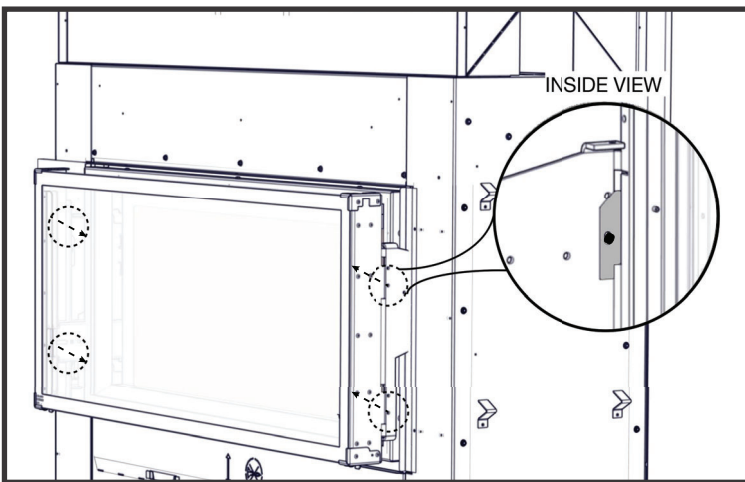

3. Remove the screws and washers securing the GGA-1 to the GGA-1 slider brackets (1 per corner, 4 total).

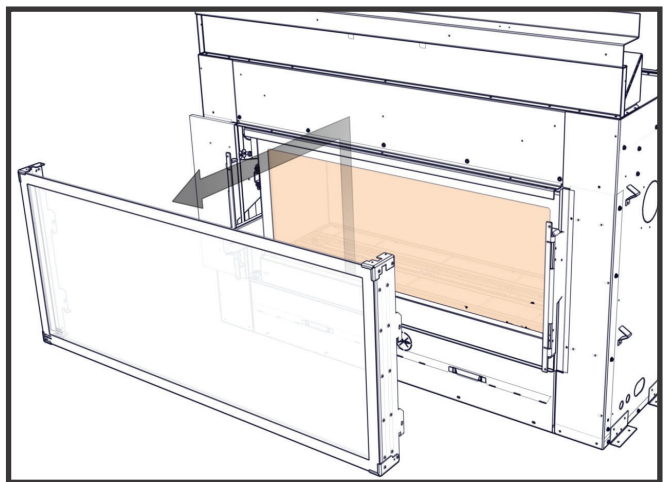

4. Carefully lift the GGA-1 up and off the GGA-1 slider brackets (2 per side). Set assembly on a clean, soft surface. Care must be taken to protect the edges of glass.

12.7 firebox glass door installation / removal

WARNING

- Do not insert fingers in the gap between the door and the door frame, or between the spring latches & door. there is a risk of injury due to the spring mechanism. Do not insert fingers in the spring door latch mechanism.

FRONT - ACCESS SIDE

- A. Remove the glass guard assembly, refer to the “glass guard installation / removal” section for details.
- B. Remove the door trim by carefully lifting it up and off from behind the bottom frame of the glass door.

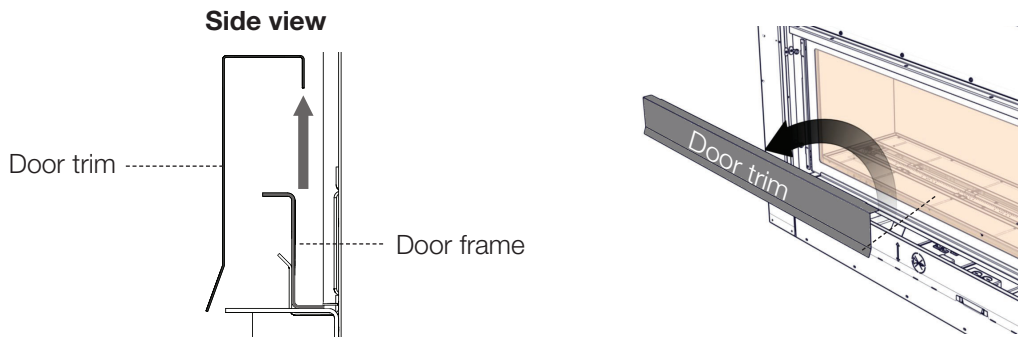

LVX38-1 Illustrated

- C. For door removal, locate the top and bottom door latches. Pull latches forwards and away to disengage door latches.

note:

Ensure to leave one hand on the glass door during entire door removal.

- D. Tilt the top of the door forwards 90 degrees, then lift it up and out of the door latches.
- E. Reverse these steps to re-install the door, ensure the top and bottom door latches are properly engaged prior to releasing the door (number of latches varies by size of appliance).

note:

Ensure the door opens freely and closes sealed.

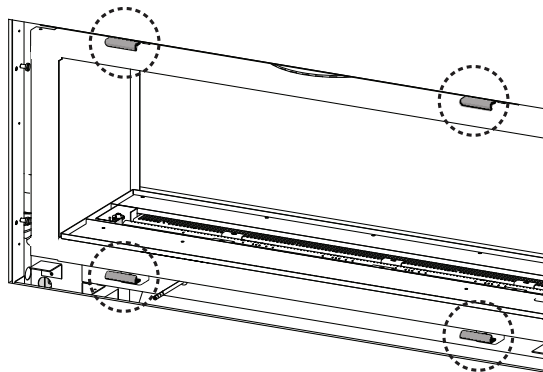

LVX38-1 Illustrated

IMPORTANT: Once latches are engaged, test to make sure that the door is sealed.

finishing

FIXED - SEE-THRU ONLY

- F. Remove GGA-1 from fixed side.
- G. Remove the screws securing the door to the appliance.
- H. Tilt the top of the door forward, then lift it up and out of the bottom door retainer.
- I. When re-installing the door, lift onto the bottom door retainer, tilt the top towards the appliance and secure with the previously removed screws.

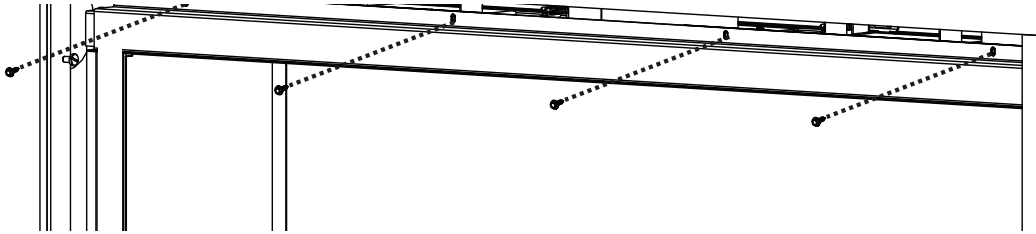

note:

Under normal conditions, there is no reason to remove the fixed side of the firebox glass door. Servicing can be completed from the access side.

12.8 media tray removal

It is recommended to **only** install media trays **when using sand as media**. Media trays, where supplied, should be stored in the event it is planned to install alternate media at some point in the future.

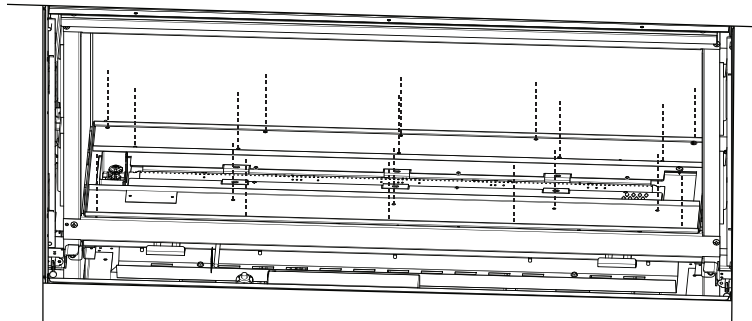

12.9 media installation / removal

! WARNING

- Clean the glass media prior to installation. Before applying the cleaned glass, ensure that it is dry.
- If replacing, use only the replacement glass media available from your local authorized dealer / distributor.
- Glass media over the burner ports will cause flame lifting and sooting problems.
- Do not place any media (glass or vermiculite) in or around the pilot opening and/or on the burner ports. This will interfere with the pilot operation.

Cleaning Glass Media

Glass media may have a fine oil residue that needs to be cleaned prior to installation. Clean the glass with mild dish soap, drain, rinse thoroughly and dry before placing over the burner.

note:

Do not use more media than what was supplied with the appliance. Do not place media directly onto the burner **(NG models only)**.

Unless using sand as media, it is recommended **NOT** to use the media trays. Not only will this provide a clean look to the appliance, but it also results in a most pleasing and clean-burning flame. Media trays should be stored in the event it is planned to install alternate media at some point in the future.

Media should be installed across the burner tray and a small to moderate amount of media placed on the burner itself and, if necessary, adjusted to achieve a pleasing flame appearance. **Never place excessive media on the burner as this can result in carboning or an unappealing flame characteristic. For smaller units, it is recommended not to put media on the burner ports themselves as the difference in flame pattern can be particularly noticeable.**

Never place media in the pilot housing or over the pilot. Ensure no glass or media falls into the pilot opening. If this happens, insert a clean bag into your vacuum cleaner and vacuum out the media. Replacement media can be purchased from your local dealer / distributor.

Always check that the appliance ignites smoothly across the entire burner to ensure media placement does not compromise performance. Pay particular attention when using power vents to ensure media placement does not affect ignition or flame characteristics. Adjust the air shutter according to the table under "venturi adjustment". Undesirable differences in the flame pattern result from excessive or inconsistent / incorrect placement of media on the burner.

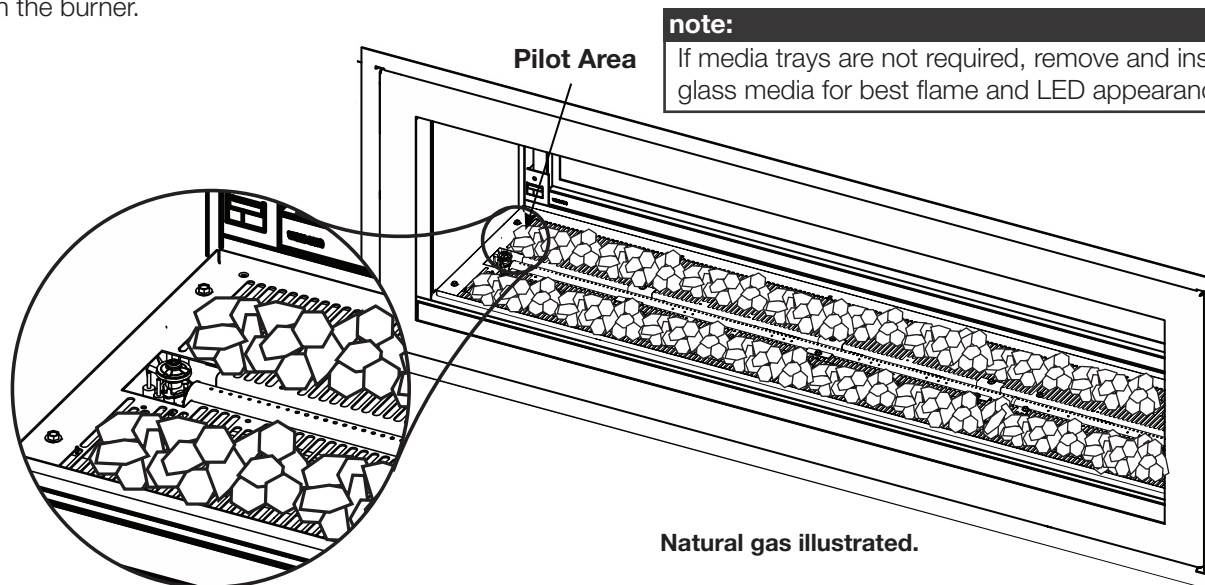

note:

Do not place media directly over peaks, see "flame characteristics" section for more information.

This appliance comes equipped with a media tray for sand over top the media tray with opening for use with all other types of media. Unless, installing sand media, remove the sand media trays.

13.0 adjustments

13.1 restricting vertical vents

Vertical installations may display a very active flame. If this appearance is not desirable, the vent exit in the appliance must be restricted using a restrictor vent kit. Refer to the “**replacement parts**” section of the owner’s manual for the appropriate kit. This will reduce the velocity of the exhaust gases, slowing down the flame pattern and creating a more traditional gentle flame appearance. Specific instructions are included with the kit.

13.2 venturi adjustment

This appliance is equipped with an externally adjustable air shutter that is **not** preset from factory. Any adjustments made to the shutter **must** be done with door installed, including the burner and all media installed into the appliance. It is important to operate the appliance and verify that the air shutter is opened to the correct amount to prevent either flame lifting or carbonizing and to optimize the appearance of the flame. To open or close the shutter, pull the rod away from the appliance or push the rod towards the appliance respectively.

Small adjustments on the shutter can have a drastic effect on the flame appearance; it is recommended to adjust the shutter in 1/8” increments.

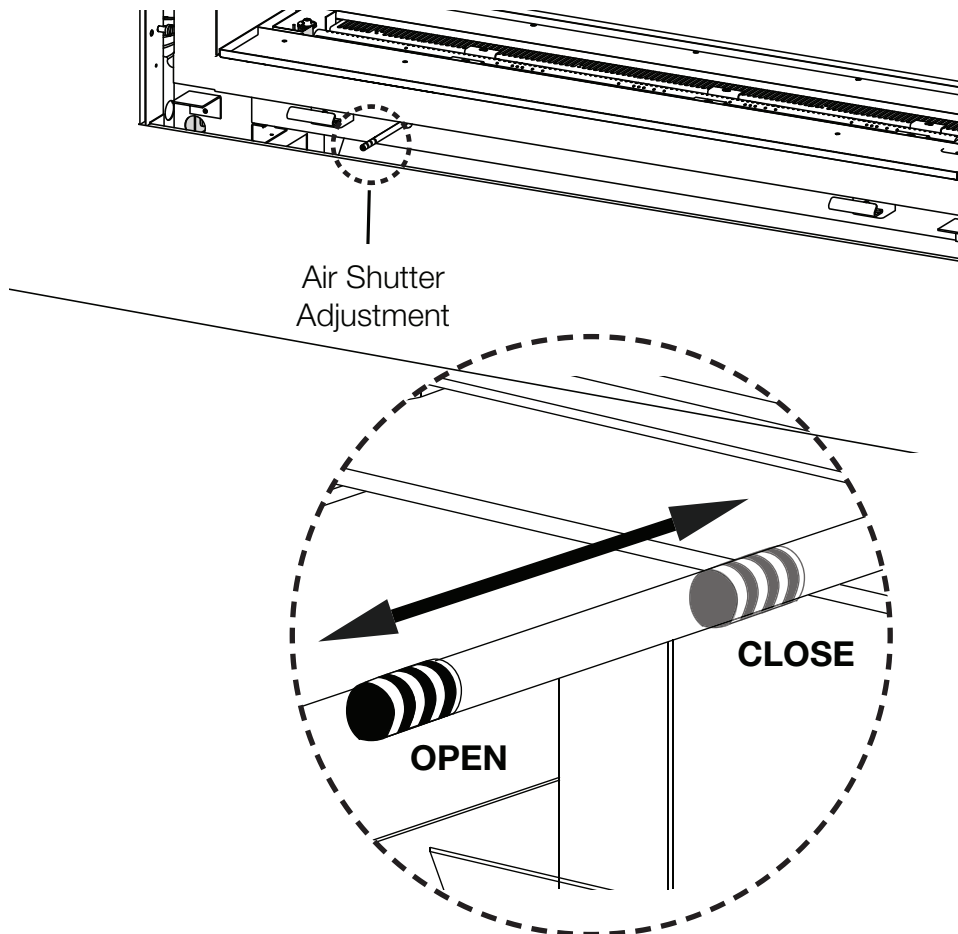

! WARNING

- Air shutter adjustment must be done by a qualified installer

Regardless of air shutter location closing the air shutter will cause a more yellow flame, but can lead to carbonization. Opening the air shutter will cause a more blue flame, but can cause flame lifting from the burner ports. The flame may not appear yellow immediately, allow 15 to 30 minutes for the flame colour to be established.

13.3 pilot burner adjustment

Adjust the pilot screw to provide properly sized flame. Turn in a clockwise direction to reduce the gas flow.

Check Pressure Readings:

Inlet pressure can be checked by turning screw (A) counter-clockwise 2 or 3 turns and then placing pressure gauge tubing over the test point. Gauge should read as described on the chart below. Check pressure with main burner operating on "HI".

Outlet pressure can be checked the same as above using screw (B). Gauge should read as described on the chart below. Check pressure with main burner operating on "HI".

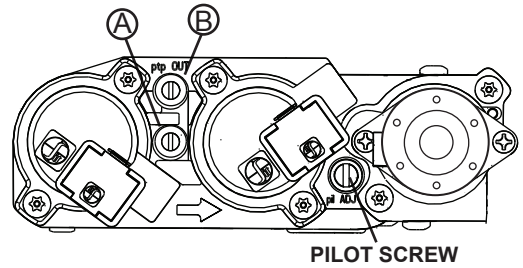

After taking pressure readings, be sure to turn screws clockwise firmly to reseal. Do not overtorque.

Leak test with a soap and water solution.

Prior to pilot adjustment, ensure that the pilot assembly has not been painted. If overspray or painting of the pilot assembly has occurred remove the paint from the pilot assembly, or replace. Fine emery cloth or a synthetic scrub pad (such as Scotch-Brite™) can be used to remove the paint from the pilot hood, electrode and flame sensor.

	Natural Gas	Propane
Min. Inlet Gas Supply Pressure	4.5" w.c. (11mb)	11" w.c. (27mb)
Max. Inlet Gas Supply Pressure	*13" w.c. (32mb)	13" w.c. (32mb)
Manifold Pressure (Under Flow Conditions)	3.5" w.c. (9mb)	10" w.c. (25mb)

***Maximum inlet pressure not to exceed 13"**

13.4 flame characteristics

It's important to periodically perform a visual check of the pilot and burner flames. Compare them to the illustration provided. If any flames appear abnormal, call a service person.

If media trays are not required, remove and install glass media for best flame and LED appearance.

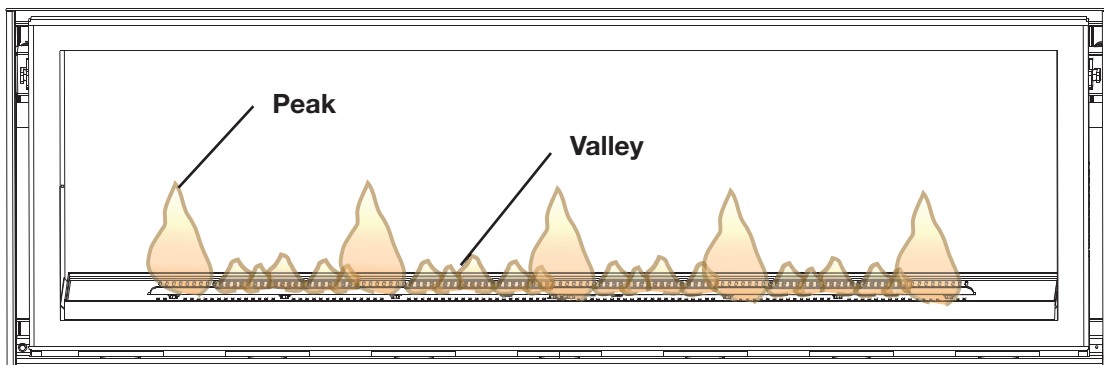
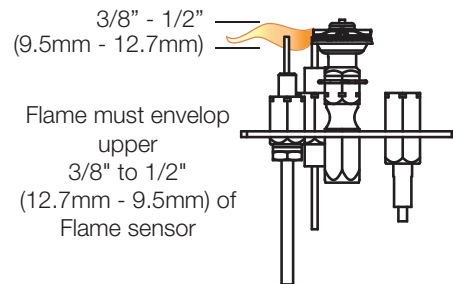

LVX50-1 Illustrated

14.0 maintenance

WARNING

- Turn off the gas and electrical power before servicing the appliance.
- Appliance may be hot. Do not service until appliance has cooled.
- Do not use abrasive cleaners on glass.
- Do not paint the pilot assembly.

This appliance and its venting system should be inspected before use and at least annually by a qualified service person. The following suggested checks should be performed by a qualified technician. The appliance area must be kept clear and free of combustible materials, gasoline, or other flammable vapors and liquids. The flow of combustion and ventilation air must not be obstructed.

note:

Caution: Label all wires prior to disconnection when servicing controls. Wiring errors can cause improper and dangerous operation. Verify proper operation after servicing.

1. In order to properly clean the burner and pilot assembly, remove the logs, rocks and/or glass to expose both assemblies.
2. Keep the control compartment, media, burner, air shutter opening and the area surrounding the appliance clean by vacuuming or brushing, at least once a year.
3. Check to see that all burner ports are burning. Clean out any of the ports which may not be burning or are not burning properly.
4. Check to see that the pilot flame is large enough to engulf the flame sensor and/or thermocouple / thermopile as well as it reaches the burner.
5. If your appliance is equipped with a safety barrier, cleaning may be necessary due to excessive lint / dust from carpeting, pets, etc. simply vacuum using the brush attachment.
6. If your appliance is equipped with relief doors, ensure the system performs effectively. Check that the gasket is not worn or damaged. Replace if necessary.
7. Replace the cleaned logs, rocks or glass. Failure to properly position the media may cause carboning which can be distributed in the surrounding living area, inside the firebox and on exterior surfaces surrounding vent termination.
8. Check to see that the main burner ignites completely on all ports when turned on. A 5 to 10 second total light-up period is satisfactory. If ignition takes longer, consult your local authorized dealer / distributor.
9. Visually inspect the appliance for carbon build up. Using a small whisk or brush, brush off the carbon and vacuum up or sweep into garbage.
10. **This step is not applicable for Vent Free appliances:** Check to see that the appliance is venting correctly. Ensure chimney system is safe and unobstructed. (If for any reason the vent air intake system is disassembled, re-install and re-seal per the instructions provided for the initial installation).

14.1 annual maintenance

! WARNING

- Annual maintenance should be performed by a qualified service technician
- The firebox becomes very hot during operation. Let the appliance cool completely or wear heat resistant gloves before conducting service.
- Never vacuum hot embers.
- Do not paint the pilot assembly

- This appliance will require maintenance which should be planned on an annual basis.
- Service should include cleaning, battery replacement, venting inspection and inspection of the burner, media, and firebox. Refer to the door removal section and remove the door as instructed.
- Carefully remove media if necessary (logs, glass, brick panels, etc.).
- Using a vacuum with soft brush attachment, gently remove any dirt, debris, or carbon build up from the logs, firebox, and burner. For glass media, follow the installation instructions for pre-cleaning.
- Gently remove any build-up on the pilot assembly including thermopile, thermocouple, flame sensor, and igniter (if equipped).

note:

Clean flame sensor using a fine emery cloth or a synthetic scrub pad (such as Scotch-Brite™) to remove any oxides. Clean the pilot assembly using a vacuum with a soft brush attachment. It is important that the pilot assembly is not painted.

- Inspect all accessible gaskets and replace as required.
- If equipped with a blower, access the blower and clean using a soft brush and vacuum.
- Re-assemble the various components in reverse order.
- Inspect the relief system. The appliance relieves through the main glass door or through the flaps on the firebox top. Ensure they open freely, and close sealed.
- Check the gas control valve pilot and Hi / Lo knobs move freely, if equipped. Replace if any stiffness in movement is experienced.
- Check for gas leaks on all gas connections up and downstream from the gas valve including pilot tube connections.

14.2 control access

Access to the control can be done through the firebox by removing the glass guard assembly, glass door and front trim.

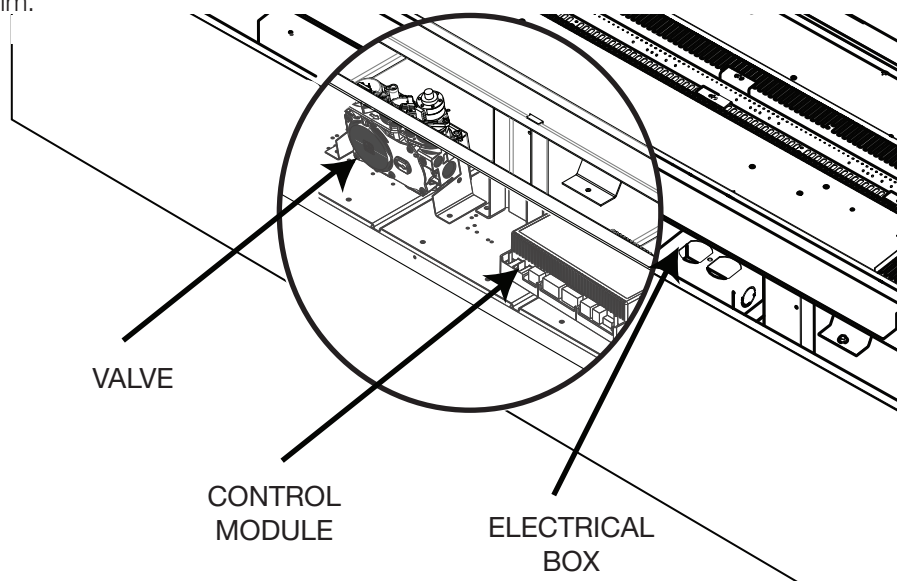

maintenance

14.3 burner removal

- A. Remove the GGA-1 and glass door, refer to the “glass guard installation / removal” & “door installation / removal” sections for details.
- B. Remove the control cover from the appliance by sliding it up and out of the clips of the front cover.
- C. Remove the media from the appliance.
- D. Remove the pilot housing by removing the screws.
- E. Remove the screws that secure the media tray in place. Lift the burner assembly up and out of the appliance.

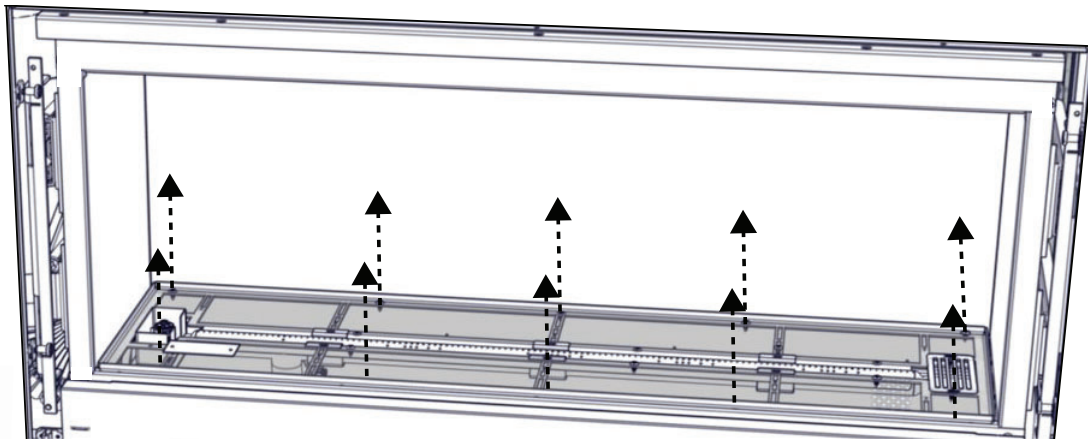

LVX38-1 Illustrated

14.4 valve removal

- A. Remove the GGA-1 and glass door, refer to the “glass guard installation / removal” & “door installation / removal” sections for details.
- B. Remove the control cover from the appliance by sliding it up and out of the clips of the front cover.
- C. Remove the media tray and burner assembly, refer to the “burner removal” section for details.

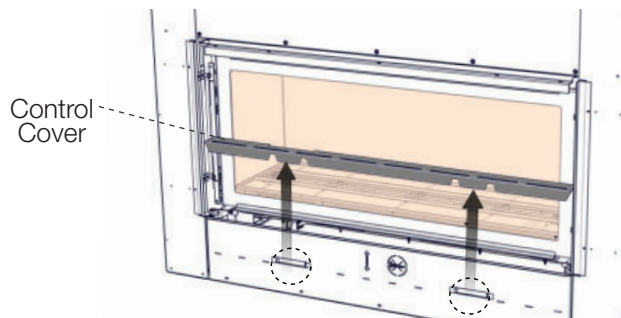

- D. Disconnect the flex connector from the valve. Remove the valve wire connections, labeling each one to aid with re-connection.
- E. Remove the screws from the valve bracket and remove the valve.
- F. Replace all components before returning the appliance to service.
- G. Check for gas leaks by brushing on a soap and water solution.

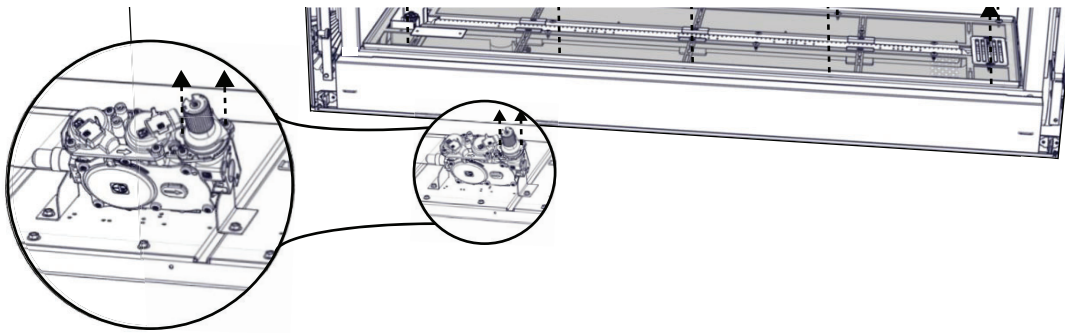

14.5 control module removal

- A. Remove the GGA-1 and glass door, refer to the “glass guard installation / removal” & “door installation / removal” sections for details.
- B. Remove the control cover from the appliance by sliding it up and out of the clips of the front cover.
- C. Remove the two screws holding the control module in place, unplug and remove.
- D. Ensure to identify the wires plugged into the control module. It is critical that wires are reconnected to the appropriate connectors.
- E. Replace and reinstall components.

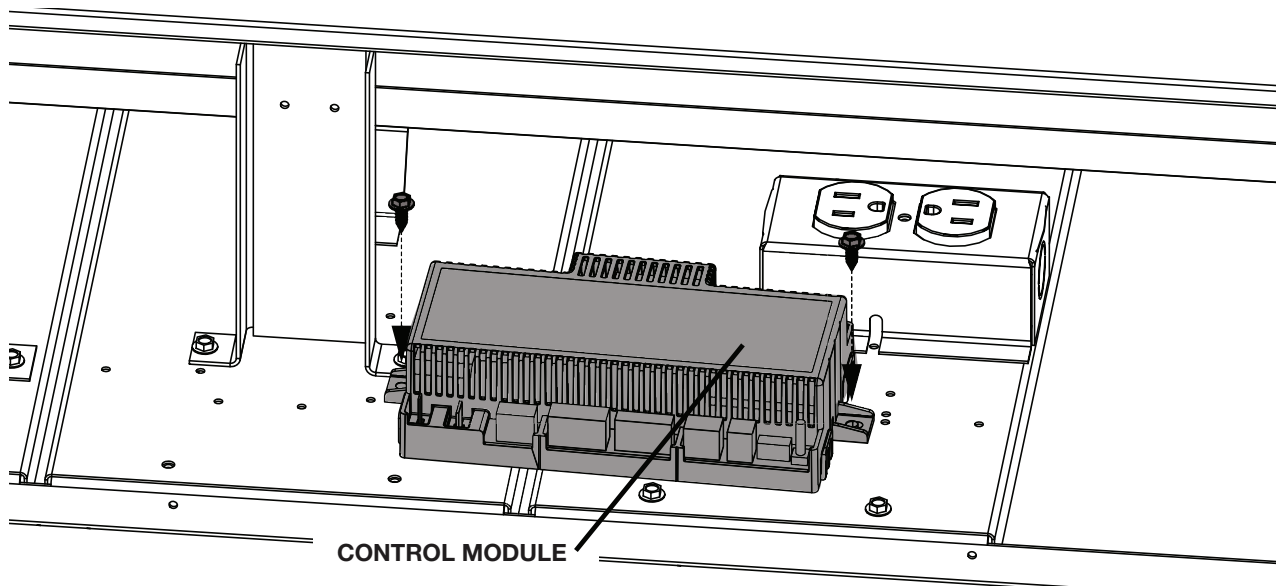

maintenance

14.6 LED replacement

This appliance comes equipped with an LED strip. If in the event the LED strip needs to be replaced, follow these instructions.

- A. Turn off all electrical supply.
- B. Remove the GGA-1 and glass door, refer to the “Glass Guard installation/removal” & “door installation/removal” sections for details.
- C. Remove the control cover from the appliance by sliding it up and out of the clips of the front cover.
- D. Remove the media tray and burner assembly, refer to the “burner removal” section for details.
- E. Unplug the LED strip from the control module.
- F. Remove the LED glass by removing the screws securing the LED frame in place, then lift it up and out of the appliance.
- G. Remove the LED strip by removing the four securing screws, replace and reinstall components.

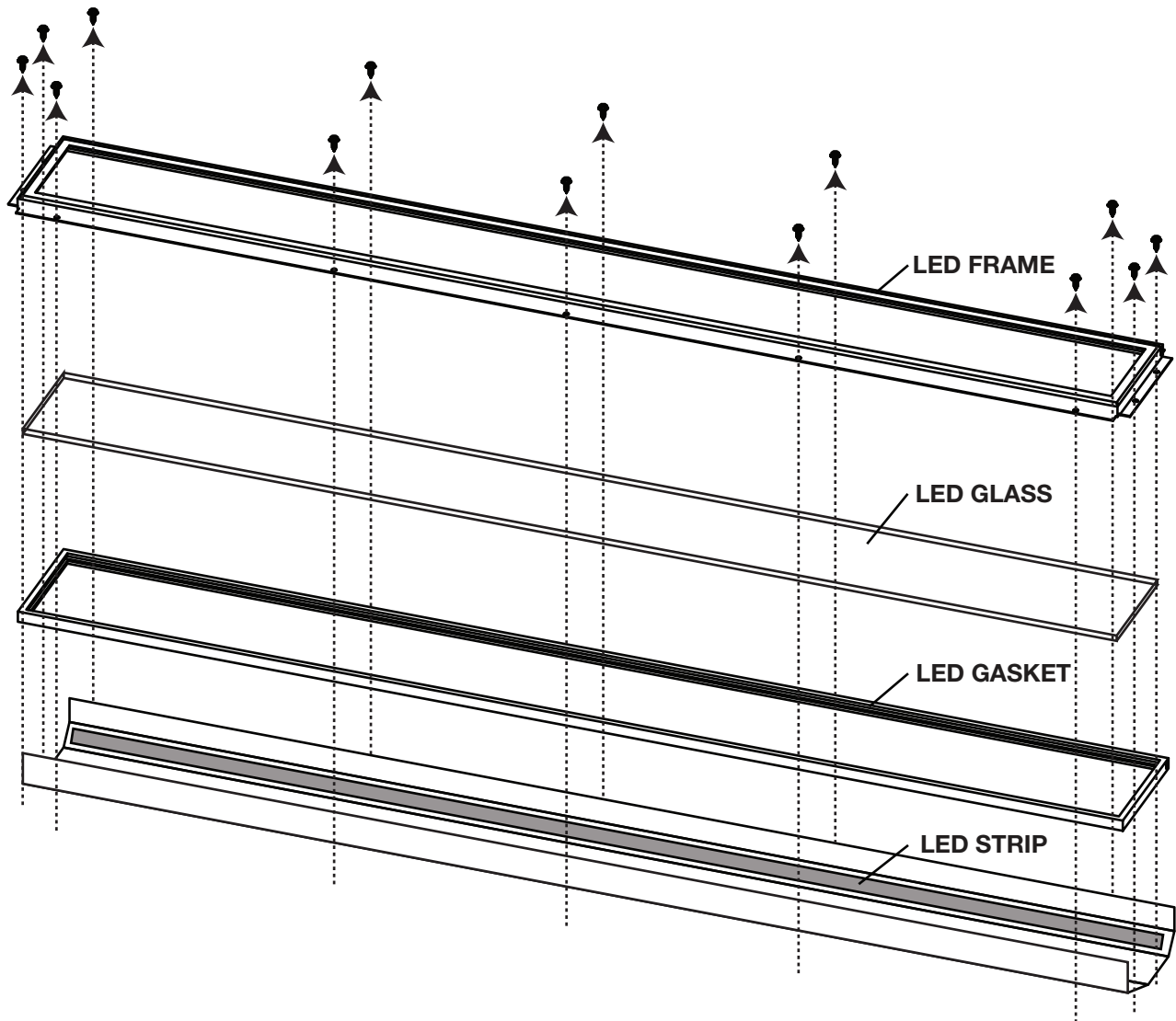

LVX38-1 Illustrated

14.7 glass / door replacement

WARNING

- Do not use substitute materials.
- Glass may be hot. Do not touch glass until cooled.
- Care must be taken when removing and disposing of any broken door glass or damaged components. Be sure to vacuum up any broken glass from inside appliance before operation.
- Do not strike, slam, or scratch. Do not operate appliance with glass removed, cracked, broken, or scratched.

Replacement glass/frame assembly shall be replaced as a complete unit as supplied by the appliance manufacturer.

14.8 care of glass

WARNING

- Do not clean glass when hot! Do not use abrasive cleaners to clean glass.

Buff lightly with a clean dry soft cloth to remove accumulated dust or fingerprints. Clean both sides of the glass after the first 4 hours of operation with an ammonia-free glass cleaner.

note:

Vinegar-based glass cleaners have demonstrated an ability to provide a clean, streak free glass surface.

Thereafter, clean as required. If the glass is not kept clean permanent discoloration and / or blemishes may result. Contact you local authorized dealer / distributor for complete cleaning instructions.

Razor blades, steel wool, or other metallic objects must not be used on both surfaces of the glass. Doing so can remove a thin layer of metal from the razor blades, steel wool, or other metallic objects that may then be deposited onto the coating. This can result in a discoloured stain or scratch-like mark. More importantly, this can scratch the glass surface, thereby reducing its strength.

Do not operate the appliance with broken glass, as leakage of flue gases may result.

Contact your local authorized dealer / distributor for complete cleaning instructions.

If the glass should ever crack or break while the fire is burning, do not open the door until the fire is out. Do not operate the appliance until the glass has been replaced. Contact you local authorized dealer / distributor for

14.9 care of plated parts

If the appliance is equipped with plated parts, you must clean fingerprints or other marks from the plated surfaces before operating the appliance for the first time. Use an ammonia-free or vinegar-based cleaner and a towel to clean. If not cleaned properly before operating for the first time, the marks can cause permanent blemishes on the plating. After the plating is cured, the fingerprints and oils will not affect the finish and little maintenance is required, just wipe clean as needed. Prolonged high temperature burning with the door ajar may cause discoloration on plated parts.

note:

The protective wrap on plated parts is best removed when the assembly is at room temperature but this can be improved if the assembly is warmed (i.e. using a hair dryer or similar heat source).

This appliance is factory equipped with 5mm ceramic glass. Use only replacement parts as supplied by the appliance manufacturer. **DO NOT SUBSTITUTE MATERIALS**

15.0 replacement parts

WARNING

- Failure to position the parts in accordance with this manual or failure to use only parts specifically approved with this appliance may result in property damage or personal injury.

Contact your dealer for questions concerning prices and policies on replacement parts. Normally, all parts can be ordered through your Authorized dealer / distributor.

For warranty replacement parts, a photocopy of the original invoice will be required to honour the claim.

When ordering replacement parts always give the following information:

- Model & Serial Number of appliance
- Installation date of appliance
- Part number
- Description of part
- Finish

Parts, part numbers, and availability are subject to change without notice.

Parts identified as stocked will be delivered within 2 to 5 business days for most delivery destinations.

Parts not identified as stocked will be delivered within a 2 to 4 week period, for most cases.

Parts identified as 'SO' are special order and can take up to 90 days for delivery.

15.1 overview

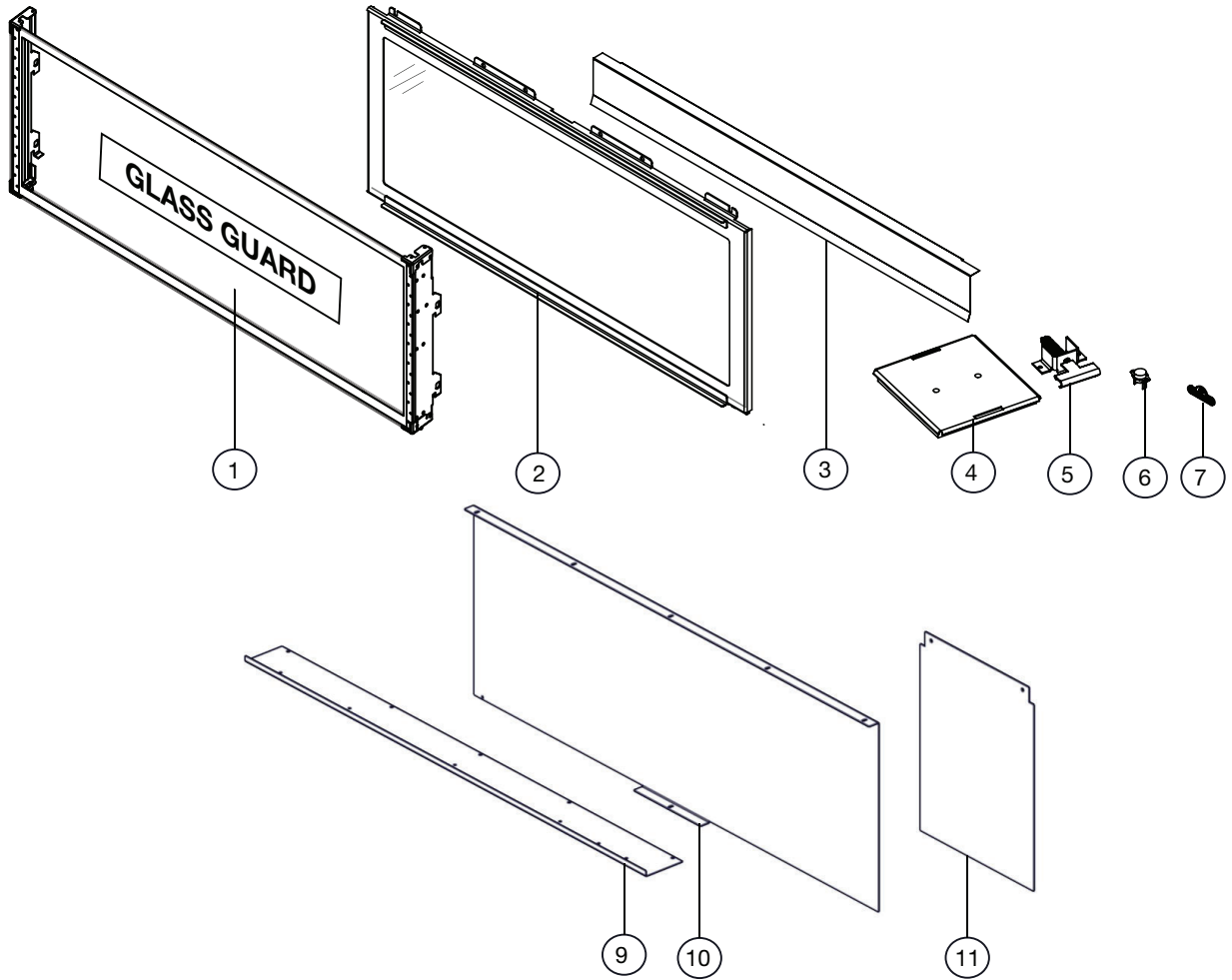

Items may not appear exactly as illustrated

REF. #	Description	Part Number				Stocked
		LVX38-1	LVX50-1	LVX62-1	LVX74-1	
1	Glass Guard Assembly	GGA38-1	GGA50-1	GGA62-1	GGA74-1	
2	Fixed Door Assembly	W010-4198-SER	W010-4162-SER	W010-4202-SER	W010-4090-SER	
2	Access Door Assembly (See-thru)	W010-4198-SER	W010-4162-SER	W010-4202-SER	W010-4090-SER	
3	Door Trim	W715-1158-SER	W715-1159-SER	W715-1162-SER	W715-1163-SER	
4	Relief Door Assembly	N/A	W010-1426			
5	Door Latch Assembly	W010-3554				
6	High Limit Switch	W660-0204				
7	Napoleon Logo	W385-2010				Yes
*8	Heat Rail (w/ gasket)	W010-4257-SER	W010-4258-SER	W010-4259-SER	W010-4260-SER	
9	Media Tray	W710-0104-SER	W710-0107-SER	W710-0099-SER	W710-0098-SER	
10	Porcelain End Panel	W475-1031-BK2GL-SER				
11	Porcelain Panel (Rear)	W475-1409-BK2GL-SER	W475-1419-BK2GL-SER	W475-1422-BK2GL-SER	W475-1414-BK2GL-SER	
12	Latch, elbow	W390-0034				
13	Gasket, silicone glass seal	W290-0383-SER				

*Part not illustrated

replacement parts

15.2 burner components

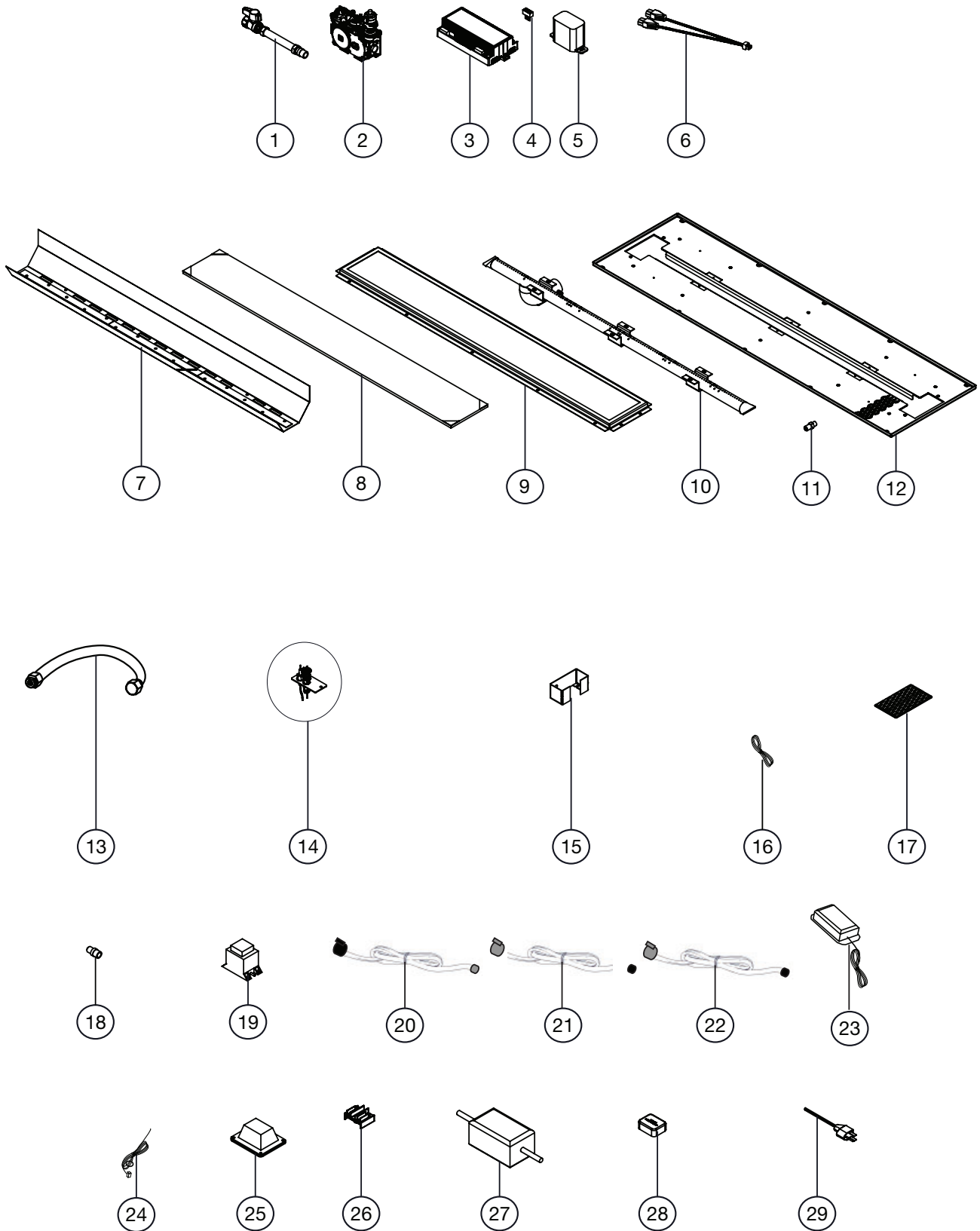

Items may not appear exactly as illustrated

Ref. #	Description	Part Number				Stocked
		LVX38-1	LVX50-1	LVX62-1	LVX74-1	
1	Flex Connector (c/w Shut-Off)	W175-0217				Yes
2	Valve (NG)	W725-0056				Yes
	Valve (P)	W725-0057				Yes
3	Control Board	W190-0177				Yes
4	Control Board Wiring Harness	W750-0276				Yes
5	Battery Housing	W350-0655				Yes
6	3 Prong Light Pigtail	W750-0358				Yes
7	LED Light Assembly	W010-3661-SER	W010-3652-SER	W010-4079-SER	W010-4078-SER	
8	LED Glass Assembly	W010-3752-SER	W010-3714-SER	W010-4071-SER	W010-4070-SER	
9	LED Cover	W200-0543-SER	W200-0499-SER	W200-0653-SER	W200-0652-SER	
10	Burner Assembly (NG)	W100-0225-SER	W100-0224-SER	W100-0221-SER	W100-0226-SER	
	Burner Assembly (P)	W100-0232	W100-0234	W100-0233	W100-0269	
11	Burner Orifice (NG)	W456-0037	W456-0033	W455-0144	W455-0141	Yes
	Burner Orifice (P)	W456-0053	W456-0052	W456-0051	W456-0049	
12	Media Tray Assembly	W010-4140-SER	W010-4139-SER	W010-4136-SER	W010-4138-SER	
13	Manifold (Flex)	W432-0533				
14	Pilot Assembly (NG)	W010-2763				Yes
	Pilot Assembly (P)	W010-2808				Yes
15	Pilot Housing	W350-0800-SER				
16	PF2 Wire Harness	W750-0276				Yes
17	Media Cover Assembly	W010-4211-SER				
18	Connector	W445-0038				Yes
19	Transformer	W707-0019				Yes
20	LED Wire (Black)	W750-0432		W750-0433		
21	LED Wire (White)	W750-0430	W750-0401	W750-0430	W750-0401	
22	LED Aux Wire	W750-0434				
23	LED Controller	W190-0125				
24	Bluetooth Wire Harness	W750-0435				
25	Light, Accent	W405-0096-SER				Yes
26	Terminal	N/A		W060-0008		Yes
27	Transformer (Night Light)	W707-0019		W707-0027		Yes
28	Bluetooth Module	W190-0090				Yes
29	Power Cord	W750-0294				

16.0 troubleshooting

! WARNING

- Always light the pilot whether for the first time or if the gas supply has run out, with the glass door open or removed.
- Turn off gas and electrical power before servicing the appliance.
- Appliance may be hot. Do not service until appliance has cooled.
- Do not use abrasive cleaners

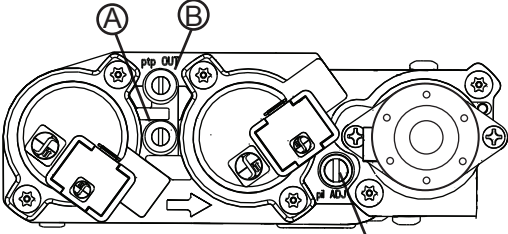
symptom	problem	test solution
Main burner flame is a blue, lazy, transparent flame. (This is not applicable in outdoor appliances)	Blockage in vent. Incorrect installation.	- Remove blockage. In really cold conditions, ice buildup may occur on the terminal and should be removed as required. (To minimize this from reoccurring, the vent lengths that pass through unheated spaces (attics, garages, crawl spaces) should be wrapped with an insulated mylar sleeve). - Refer to “venting” section to ensure correct installation.
Flames are consistently too large or too small. Carboning occurs.	Appliance is over-fired or under-fired.	- Check pressure readings: Inlet pressure can be checked by turning screw (A) counter-clockwise 2 or 3 turns and then placing pressure gauge tubing over the test point. Gauge should read as described on the chart below. Check that main burner is operating on ‘HI’. Outlet pressure can be checked the same as above using screw (B). Gauge should read as described on the chart below. Check that main burner is operating on ‘HI’. After taking pressure readings, be sure to turn screws clockwise firmly to reseal. DO NOT OVER TORQUE. Leak test with a soap and water solution.
		 <p style="text-align: center;">PILOT SCREW</p>
	Air shutter improperly adjusted.	- Return air shutter to specified opening, see “venturi adjustments” section in the installation manual.
Carbon is being deposited on glass, logs, rocks, media, or combustion chamber surfaces.	Air shutter is blocked. Flame is impinging on the glass, logs, rocks, media or combustion chamber.	- Ensure air shutter opening is free of lint or other obstructions. - Ensure the media is positioned correctly in the appliance. - Open air shutter to increase the primary air. - Check the input rate: check the manifold pressure and orifice size as specified by the rating plate. - Ensure door gaskets are not broken or missing and the seal is tight. - Ensure vent liners are free of holes and well sealed at all joints. - Check that minimum rise per foot (meters) has been adhered to for any horizontal venting.
White / grey film forms.	Sulphur from fuel is being deposited on glass, logs, or combustion chamber surfaces.	- Clean the glass with a recommended gas fireplace glass cleaner. DO NOT CLEAN GLASS WHEN HOT. - If deposits are not cleaned off regularly, the glass may become permanently marked.
Exhaust fumes smelled in room, headaches. (This is not applicable in outdoor appliances).	Appliance is spilling. (This is not applicable in outdoor appliances).	- Check door seal. - Check for exhaust damage. - Check that venting is installed correctly. - Room is in negative pressure; increase fresh air supply.

symptom	problem	test solution
Pilot will not light. Makes noise with no spark at pilot burner.	Wiring: short, loose, or damaged connections (poor flame rectification).	<ul style="list-style-type: none"> - Verify the thermocouple/sensor is clean and the wiring is undamaged. - Verify the interrupter block is not damaged or too tight. Verify connections from pilot assembly are tight; also verify the connections are not grounding out to any metal. (Remember, the flame carries the rectification current, not the gas. If flame lifts from pilot hood, the circuit is broken. A wrong orifice or too high of an inlet pressure can cause the pilot flame to lift)*. The sensor rod may need cleaning.
	No signal from remote with no pilot ignition.	<ul style="list-style-type: none"> - Reprogram receiver code. - Replace receiver.
	Poor grounding.	<ul style="list-style-type: none"> - Verify the valve / pilot assembly are properly grounded
	Improper switch wiring.	<ul style="list-style-type: none"> - Troubleshoot the system with the simplest on/off switch.
	Dirty, painted, or damaged pilot and/or dirty sensor rod.	<ul style="list-style-type: none"> - Clean sensor rod with a green Scotch-Brite™ pad to remove any contamination that may have accumulated. Verify continuity with multimeter with ohms set at the lowest range.
Pilot sparks but will not light.	Gas supply.	<ul style="list-style-type: none"> - Verify that the incoming gas line ball valve is “open”. - Verify that the inlet pressure reading is within acceptable limits, inlet pressures must not exceed 13” W.C. (32.4mb).
	Out of propane gas.	<ul style="list-style-type: none"> - Fill the tank.
	Pilot supply line may contain air.	<ul style="list-style-type: none"> - Repeat ignition process several times or purge the pilot supply line.
	Incorrect wiring / grounding.	<ul style="list-style-type: none"> - Ensure correct polarity of wiring of thermocouple (if equipped). - Verify pilot assembly / valve are properly grounded.
	Receiver (if equipped).	<ul style="list-style-type: none"> - Reset program: hold reset button on receiver and wait for 2 beeps. Release after second beep. Press small flame button on remote within 20 seconds, you will hear an additional beep (this signals a successful reset). - Replace receiver.
	Valve.	<ul style="list-style-type: none"> - Check valve and replace if necessary (Do not to overtighten thermocouple).
Burner continues to spark and pilot lights but main burner does not light.	Short or loose connection in sensor rod.	<ul style="list-style-type: none"> - Verify all connections. Verify the connections from the pilot assembly are tight. Also, verify these connections are not grounding out to any metal.
	Dirty, painted, or damaged pilot assembly components.	<ul style="list-style-type: none"> - Clean using a green Scotch-Brite™ pad to remove any contamination that may have accumulated on the sensor rod, pilot hood, ignitor, or flame sensor. Verify continuity with multimeter with ohms set at the lowest range.
Remote wall switch is in “ off ” position; burner comes on.	Wall switch mounted upside down.	<ul style="list-style-type: none"> - Reverse.
	Remote wall switch and/or wire is grounding.	<ul style="list-style-type: none"> - Replace. - Check for ground (short); repair ground or replace wire.
	Faulty wire	<ul style="list-style-type: none"> - Replace.
Remote and / or receiver is not functioning properly.	Remote controls lights but no spark or flame. (Remote is locked out).	<ul style="list-style-type: none"> - Reset by turning power source off then on. <div style="border: 1px solid black; padding: 5px; margin-top: 5px;"> <p>note: If back up batteries are installed, they must also be removed to re-program</p> </div>
	Receiver or remote has low battery.	<ul style="list-style-type: none"> - Replace batteries.
	Appliance functions but does not respond to receiver / remote	<ul style="list-style-type: none"> - Ensure appliance is being operated by the same device that turned it on. Remote controls function if appliance was turned on by remote. Receiver controls function if appliance was turned on by receiver.
	Error with synchronizing.	<ul style="list-style-type: none"> - Reset receiver and remote.
	Remote too far away from receiver.	<ul style="list-style-type: none"> - Refer to “wiring diagram” section.
	Wire connector pins are bent.	<ul style="list-style-type: none"> - Straighten pins.
	Valve wiring is damaged.	<ul style="list-style-type: none"> - Replace valve.

symptom	problem	test solution
Lights or blower won't function (if equipped).	Control module switch in wrong position.	- Verify ON/OFF switch is in the "I" position which denotes on.
	COM switch is unplugged.	- Verify "COM" switch is plugged into the front of the control module.
Flames are very aggressive.	Door is ajar.	- Ensure door is secured properly.
	Venting action is too great.	- Check to ensure venting is properly sealed or restrict vent exit with restrictor plate. (Not available in all appliances).
Appliance won't perform any functions.	No power to the system.	- Check breaker to verify it's in the "on" position.
	Receiver switch in wrong position (if equipped).	- Verify that the 3 position switch on the receiver is in the remote position (middle).
	Transmitter isn't operational.	- Check battery power and battery orientation.

symptom	problem	test solution
---------	---------	---------------

The following applies specifically to the SIT system only:

Pilot will not light. Makes no noise with no spark at pilot burner. (Lights and blower operate, if equipped).	Ignition box has been locked out.	<p>Choose one of the 3 methods below to reset the system.</p> <ol style="list-style-type: none"> To reset ignition box when locked out. Turn off power supply and remove batteries (if used) from the back up battery pack. To reset the DFC Board when the board goes into a lock out condition and the LED is blinking 3 times using the transmitter on/off button: <ul style="list-style-type: none"> Step 1: Turn the system off by pressing the on/off button to turn the system off. Step 2: After approximately 2 seconds press the on/off button on the transmitter again. The DFC Board will reset and the ignition sequence will start again. To reset the DFC Board when the board goes into a lock out condition and the LED is blinking 3 times by cycling flame: <ul style="list-style-type: none"> Step 1: In the manual flame control mode, use the down arrow button to reduce the flame to off, indicated by the word OFF displayed on the transmitter LCD screen. Step 2: Wait approximately 2 seconds and press the up arrow button, the ignition sequence will start.
---	-----------------------------------	--

note:

Starting from **off**, press the **on** button on the transmitter. After approximately 4 seconds **on/off** button is pressed, the ignition board will start the spark. The attempt for ignition will last approximately 60 seconds. If there is no flame ignition (rectification), the board will stop sparking and the board will go into lock out.

Napoleon products are manufactured under the strict Standard of the world recognized ISO 9001 : 2015 Quality Management System.

Napoleon products are designed with superior components and materials assembled by trained craftsmen who take great pride in their work. The burner and valve assembly are leak and test-fired at a quality test station. The complete appliance is again thoroughly inspected by a qualified technician before packaging to ensure that you, the customer, receive the quality product that you expect from Napoleon.

Napoleon Gas Appliance President's Lifetime Limited Warranty

The following materials and workmanship in your new Napoleon gas appliance are warranted against defects for as long as you own the appliance. This covers: combustion chamber, heat exchanger, stainless / steel burner, Phazer™ logs and embers, rocks, ceramic glass (thermal breakage only), gold plated parts against tarnishing, porcelainized enameled components and aluminum extrusion trims.*

Electrical (110V and millivolt) components and wearable parts are covered and Napoleon will provide replacement parts free of charge during the first year of the limited warranty. This covers: blowers, gas valves, thermal switches, switches, wiring, remote controls, ignitors, gaskets and pilot assemblies.*

Labour related to warranty repair is covered free of charge during the first year (labour warranty is not applicable for the Gas Log Sets). Repair work, however, requires the prior approval of an authorized company official. Labour costs to the account of Napoleon are based on a predetermined rate schedule and any repair work must be done through an authorized Napoleon dealer.

* Construction of models vary. Warranty applies only to components included with your specific appliance.

Conditions and Limitations

Napoleon warrants its products against manufacturing defects to the original purchaser only. Registering your warranty is not necessary. Simply provide your proof of purchase along with the model and serial number to make a warranty claim. Napoleon reserves the right to have its representative inspect any product or part thereof prior to honouring any warranty claim. Provided that the purchase was made through an authorized Napoleon dealer your appliance is subject to the following conditions and limitations:

Warranty coverage begins on the date of original installation. This factory warranty is non-transferable and may not be extended whatsoever by any of our representatives. The gas appliance must be installed by a licensed, authorized service technician or contractor qualified and authorized installer, service agency or supplier. Installation must be done in accordance with the installation instructions included with the product and all local and national building and fire codes. This limited warranty does not cover damages caused by misuse, lack of maintenance, accident, alterations, abuse or neglect, and parts installed from other manufacturers will nullify this warranty. This limited warranty further does not cover any scratches, dents, corrosion or discoloring caused by excessive heat, abrasive and chemical cleaners nor chipping on porcelain enamel parts, mechanical breakage of Phazer™ logs and embers. This warranty extends to the repair or replacement of warranted parts which are defective in material or workmanship provided that the product has been operated in accordance with the operation instructions and under normal conditions. After the first year, with respect to this President's Lifetime Limited Warranty, Napoleon may, at its discretion, fully discharge all obligations with respect to this warranty by refunding to the original warranted purchaser the wholesale price of any warranted but defective part(s).

After the first year, Napoleon will not be responsible for installation, labour, or any other expenses related to the reinstallation of a warranted part and such expenses are not covered by this warranty. Notwithstanding any provisions contained in the President's Lifetime Limited Warranty, Napoleon's responsibility under this warranty is defined as above and it shall not in any event extend to any incidental, consequential or indirect damages. This warranty defines the obligations and liability of Napoleon with respect to the Napoleon gas appliance and any other warranties expressed or implied with respect to this product, its components or accessories are excluded. Napoleon neither assumes, nor authorizes any third party to assume, on its behalf, any other liabilities with respect to the sale of this product. Napoleon will not be responsible for: over-firing, downdrafts, spillage caused by environmental conditions such as rooftops, buildings, nearby trees, hills, mountains, inadequate vents or ventilation, excessive venting configurations, insufficient makeup air, or negative air pressures which may or may not be caused by mechanical systems such as exhaust fans, furnaces, clothes dryers, etc. Any damages to the appliance, combustion chamber, heat exchanger, plated trim or other components due to water, weather damage, long periods of dampness, condensation, damaging chemicals or cleaners will not be the responsibility of Napoleon.

During the first 10 years Napoleon will replace or repair the defective parts covered by the lifetime warranty at our discretion free of charge. From 10 years to life, Napoleon will provide replacement parts at 50% of the current retail price. The manufacturer may require that defective parts or products be returned or that digital pictures be provided to support the claim. Returned products are to be shipped prepaid to the manufacturer for investigation. If a product is found to be defective, the manufacturer will repair or replace such defect. Before shipping your appliance or defective components, your dealer must obtain an authorization number. Any merchandise shipped without authorization will be refused and returned to sender. Shipping costs are not covered under this warranty. Additional service fees may apply if you are seeking warranty service from a dealer. Warranty labour allowance is only for the replacement of the warranted part. Travel, diagnostic tests, shipping and other related charges are not covered by this warranty.

NAPOLEON CELEBRATING OVER 40 YEARS OF HOME COMFORT PRODUCTS



7200, Route Transcanadienne, Montréal, Québec H4T 1A3
24 Napoleon Road, Barrie, Ontario, Canada L4M 0G8
214 Bayview Drive, Barrie, Ontario, Canada L4N 4Y8
103 Miller Drive, Crittenden, Kentucky, USA 41030
De Riemsdijk 22, 4004 LC Tiel, The Netherlands

Phone: 1-866-820-8686
napoleon.com